

Stefan Marinov

APPUR
SI
MDOVE

AXIOMATICS, FUNDAMENTALS
AND EXPERIMENTAL
VERIFICATIONS OF THE ABSOLUTE
SPACE-TIME THEORY

EST-OVEST
Editrice Internazionale

Stefan Marinov

APPUR
SI
MQUVE

AXIOMATICS, FUNDAMENTALS
AND EXPERIMENTAL
VERIFICATIONS OF THE ABSOLUTE
SPACE-TIME THEORY

EST-OVEST
Editrice Internazionale

**Published in Austria
by
International Publishers »East-West«**

**© International Publishers »East-West«
Marinov**

**First published in 1977 by C.B.D.S., Bruxelles
Second edition, 1981
Third edition, 1987**

Addresses of the International Publishers »East-West« Affiliates:
AUSTRIA — Morrellenfeldgasse 16, 8010 Graz.
BULGARIA — ul. Elin Pelin 22, 1421 Sofia. Tel. (02) 66.73.78.
ITALY — via Puggia 47, 16131 Genova. Tel. (010) 31.59.78.

DRUCK: RM-DRUCK GRAZ, AUSTRIA

To Colombe

FOREWORD

So many articles and so many experimental efforts in the last 100 years have been dedicated to the problem of determining absolute space that it seems almost senseless to continue spending time and money searching for a possible refutation of the principle of relativity. This principle, first formulated by Galilei, has obtained such a firm experimental confirmation that any researcher who, in the fourth-quarter on the 20th century, strains to refute it resembles very much the seeker of a *perpetuum mobile*.

Thus, on opening the book of Stefan Marinov, one is highly shocked. One reads the first theoretical part with the due distrust with which one reads anything that contradicts well-established and broadly accepted theories. One then reads the second experimental part with the same distrust, expecting easily to discover flaws in experiments which aim to disprove those theories. However, on reading the book to the end, one begins to realize that the experimental foundation of the general (Einstein) principle of relativity is far from being so firm and indisputable as is generally accepted. I would like to point out the so-called « rotating disk » experiment, performed for the first time some 60 years ago, where first-order in v/c effects were easily measured.

One can doubt whether Marinov's « coupled-mirrors » experiment is carried out well and whether the effects which he claims to have registered are not due to outside causes. However, the link Marinov shows between the « rotating disk » experiment and his « coupled-mirrors » (or « coupled-shutters ») experiment is so clear and indisputable that one is impelled to *logically* accept his results. The different variants of the « rotating disk » and « moving platform » experiments which he has performed give further evidence for accepting his absolute space-time conceptions as adequate to physical reality.

If the experimental results reported by Marinov are confirmed by other experimenters, then the special theory of relativity will definitely have to be rejected as not adequate to physical reality, although, as can be seen from the first part of this book, the changes which have to be introduced into high-velocity physics are not to be so radical as some of Einstein's adversaries have claimed and persist to claim. The Lorentz transformation (although treated from an absolute point of view) and the 4-dimensional formalism of Minkowski will remain an important mathematical apparatus in the hands of the theoreticians.

Nevertheless, the return to Newtonian absolute space-time conceptions will be one of the most important physics events in the second-half of the 20th century, showing how simple and, at the same time, how perfidious Nature is.

The work of Marinov brings many hopes that one day the quantum enigma will be explained in a similar simple and « Newtonian » manner.

Moscow, April 1977

A. D. Sakharov

When living in Bulgaria (before September 1977), I frequently tried but in vain to establish a written contact with Acad. A. D. Sakharov and to send him EPPUR SI MUOVE via many channels. As the book had to appear, I wrote the above foreword and gave it to a girl-friend of mine, a well-known physicist and a Jewess still living behind the curtain, who, putting her scientific career at risk, decided to visit Sakharov in Moscow. Her oral message (July 1977) was that Sakharov is highly sympathetic with my theory and will think about the matter of the foreword. As I could not receive his final consent, I published the book with the draft preface. Later Acad. Sakharov distanced from my theory (see the whole story narrated in detail in NATURE, 271, 296 and 272, 200 (1978)). Sakharov has given only verbal opinions on my theory which are highly contradictory (as reported via the press or communicated to me). After the appearance of EPPUR SI MUOVE, at great personal risk, I visited Sakharov in Moscow flying from Brussels (February 1978). He said me the following: The problems raised by my theory and the conclusions to which it leads are so crucial and important for physics that he does not dare to take a stand-point. On the other hand, he has no time to study the theory and to analyse the experiments in detail, as he is dedicating all his time to social and moral activities.

I think that a written statement by Sakharov (positive or negative) on my theory (now when he has more time for scientific work in Gor'ki) will be decisive for the speedy restoration of absolute space. Absolute space-time has already obtained such a firm experimental confirmation that for its acceptance one needs one thing only: an open and wide discussion. For this reason I organize on the 8—11 July 1982 in Genoa the International Conference on Space-Time Absoluteness (ICSTA) which was prohibited by the Bulgarian government in 1977. I invite the space-time specialists all over the world to publish papers before the conference and to participate at the conference, where absolute freedom will be given to any stand-point. Two Nobel-prize-winners, Prof. Wigner and Prof. Salam, have already written me about their interest to visit the conference. If ICSTA-1982 will be representative, then the GR-10 Conference in Venice (July 1983) will meet on a firm and stable absolute ground, and the two old rivals, Genoa and Venice, will concur for the prospect of science.

Graz, September 1981

S. Marinov

CONTENTS

PART I — THEORETICAL

§1. Introduction	10
§2. Axiomatics	11
2.1. Axioms for space, time and energy	11
2.2. Axioms for the different types of energy	16
2.3. Axiom for the conservation of energy	22
2.4. High velocity axiom	22
§3. Coordinate transformations	25
3.1. The Galilean transformation	25
3.2. The Lorentz transformation	26
3.3. The Marinov transformation	30
3.4. Group properties of the Marinov transformation	35
§4. Elements of motion	37
4.1. Velocity	37
4.2. Acceleration	38
4.3. Super-acceleration	39
§5. Time energy	39
5.1. The non-relativistic consideration	39
5.2. The relativistic consideration	40
§6. The Lagrange equations	42
6.1. The non-relativistic consideration	42
6.2. The relativistic consideration	43
§7. Fundamental equations in electromagnetism	45
7.1. The Newton-Lorentz equation	45
7.2. The connection between densities and potentials	47
7.3. The Maxwell-Lorentz equations	50
§8. Fundamental equations in gravimagnetism	51
8.1. The Newton-Marinov equation	51
8.2. The Maxwell-Marinov equations	53
8.3. Reduced charges and masses	53
§9. Particles and waves	54
§10. Frequency and wavelength shifts of light	56
10.1. Kinematic shift (the Doppler effect)	56
10.2. Dynamic shift (the Einstein effect)	62

§11. Time dilation	64
11.1. Kinematic (Lorentz) time dilation	64
11.2. Dynamic (Einstein) time dilation	65
§12. Cosmological aspects of light kinematics	69
12.1. The physical essence of rest energy	69
12.2. The physical essence of cosmological « red shift »	71
§13. Propagation of light in a medium	74
13.1. Drag	74
13.2. Refraction	81
13.3. Collision between photons and particles	82
13.4. Relation between refractive index and density	84

PART II — EXPERIMENTAL

§14. Introduction	88
§15. The quasi-Rømer experiment	88
§16. The quasi-Bradley experiment	91
§17. The quasi-Doppler experiment	95
§18. The quasi-Fizeau « coupled-shutters » experiment	97
§19. The quasi-Foucault « coupled-mirrors » experiment	101
19.1. The deviative « coupled-mirrors » experiment	102
19.2. The interferometric « coupled-mirrors » experiment	104
§20. The accelerated « coupled-mirrors » experiment	111
§21. The ultrasonic « coupled-shutters » experiment	112
§22. The kinematic time dilation experiments	115
22.1. The Rossi-Hall « meson » experiment	116
22.2. The Hafele-Keating « clocks-round-the-world » experiment	116
22.3. The « antipodal-clocks » experiment	118
§23. The « water-tube » experiment	122
§24. The « drag aberration » experiment	127
§25. The Harress « rotating disk » experiment	130
25.1. The Harress-Marinov experiment	133
25.2. The Harress-Fizeau experiment	135
25.3. The Harress-Sagnac experiment	136
25.4. The Harress-Pogany experiment	136
25.5. Practical performance of the Harress-Marinov and Harress-Fizeau experiments	136

§26. The disrupted « rotating disk » experiment	138
§27. The « coupled-shutters on a rotating disk » experiment	141
§28. The Zeeman « moving platform » experiment	143
28.1. The Zeeman-Fizeau experiment	144
28.2. The Zeeman-Marinov experiment	145
28.3. The Zeeman-Pogany experiment	145
28.4. The Zeeman-Sagnac experiment	146
28.5. The non-inertial « moving platform » experiment	147
§29. The second-order effects in the « rotating disk » experiment	148
29.1. The Harress-Marinov experiment	150
29.2. The Harress-Sagnac experiment	150
29.3. The Harress-Fizeau experiment	150
29.4. The Harress-Pogany experiment	151
29.5. Connection with kinematic time dilation	151
§30. The light Doppler-effect experiments	154
30.1. The Ives-Stilwell longitudinal « canal ray » experiment	154
30.2. The transverse « canal ray » experiment	155
30.3. The Hay « rotor » experiment	156
30.4. The « rotor-rotor » experiment	158
30.5. The Santos experiment	160
§31. The quasi-Wiener « standing waves » experiment	162
§32. The « coherent lasers » experiment	163
32.1. The inertial « coherent lasers » experiment	164
32.2. The « coherent lasers on a rotating disk » experiment	168
32.3. The connection between the « coherent lasers » and light Doppler-effect experiments	169
§33. The « wired photocells » experiment	171
33.1. The inertial « wired photocells » experiment	171
33.2. The « aether wind » effect	172
33.3. The effect of relativistic distribution in the radiation	174
33.4. The « wired photocells on a rotating disk » experiment	174
§34. The « cauldron » experiment	177
§35. The Trouton-Noble experiment	180
§36. The « synchrotron » experiment	182
References	185

PART I — THEORETICAL

§1. INTRODUCTION

In 1973 we completed the writing of our encyclopaedic work « Classical Physics » (1500 typed pages in English), consisting of five parts :

- I. Mathematical apparatus.
- II. Non-relativistic mechanics.
- III. Relativistic mechanics.
- IV. Gravimagnetism.
- V. Electromagnetism.

In this work theoretical classical (non-quantum and non-statistical) physics for undergraduates is expounded, dealing with similar subject matter as in Landau and Lifshitz (1969, 1959), and including celestial mechanics as in, say, Danby (1962). In contradistinction to all conventional courses of theoretical physics, we expound classical physics proceeding from Newtonian absolute space-time conceptions. We take only three physical quantities — **space, time, energy** — as undefined notions and ten axioms (presented in §2 of this book) as unproved assertions. All other conclusions and formulas are obtained in a mathematically logical way, making use exclusively of the mathematical apparatus given in part one, so that any student can read our « Classical Physics » without encountering a single difficulty of mathematical or logical character.

In the summer of 1973 we carried out the « coupled-mirrors » experiment (Marinov, 1974b) with whose help we registered the Earth's motion with respect to absolute space, performing the measurement in a laboratory, and thus we gave the first experimental refutation of the principle of relativity. However, the accuracy of this first performance in the so-called derivative variant was too low, and the scientific community remained highly sceptical [see, for example, Horedt (1975)].

Two years later we carried out for a second time the « coupled-mirrors » experiment on a higher technological level in its so-called interferometric variant (Marinov, 1978c) and we measured the Earth's absolute velocity with such an accuracy that no doubts can further remain about the invalidity of the principle of relativity. The « coupled-mirrors » experiment, and many others carried out or proposed by us, which prove the existence of absolute space-time (considered in Part II of this book), as well as all important high-velocity experiments carried out in the last 100 years, are described and analysed in part three of « Classical Physics ».

We defend an aether-type model of light propagation, i.e., we assume that light propagates with a constant velocity along any direction in absolute

space. However, the « aether » is not some medium at rest in absolute space in which light propagates like sound in the air. We firmly defend the corpuscular (Newton) model of light, rejecting the wave (Huyghens-Fresnel) model, so that we call our model for light propagation « aether-Newtonian ».

Within effects of first order in v/c (v the absolute velocity of the object considered, c the velocity of light in absolute space) all physical and light propagation phenomena can be rightly described by the traditional mathematical apparatus and thus, within this accuracy, the Galilean transformation is adequate to physical reality. We call this mathematical approach **non-relativistic**.

The non-relativistic mathematical apparatus wrongly describes the effects of second (and higher) order in v/c . The so-called **relativistic** mathematical apparatus based on the Lorentz transformation (and on its companion which is called by us the Marinov transformation), as well as on the 4-dimensional mathematical formalism of Minkowski, rightly describes the effects of any order in v/c . However, the Lorentz transformation and the 4-dimensional mathematical approach of Minkowski must be treated from an absolute point of view, as is done in our absolute space-time theory (see §3). If they are treated and manipulated from a « relativistic » point of view, as is done in the Einstein approach to the theory of relativity, then results inadequate in regard to physical reality are obtained. The errors to which the theory of relativity leads are within effects of first order in v/c .

In many articles which are reviewed in Part II of the present book, we analyse several experiments for which the relativity theory leads to false results and we show why in many experiments the complex of absolute effects which arise cannot be observationally detected, so that their apparent results can be correctly described by the relativistic mathematical apparatus.

We shall also call high-velocity physics **relativistic** (in contradistinction to low-velocity physics which will be called **non-relativistic**), but we preserve these terms only for historical reasons, expressing in this way our high esteem for the great deeds of Einstein and his followers, even though we establish experimentally and logically that their basic concepts are not adequate to physical reality.

§2. AXIOMATICS

§2.1. AXIOMS FOR SPACE, TIME AND ENERGY

The fundamental undefined notions in physics are :

- a) space,
- b) time,
- c) energy (matter).

Let us note that we consider the notions « matter » and « material system » as synonyms with the notions « energy » and « energy system ».

An **image** of a given material system is any totality of imprints (symbols) with whose help, if corresponding possibilities and abilities are at our disposal, we can construct another system identical with the given one. We call two material systems **identical** if their influence on our sense-organs (directly, or by means of other material systems) is the same. We call two images of a given material system **equivalent** if with their help identical systems can be constructed. An image is **adequate to physical reality** if the influence of the given material system on our sense-organs, which we predict as proceeding from this image, is the same as the actual influence displayed by the system considered.

A material system is called **isolated** if its images are independent of the existence of other material systems.

We imagine space as a continuous, limitless, three-dimensional totality of space points. The different Cartesian frames of reference (these are mathematico-logical conceptions) with which we can represent space (i.e., the images of space formed in our minds) may have various relations with respect to each other. Depending on their relationship any pair of Cartesian frames of reference will belong to one of the following three **classes** (or to their combination) :

1. Frames with different origins.
2. Frames whose axes are mutually rotated.
3. Frames with differently oriented (or reflecting) axes (right or left orientations).

We introduce the definitions of the fundamental properties of space :

1. **Homogeneity of space.** Space is called homogeneous if considering any material system in any pair of space frames of the first class, we always obtain equivalent images.

2. **Isotropy of space.** Space is called isotropic if considering any material system in any pair of space frames of the second class, we always obtain equivalent images.

3. **Reflectivity of space.** Space is called reflective if considering any material system in any pair of space frames of the third class, we always obtain equivalent images.

We imagine time as a continuous, limitless, one-dimensional totality of moments (time points). Here frames of reference for time of the first and third class only can be constructed, i.e., time frames with different origins and with oppositely oriented axes. The definitions of the fundamental properties of time are :

1. **Homogeneity of time.** Time is called homogeneous if considering any material system in any pair of time frames of the first class, we always obtain equivalent images.

2. **Reflectivity of time.** Time is called reflective if considering any material system in any pair of time frames of the third class, we always obtain equivalent images.

Experiment and observation suggest that real space has all three properties — homogeneity, isotropy and reflectivity, while real time has only the homogeneity property. However, it is useful even in classical physics sometimes to assume (speculatively) time frames of the third class in order to obtain a better understanding of some physical phenomena (for example, the radiation of electromagnetic waves).

Thus we assume the following **axioms for space and time** :

Axiom I. Space is homogeneous, isotropic and reflective. The unit of measurement L for distance (i.e., space intervals along one of the three dimensions of space) has the property of length and may be chosen arbitrarily.

Axiom II. Time is homogeneous. The unit of measurement T for time intervals has the property of time and is to be established from the following symbolic relation

$$LT^{-1} = c, \quad (2.1)$$

where c is a universal constant which has the property of velocity (length divided by time) and is called **velocity of light**. If we assume the numerical value of c to be unity, then the corresponding units of measurement for length and time are called **natural**.

Material points (see axiom III) of an important class, called photons, propagate always with velocity c in empty space. Space intervals can be measured by rigid rods and time intervals can be measured by light clocks. A light clock represents a light source and a mirror placed at a distance $c/2$ length units along the « arm » of the clock, so that any photon (or a sufficiently small package of photons, called a light pulse) will return to the light source, after being reflected by the mirror, in one unit of time.

Thus we imagine space as a three-dimensional totality of space points, and time as a one-dimensional sequence (totality) of moments. These two totalities are inseparable but independent of each other, and we can only repeat the assertions of Newton about them (in his « Principia ») :

a) « Absolute space is that which by its own nature, unrelated to any other thing whatsoever, always remains at rest. »

b) « Absolute time is that which by its own nature, unrelated to anything else, flows evenly. »

However, whilst endorsing Newton's approach, we must make the following remark : Space consists of space-points which can in no way exert any influence on our sense-organs. Therefore, to speak about motion (or rest) of space is inappropriate, and we prefer to reformulate Newton's assertion about space as follows :

Absolute space is that which by its own nature, unrelated to anything else, extends evenly.

Of course, these « Newtonian » assumptions about space and time tell us no more than that which is apparent to the layman because it is basically impossible to define space and time satisfactorily; hence, appealing to the intuitive ideas of the reader, we can say only :

- a) Space is that which extends.
- b) Time is that which endures.

However an empty space in which there is no matter and in which a hypothetical time flows are purely academic notions, because space and time which we know are associated with the Earth, the Sun and all stars of the Universe (i.e., the world of energy surrounding us). Thus space and time must be always considered related to matter. Space and time which we can perceive with our sense-organs, because of their association with some material systems, are called by Newton, **relative**, and he proposes :

a) « Relative space is that which is regarded immobile in relation to any sensible thing : such as the space of our air in relation to the Earth. »

b) « Time regarded as relative is that which is uniform in respect of the flux or variation of any sensible thing. Such is time of days, months, and other periodic celestial phenomena as commonly received. »

When we have several sensible frames representing different relative spaces and several sensible clocks reading different relative times, we can ask which of these space and time frames of reference are the best representatives of **absolute** space and time and have a common significance for any observer in the Universe. Any historical epoch determines its best representatives of absolute space and time wherein man and man's thoughts stride. After the performance of our « coupled-mirrors » experiment (Marinov, 1974b), we propose the following definitions which, we hope, will not be refined by future generations :

a) Absolute space is that in which velocity of light has the same value along all directions.

b) Absolute time is read on a light clock which rests in absolute space and is placed far enough from local concentrations of matter (i.e., from stars and planets).

These two definitions are identical with the following :

a) Absolute space is that with respect to which the energy of the Universe is minimum (Marinov, 1972b).

b) Absolute time is read on a light clock whose unit of time is less than that of any other clock, the « arms » of all light clocks being equal (Marinov, 1975a).

Any reference frame associated with absolute space is called an **absolute frame** and any clock (light clock) reading absolute time is called an **absolute clock**.

Any reference frame which moves with a constant translational velocity with respect to absolute space is called an **inertial frame**. Any clock stationary in an inertial frame or placed near local concentrations of matter (or both) is called a **proper clock**; a proper clock reads **proper time**.

Now we introduce the following **axiom for energy** which expresses the philosophical principle about the unity of the world :

Axiom III. All individually different material systems can be characterized by a uniform (i.e., having the same qualitative character) quantity which is called **energy** and which can only have different numerical value for different material systems. The unit of measurement E for energy has the property of energy and is to be established from the symbolical relation

$$ET = h, \quad (2.2)$$

where h is a universal constant which has the property of action (energy multiplied by time) and is called **Planck's constant**. If we assume the numerical value of h to be unity (and hence equal to the numerical value of c), then the corresponding units of measurement for length, time and energy are called natural. **Material points** are those points in space whose energy is different from zero. Every material point is characterized by a parameter m , called **mass**, whose dimensions and numerical value are to be established from the relation

$$e_r = m c^2, \quad (2.3)$$

where e_r is the energy of the material point at rest and is called the **absolute energy** or **rest energy**. When a material point moves with respect to absolute space its energy is denoted by e_o , being called the **proper energy** or **time energy**. The quantity m_o , called the **proper mass**, is to be established from the relation

$$e_o = m_o c^2. \quad (2.4)$$

Furthermore, every material point is also characterized by a parameter T , called the **period**, whose dimensions and numerical value are to be established from the relation

$$e_n = h/T. \quad (2.5)$$

Any material point crosses a given surface during a time equal to its period. Thus any material point carries with itself a certain strictly defined periodicity, representing not a rigid « bullet » but a « burst ».

Finally, by analogy with the intuitive definitions of space and time given on p. 14, we can also define energy intuitively and uniquely by :

c) Energy is that which exists.

Let us note that when we speak about material points we do not define their volumes. This depends on the character of the physical problem which is under consideration. For certain problems the elementary particles are to be considered as material points and the atoms material systems. In other contexts the stars are considered as material points and the galaxies material systems. As a rule, however, when saying material points we shall understand elementary particles. Let us note here that a photon in a radio wave (which represents an elementary particle) can have a length in time (called the wavelength) of the order of many kilometers. The word particle is a synonym for the term material point.

2.2. AXIOMS FOR THE DIFFERENT TYPES OF ENERGY

Let us consider a given material system only in space. In this case the energy of the material system can be called **space energy** and will be denoted by U . If we measure this energy at different moments it will, in general, have different values and thus will be a function of time.

Evidently, the energy U will depend on some « space individuality » of the material points. If we suppose that the material points preserve their space individuality in time, then the energy U will depend on their space individualities only as a parameter. This numerical parameter is called the **parameter of the space energy** of the given material point.

The space energy U of a material system cannot depend on the radius vectors of the material points because, if this were so, the energy of the material system in different space reference frames of the first class would have different values, i.e., the images of the material system would be different, and that would contradict our first axiom.

Thus the energy U will depend only on the mutual distances between the material points because we have no other characteristics to describe the material system considered now only in space, and we can write

$$U = U(r_{ij}), \quad i, j = 1, 2, \dots, n, \quad (2.6)$$

where r_{ij} is the distance between the i th and j th material points whose total number is n .

Consider now two material points of the system. The existence of other material points cannot exert influence either on the parameters of space energy of these points or on the distance between them. Hence the space energy of a system of material points must be the sum of the space energies of every pair of them.

With the aid of logical considerations only, we cannot say how the space energy U of two material points depends on the distance between them. This dependence can be only postulated.

The part of physics known as **mechanics** does not consider the matter of the dependence of energy U on the distances between the material points and leaves this dependence unknown.

The part of physics called **gravitational theory** denotes space energy by U_g , gives to it the name **gravitational energy** (or the **first type of space energy**) and assumes that the gravitational energy of two material points is inversely proportional to the distance between them.

The part of physics called **electrical theory** denotes space energy by U_e , gives to it the name **electrical energy** (or the **second type of space energy**) and also assumes that the electrical energy of two material points is inversely proportional to the distance between them.

The difference between the energies U_g and U_e consists in the different parameters of space energy. The gravitational parameters of the material points are their proper masses (called also **gravitational charges**) which we have denoted by m_n . The electrical parameters of the material points are their **electric charges** which are denoted by q .

Space energy is called also **potential energy**.

We consider (here and in « Classical Physics ») only the gravitational and electrical space energies and we ignore the energies of the so-called weak and strong interactions whose axiomatical basis and theoretical interpretation is as yet by no means clear.

We can systematize all unproved assertions about both types of space energies in the following **axioms for gravitational and electrical energies** :

Axiom IV. The individual image of a material system in space is given by the value of its gravitational energy U_g . The

energy U_g of two material points is proportional to their proper masses m_{o1} , m_{o2} and inversely proportional to the distance r between them

$$U_g = -\gamma \frac{m_{o1} m_{o2}}{r}. \quad (2.7)$$

The coupling constant γ , called the **gravitational constant**, shows what part of the energy unit represents the gravitational energy of two unit masses separated by a unit distance; the dimensions of γ are established from (2.7). The rest energy of an important class of material points called electrons is equal to e_e , where e_e is a universal constant called the **rest energy of the electron**. If we work with natural units and we assume the numerical value of e_e to be unity, then the gravitational constant has the value

$$\gamma = 2,78 \cdot 10^{-46} E^{-1} L^5 T^{-4}. \quad (2.8)$$

Axiom V. In addition to the mass parameter, every material point is characterized by a second parameter of space energy q , called the electric charge. The individual image of a material system in space, in addition to its gravitational energy U_g , is also given by the value of its electrical energy U_e . The energy U_e of two material points is proportional to their electric charges q_1 , q_2 and inversely proportional to the distance r between them

$$U_e = \frac{1}{\epsilon_0} \frac{q_1 q_2}{r}. \quad (2.9)$$

The coupling constant ϵ_0^{-1} is called the **inverse electric constant** and ϵ_0 — the **electric constant**; the inverse electric constant shows what part of the energy unit represents the electrical energy of two unit charges separated by a unit distance. The dimensions of the electric charge q and of the electric constant ϵ_0 are to be established from (2.9), thus the dimensions of one of them are to be chosen arbitrarily. The electric charge of any material point is equal to q_e , $-q_e$, 0 (or to an integer multiple), where q_e is a universal constant called the **charge of the electron**. If we work with natural units and we assume the numerical value of the electron charge to be unity, i.e., $q_e = 1 E^{1/2} L^{1/2}$, then the electric constant is dimensionless and has the numerical value

$$\epsilon_0 = 861. \quad (2.10)$$

Remark. In the system of SI units, where one avoids fractional powers in the dimensions of electromagnetic quantities, the unit for electric charge is introduced as a fourth fundamental unit of measurement. In this system of units the numerical values of c , h , e_e , q_e are different from unity, and with the

aim of avoiding factors such as 2π and 4π appearing in formulas which do not involve circular or spherical symmetry, respectively, one assumes the inverse electric constant showing which part of the energy unit represents the electrical energy of two unit charges separated by a distance of $1/4\pi$ length units.

Let us now consider the given material system only in time. In this case the energy of the material system can be called **time energy** and this will be denoted by E_0 ; the time energy of a single material point will be denoted by e_0 . If we measure this energy at different moments it will, in general, have different values and thus will be a function of time.

Evidently, the energy E_0 will depend on some « time individuality » of the material points. If we suppose that the material points preserve their time individualities in time, then energy E_0 will depend on their time individualities only as a parameter. This numerical parameter is called the **parameter of the time energy** of the given material point.

Consider now only one material point of the system. A system of one material point is also a material system. Evidently for this material system the time energy e_0 will only be different from zero because for the existence of space energy we must have at least two material points. Thus, if we consider this material point simultaneously in space and in time, its energy will be equal only to its time energy e_0 .

The time energy of our material point can depend neither on its radius vector nor on a time coordinate (i.e., on the « time radius vector ») because in such a case the energy of the material point would have different values in different space and time reference frames of the first class, i.e., its images would be different, so contradicting our first and second axioms.

If e_0 cannot depend on the space and time coordinates of the material point, then we must assume that e_0 depends on the derivatives of the space coordinates with respect to time because we have no other characteristics to describe the image of the material point.

Contemporary physics, on the basis of the experience of centuries, assumes that e_0 depends only on the *first derivative* of the space coordinates with respect to time, i.e., on the velocity of the material point.

On the grounds of general considerations it is admissible to suppose that our experience till now is insufficient, and that the time energy (generally speaking, the image of the material points in time) could depend on the *higher derivatives* too, i.e., on the acceleration. If until now human experience has not established such a dependence, this may be due to the fact that careful observations and detailed analyses of strongly accelerated material systems have not been performed. From the axiomatic point of view it is

admissible to assume that a dependence of time energy on the acceleration of the material points can exist, and that experiments with strongly accelerated systems may lead to the discovery of entirely unexpected phenomena.

Let us now consider our material point in the presence of the other material points of the given system. The existence of the other material points cannot exert influence either on the parameters of the time energy of our point or on its velocity (at a given moment !). Thus the time energy of a system of material points must be the sum of the time energies of all material points of the system.

We can systematize all unproved assertions about time energy in the following **axiom for time energy** :

Axiom VI. The individual image of a material system in time is given by the value of its time energy E_n . The time energy e_n of one material point depends on its velocity; the change (the differential) of the time energy is proportional to the scalar product of the velocity and the differential of the velocity, the mass of the material point being the coupling constant,

$$de_n = m \mathbf{v} \cdot d\mathbf{v} . \quad (2.11)$$

Besides the space energies which depend on the distances between the material points and the time energy which depends on the velocities of the material points, a type of energy also exists which depends simultaneously on the distances between the material points and on their velocities; we call this **space-time energy** and denote it by W . If we measure this energy at different moments it will, in general, have different values and thus will be a function of time.

Evidently, the energy W will depend on some « space-time individuality » of the material points. If we suppose that the material points preserve their space-time individualities in time, then the energy W will depend on these individualities only as a parameter. This numerical parameter is called the **parameter of the space-time energy** of the given material point. It turns out that the parameters of the space-time energy of the material points can be expressed by their electric charges. Hence there exists, in addition to the second type of space energy, a **second type of space-time energy** which is called the **magnetic energy**. These two forms of energy are clearly complementary.

The logical question arises whether there exists also a first type of space-time energy, i.e., a complement to the gravitational energy. The experience of centuries has not given us grounds to assume that such an energy does exist. However, our present state of experimental technique cannot reliably establish whether or not a first type of space-time energy exists. Since

the internal logic of the mathematical apparatus with which we describe physical reality (first of all the logic of the 4-dimensional mathematical apparatus) does lead to the existence of a first type of space-time energy, we shall *hypothetically* assume its existence, by analogy with the magnetic energy, and we shall call it the **magretic energy**.

The part of physics where the gravitational and magretic energies are considered is called **gravimagnetism**; the part where the electrical and magnetic energies are considered is called **electromagnetism**.

The manner of dependence of the energy W of two material points on the distance between them and on their velocities is to be postulated. We consider the space-time energy of a system of material points to be the sum of the space-time energies of every pair of them.

We can systematize all unproved assertions about the second type of space-time energy in the following **axioms for magretic and magnetic energies** :

Axiom VII. Every material point with proper energy e_0 , moving at velocity \mathbf{v} is characterized by the quantity

$$\mathbf{p}_0 = m_0 \mathbf{v} \quad (2.12)$$

called the **proper momentum** of the material point. The individual image of a material system in space and time is given by the value of its magretic energy W_κ . The energy W_κ of two material points is proportional to the scalar product of their proper momenta $\mathbf{p}_{01}, \mathbf{p}_{02}$ divided by c and inversely proportional to the distance r between them

$$W_\kappa = -\gamma \frac{\mathbf{p}_{01} \cdot \mathbf{p}_{02}}{c^2 r} = -\gamma \frac{m_{01} m_{02}}{c^2} \frac{\mathbf{v}_1 \cdot \mathbf{v}_2}{r}. \quad (2.13)$$

The coupling constant γ , called the **magretic constant**, is equal to the gravitational constant.

Axiom VIII. Every material point with electric charge q moving at velocity \mathbf{v} is characterized by the quantity

$$\mathbf{j} = q \mathbf{v}, \quad (2.14)$$

called the **electric current element** of the material point. The individual image of a material system in space and time, in addition to its magretic energy W_κ , is also given by the value of its magnetic energy W_ν . The energy W_ν of two material points is proportional to the scalar product of their electric current elements $\mathbf{j}_1, \mathbf{j}_2$ divided by c and inversely proportional to the distance r between them

$$W_\nu = \mu_0 \frac{\mathbf{j}_1 \cdot \mathbf{j}_2}{c^2 r} = \mu_0 \frac{q_1 q_2}{c^2} \frac{\mathbf{v}_1 \cdot \mathbf{v}_2}{r}. \quad (2.15)$$

The coupling constant μ_0 is called the **magnetic constant** and it is equal to the inverse electric constant, thus $\mu_0 = 1/\epsilon_0$.

Remark. In the SI system of units it is assumed that $\mu_0 = 1/\epsilon_0 c^2$.

2.3. AXIOM FOR THE CONSERVATION OF ENERGY

The five types of energy U_κ , U_o , E_o , W_κ , W_o of a material system are functions of time and their numerical values can, in general, vary with time. The unproved assertion about the change of the energies of a material system in time is given by the following **axiom for the conservation of energy**, expressing the philosophical principle about the unity of space and time :

Axiom IX. Full energy H_o of a material system is called the sum of the time energy E_o and the space energy U . **Total energy** \tilde{H}_o is the full energy plus the space-time energy W . The numerical value of the total energy of an isolated material system remains constant in time, that is

$$d\tilde{H}_o = 0. \quad (2.16)$$

2.4. HIGH VELOCITY AXIOM

On the grounds of the nine axioms formulated above, the theory of **classical non-relativistic physics** can be built, i.e., of classical physics in which we assume the velocities of the material points to be too small in comparison with light velocity c . Whether we can consider the velocities of the material points small in comparison with light velocity depends on the precision with which we wish to consider the given physical problem.

At velocities of the material points comparable with c , we must take into account also the tenth axiom which, together with the first nine axioms, represents the axiomatical grounds of **classical relativistic physics**.

Conventional physics assumes that information can be transferred from one space point to another only if a certain quantity of energy can be sent from the first space point to the second. However, this is not true. Indeed, let us have a rotating rigid shaft on whose ends two identical cog-wheels are fixed and let us number any two cogs which lie opposite each other on the ends of a certain generatrix of the shaft. Let us assume that the shaft rotates with a constant angular velocity and there is no friction or torsion. Then, if a certain cog of the first cog-wheel makes contact with an indicator placed at one end of the shaft, we know that the corresponding cog of the other cog-wheel will also make contact with an indicator placed symmetrically at the opposite end

of the shaft. Obviously, in such a case, between both these space points no transfer of energy takes place, however, there is an information link between these points.

We call the synchronization of spatially separated clocks by the help of a rotating rigid shaft placed between them a **Newtonian time synchronization**. A Newtonian time synchronization can be realized also by the help of signals which proceed with the same velocity in any direction, after taking into account the time delays which the signals need to cover the different distances to the clocks placed at different space points.

If we synchronize spatially separated clocks, interchanging light signals between them, and *assume* that the velocity of light has the same numerical value in all directions with respect to any inertial frame, then we call this an **Einsteinian time synchronization**. The Einsteinian time synchronization can be reduced to a Newtonian time synchronization only if the frame in which we are working is attached to absolute space. In any frame moving with respect to absolute space the Einsteinian time synchronization differs from the Newtonian since in moving frames the velocity of light is anisotropic.

In Marinov (1975a) we show that the Newtonian time synchronization leads to the Galilean transformation and the Einsteinian time synchronization leads to the Lorentz transformation. It turns out, however, that space coordinates are involved in the Lorentz transformation formulas for time, and this implies that the constancy and isotropy of light velocity is essentially only a convention.

The mathematical apparatus for a description of high-velocity physics adequate to physical reality is to be obtained by assuming the following **high-velocity (relativistic) axiom** :

Axiom X. The material points called photons move with velocity c along all directions in absolute space and their velocity does not depend on their history. Light clocks with equal « arms » have the same rate in any inertial frame, independent of the orientation of their « arms ». At any point of any frame the time unit is to be defined by the period of light clocks with equal « arms », independent of the velocity of the frame and the local concentration of matter.

Here are some remarks on this axiom :

When we say that the velocity of the photons does not depend on their history, we mean that it does not depend on the velocity of the source of radiation, nor on the velocities of all material points with which the photon has collided, nor on which it was « hitched » (Marinov, 1974a), and nor on the material systems, i.e., on the potential fields, crossed by the photon.

The most important unproved assertion of our tenth axiom affirms that the rate of any proper light clock does not depend on the orientation of its « arm ». This assertion represents a crucial boundary between non-relativistic and relativistic mechanics which has concerned the human mind almost the whole of this century. Indeed, if we try to find the rates of two identical light clocks proceeding with velocity v with respect to absolute space when their « arms » are, respectively, perpendicular and parallel to v , then the non-relativistic conceptions should lead to the result that to n_{per} periods of the « transverse » light clock

$$n_{\text{par}} = n_{\text{per}} (1 - v^2/c^2)^{1/2} \quad (2.17)$$

periods of the « longitudinal » light clock will correspond, supposing (as we shall always do) that the « arms » of the clocks are equal.

Indeed, if we denote by $T'_{\text{per}} = T''_{\text{per}} = T_{\text{per}}/2$ the times in which light covers the « arm » d of the « transverse » clock « there » and « back », we shall have for these two cases

$$c^2 T_{\text{per}}'^2 = d^2 + v^2 T_{\text{per}}'^2, \quad c^2 T_{\text{per}}''^2 = d^2 + v^2 T_{\text{per}}''^2, \quad (2.18)$$

from where

$$T_{\text{per}} = T'_{\text{per}} + T''_{\text{per}} = \frac{2d}{c(1 - v^2/c^2)^{1/2}}. \quad (2.19)$$

On the other hand, if we denote by T'_{par} and T''_{par} the times in which light covers the « arm » d of the « longitudinal » clock « there » (i.e., along the direction of propagation of the clock) and « back » (i.e., against the direction of propagation of the clock), we shall have for these two cases

$$cT'_{\text{par}} = d + vT'_{\text{par}}, \quad cT''_{\text{par}} = d - vT''_{\text{par}} \quad (2.20)$$

from where

$$T_{\text{par}} = T'_{\text{par}} + T''_{\text{par}} = \frac{2d}{c(1 - v^2/c^2)}. \quad (2.21)$$

Hence it will be

$$T_{\text{per}} = T_{\text{par}} (1 - v^2/c^2)^{1/2} \quad (2.22)$$

and if for a certain time t the « transverse » light clock makes n_{per} « ticks » and the « longitudinal » n_{par} « ticks », it will be

$$t = n_{\text{per}} T_{\text{per}}, \quad t = n_{\text{par}} T_{\text{par}}. \quad (2.23)$$

From (2.23) and (2.22) we obtain (2.17).

Our tenth axiom asserts, however, that it must be

$$n_{\text{par}} = n_{\text{per}}, \quad (2.24)$$

and this empirical fact was first proved by the historical Michelson-Morley experiment.

It can be shown that the empirical fact (2.24) contradicts the Galilean transformation (as a matter of fact we have just shown this). The Lorentz transformation leads to the result (2.24); however, when treated from a « relativistic » point of view, it has failed to explain other experiments, such as our « coupled-mirrors » experiment.

In the next section we shall show that our tenth axiom leads to a transformation of the space and time coordinates we have called the Marinov transformation, and which is different from those of Galilei and Lorentz. However, in a certain aspect, it represents a *synthesis* of these two, and is to be considered as a companion of the Lorentz transformation, showing how the latter is to be treated from an absolute point of view.

§3. COORDINATE TRANSFORMATIONS

3.1. THE GALILEAN TRANSFORMATION

All transformations of the space and time coordinates which we consider in this section are between a frame K attached to absolute space and a frame K' moving inertially with a velocity V . To avoid trivial constants, we shall consider the so-called **homogeneous transformation**, i.e., we shall suppose that at the initial zero moment the origins of both frames have coincided (see fig. 3-1 where for simplicity's sake a two-dimensional case is presented).

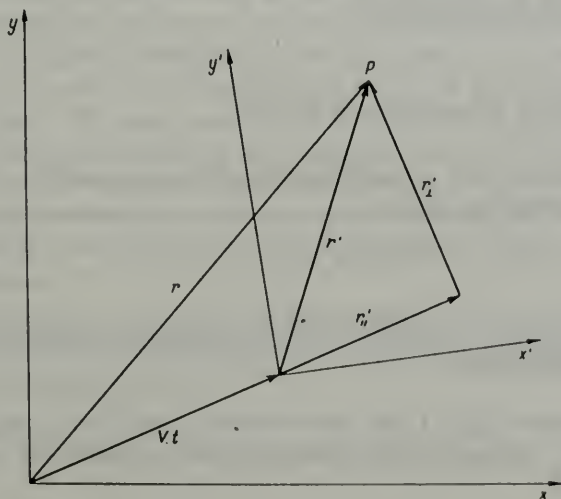

Fig. 3-1

Let us have a point P whose radius vector in frame K is \mathbf{r} (called the **absolute radius vector**) and whose radius vector in frame K' is \mathbf{r}' (called the **relative radius vector**). The radius vector of the origin of frame K' in frame K is \mathbf{R} (called the **transient radius vector**). It is

$$\mathbf{R} = \mathbf{V}t = \mathbf{V}_0 t_0, \quad (3.1)$$

where t is the time read on a clock which is at rest in frame K (an absolute clock) and \mathbf{V} is the velocity of frame K' measured on this clock, while t_0 is the time read on a clock which is at rest in K' (a proper clock) and \mathbf{V}_0 is the velocity of frame K' measured on this clock.

According to the traditional Newtonian conceptions, we shall have

$$\mathbf{r}' = \mathbf{r} - \mathbf{V}t, \quad (3.2)$$

$$\mathbf{r} = \mathbf{r}' + \mathbf{V}_0 t_0. \quad (3.3)$$

Adding these two equations, we obtain (3.1). If we assume that the clocks attached to K and K' read the same time, we have

$$t = t_0, \quad \mathbf{V} = \mathbf{V}_0. \quad (3.4)$$

Thus in such a case we can write the transformation formulas for the space and time coordinates in the form

$$\mathbf{r}' = \mathbf{r} - \mathbf{V}t, \quad t_0 = t, \quad (3.5)$$

$$\mathbf{r} = \mathbf{r}' + \mathbf{V}t, \quad t = t_0. \quad (3.6)$$

Formulas (3.5) represent the direct, and formulas (3.6) the inverse homogeneous **Galilean transformation**.

3.2. THE LORENTZ TRANSFORMATION

Now we shall search for a transformation of the space and time coordinates which will lead to the relation

$$T_{\text{per}} = T_{\text{par}} \quad (3.7)$$

between the periods of « transverse » and « longitudinal » light clocks, as required by our tenth axiom.

Let us decompose (fig. 3-1) the radius vectors \mathbf{r} and \mathbf{r}' into components \mathbf{r}_{per} , \mathbf{r}'_{per} and \mathbf{r}_{par} , \mathbf{r}'_{par} , respectively, perpendicular and parallel to the direction of propagation of K' .

According to the traditional Newtonian conceptions, we have

$$\mathbf{r}' = \mathbf{r}'_{\text{per}} + \mathbf{r}'_{\text{par}} = \mathbf{r}_{\text{per}} + (\mathbf{r}_{\text{par}} - Vt) = \mathbf{r} - Vt. \quad (3.8)$$

We can meet the requirement (3.7) of our tenth axiom if we take the parallel component of the relative radius vector contracted by the factor $(1 - V^2/c^2)^{1/2}$ when expressed by the coordinates in frame K , i.e., if we *axiomatically* assume as valid instead of the Newtonian relations

$$\mathbf{r}_{\text{per}} = \mathbf{r}'_{\text{per}}, \quad \mathbf{r}_{\text{par}} - Vt = \mathbf{r}'_{\text{par}} \quad (3.9)$$

the « Lorentzian » relations

$$\mathbf{r}_{\text{per}} = \mathbf{r}'_{\text{per}}, \quad \mathbf{r}_{\text{par}} - Vt = \mathbf{r}'_{\text{par}} (1 - V^2/c^2)^{1/2}. \quad (3.10)$$

This « contraction » (when $\mathbf{r}_{\text{par}} - Vt$ is expressed by \mathbf{r}'_{par}) or « dilation » (when \mathbf{r}'_{par} is expressed by $\mathbf{r}_{\text{par}} - Vt$) is neither a physical effect, as *supposed* by Lorentz, nor a result of measurement, as *obtained* by Einstein. According to our theory, \mathbf{r}'_{par} and $\mathbf{r}_{\text{par}} - Vt$ represent the *same* length (distance) between two material points which can be connected by a rigid rod or which can move with respect to each other, or between two non-material points, taken at a given moment. (N.B. About lengths one can speak only at a given moment !) Thus \mathbf{r}'_{par} and $\mathbf{r}_{\text{par}} - Vt$ are *equal* and we write the second relation (3.10) only because the velocity of light has *not* an exact aether-Newtonian character. Making a transition from (3.9) to (3.10) we introduce a *blunt mathematical contradiction* into the traditional Newtonian mathematical apparatus. As we have shown in detail in Marinov (1975a), this mathematical contradiction remains for ever in the formulas and we must state that after years of intensive mathematical speculations we could not find a way to get rid of it. We ask the reader to pay due attention to this statement and not to blame our theory for mathematical imperfection. This imperfection exists in Nature itself. We must realize once and for all that light has not an exact aether-Newtonian character of propagation since its « there-and-back » velocity (in a frame moving in absolute space) is isotropic, while according to the **aether-Newtonian** conceptions it must be anisotropic. We have called this peculiarity in the propagation of light the **aether-Marinov** character of light propagation.

Thus, if we wish to meet the requirement (3.7), we have to write instead of the relation (3.8) the following relation for the transformation of the radius vectors in frames K and K'

$$\mathbf{r}' = \mathbf{r}'_{\text{per}} + \mathbf{r}'_{\text{par}} = \mathbf{r}_{\text{per}} + \frac{\mathbf{r}_{\text{par}} - Vt}{(1 - V^2/c^2)^{1/2}}. \quad (3.11)$$

This formula, written in such a manner that only the absolute radius vector r is represented, but not its transverse and longitudinal components $r_{\text{per}}, r_{\text{par}}$, has the form

$$r' = r + \left\{ \left[\frac{1}{(1 - V^2/c^2)^{1/2}} - 1 \right] \frac{r \cdot V}{V^2} - \frac{t}{(1 - V^2/c^2)^{1/2}} \right\} V. \quad (3.12)$$

Let us now find the formula for the inverse transformation, i.e., from r' to r . Here we have two possibilities :

a) To assume that also in frame K' the velocity of light is isotropic and equal to c (the Einstein way).

b) To assume that the velocity of light is isotropic and equal to c only in frame K which is attached to absolute space (the Marinov way).

The Einstein way leads to transformation of the time coordinates where the radius vectors should appear, i.e., to relative time coordinates, while the Marinov way leads to transformation of the time coordinates where the radius vectors should not appear, i.e., to absolute time coordinates.

Now we shall follow the first way and in §3.3 the second.

If the velocity of light in frame K' is *assumed* to be isotropic and equal to c , then, assuming further that the velocity with which frame K moves with respect to K' (and measured on a clock attached to K') is equal with opposite sign to the velocity V with which frame K' moves with respect to K (and measured on a clock attached to K), we can write (let us note that both these assumptions follow from the principle of relativity)

$$r = r' + \left\{ \left[\frac{1}{(1 - V^2/c^2)^{1/2}} - 1 \right] \frac{r' \cdot V}{V^2} + \frac{t'}{(1 - V^2/c^2)^{1/2}} \right\} V. \quad (3.13)$$

Adding formulas (3.12) and (3.13), we obtain

$$\begin{aligned} & - \left[\frac{1}{(1 - V^2/c^2)^{1/2}} - 1 \right] \frac{r \cdot V}{V^2} + \frac{t}{(1 - V^2/c^2)^{1/2}} = \\ & = \left[\frac{1}{(1 - V^2/c^2)^{1/2}} - 1 \right] \frac{r' \cdot V}{V^2} + \frac{t'}{(1 - V^2/c^2)^{1/2}}. \end{aligned} \quad (3.14)$$

If in this formula we substitute r' from (3.12), we shall obtain the transformation formula for time in which t' will be expressed through t and r

$$t' = \frac{t - r \cdot V/c^2}{(1 - V^2/c^2)^{1/2}}. \quad (3.15)$$

On the other hand, if in formula (3.14) we substitute \mathbf{r} from (3.13), we shall obtain the transformation formula for time in which t will be expressed through t' and \mathbf{r}'

$$t = \frac{t' + \mathbf{r}' \cdot \mathbf{V}/c^2}{(1 - V^2/c^2)^{1/2}}. \quad (3.16)$$

Formulas (3.12), (3.15) represent the direct, and formulas (3.13), (3.16) the inverse homogeneous **Lorentz transformation**. These formulas show that not only the radius vectors \mathbf{r} and \mathbf{r}' are two different quantities, but also the time coordinates t and t' are two different quantities and are to be called **absolute time coordinate** and **relative time coordinate**.

Thus, since the time coordinates in the Lorentz transformation are relative quantities, the light velocity constancy in this transformation is only *apparent*. In Marinov (1975a), we show how, proceeding from the Lorentz transformation, one can obtain the expressions for the light velocity in any inertial frame which are adequate to physical reality. Hence, according to absolute space-time theory, the Einstein general principle of relativity is invalid and the Lorentz transformation is adequate to physical reality only if it is treated from our absolute point of view. Since Einstein treats the light velocity constancy as a physical fact and the general principle of relativity as a law of Nature, we consider the Lorentz transformation in the context of special relativity as inadequate to physical reality.

Note that we consider the Galilei limited principle of relativity as adequate to physical reality. This principle asserts that there is no mechanical physical phenomenon by whose help one can establish the inertial motion of a given material system. Hence for the mechanical phenomena any inertial relative space is isotropic.

For the electromagnetic phenomena the principle of relativity does not hold good. Thus for the electromagnetic phenomena the inertial relative spaces are not isotropic.

However, as Minkowski has shown, if we consider a 4-space in which the three space coordinates in any inertial frame are unified with the corresponding time coordinate multiplied by c (and by the imaginary unit), then this 4-space turns out to be isotropic and homogeneous. As the Galilean transformations make a group in the 3-space, so the Lorentz transformations make a group in the 4-space. This is an exclusively great mathematical advantage and the 4-dimensional mathematical apparatus developed by Minkowski has given an enormous help in the investigation of high-velocity physical phenomena.

In our absolute space-time theory, we work intensively with the 4-dimensional mathematical formalism of Minkowski, always keeping in mind

that the fourth dimension is not a time axis but a length axis along which the time coordinates are multiplied by the velocity of light, and here the apparent absoluteness of the light velocity is always connected with the relativity of the time coordinates. As a matter of fact, the time coordinates are absolute and light velocity relative, as in the Marinov transformation and as we have shown by the help of numerous experiments analysed in Part II of this book.

We must note and emphasize that if setting experiments where only electromagnetic phenomena are involved, then the principle of relativity apparently holds good because of the mutual annihilation of the appearing absolute effects. This principle breaks down only when setting experiments where combined electromagnetic and mechanical phenomena are involved, as is the case with the « coupled-mirrors » experiment, the « antipodal-clocks » experiment and the ultrasonic « coupled-shutters » experiment.

3.3. THE MARINOV TRANSFORMATION

As a result of our theoretical and experimental work, we have come to the conclusion that *time is an absolute quantity* and the Marinov transformation (Marinov, 1978d) is adequate to physical reality. By the help of this transformation, one can explain all high-velocity experiments, including those which contradict the Galilean as well as the Lorentz transformation, if the latter be treated in the frame of special relativity.

To obtain the Marinov transformation, we shall proceed from our tenth axiom (§2.4), noting that now we shall not take into account the influence of the gravitating masses on the rates of the light clocks, a problem considered in Marinov (1976a).

Thus, according to the tenth axiom :

a) Light clocks with equal « arms » have the same rate, independent of the orientation of their « arms ».

b) In any frame the time unit is to be defined by the period of light clocks with equal « arms », independent of the velocity of the frame.

As we have shown in §2.4, the first assertion drastically contradicts the traditional Newtonian conceptions. The second assertion represents not such a drastic contradiction because in the frame of the traditional Newtonian space-time conceptions also one can define the time unit in any inertial frame by the period of light clocks with equal « arms ». However, in the traditional Newtonian frame, the inconvenience exists that one has further to define that the « arms » of the light clocks must always make the same angle with the velocity of the inertial frame used, *e.g.*, their « arms » must be perpendicular to this velocity. In such a manner the absolute time dilation phenomenon will be introduced also into the traditional Newtonian theory. Thus, at first

glance, it seems that the second assertion has not such a « natural » character as the first one and represents only a stipulation. However, it turns out that not only the periods of light clocks become greater when they move with greater velocity in absolute space (we repeat, a phenomenon which exists also in the traditional Newtonian theory) but also the periods of many other physical processes (the periods of atomic clocks, the mean-lives of decaying elementary particles). So far there is no experimental evidence permitting one to assert that the period of any system (say, the period of a spring clock, the pulse of a man) becomes greater with the increase of its absolute velocity. This problem needs additional theoretical and experimental investigation. At any rate, we think the statement about the time dilation is to be considered not as a stipulation but as an axiomatic assertion alien to the traditional Newtonian theory.

Let us find first how the Galilean transformation formulas are to be written if one should assume that in any inertial frame the time unit is to be defined by the period of light clocks with equal « arms », supposing for definiteness that the « arms » of the light clocks must be always perpendicular to the absolute velocity of the frames.

The period of an absolute light clock (see p.15) whose « arm » is d will be

$$T = 2d/c. \quad (3.17)$$

A proper light clock with the same « arm » which moves with velocity V in absolute space will have a period [see (2.19)]

$$T_0 = \frac{2d}{c(1 - V^2/c^2)^{1/2}} = \frac{T}{(1 - V^2/c^2)^{1/2}}. \quad (3.18)$$

If (at an appropriate choice of d) we choose T as a time unit in frame K (called **absolute second**) and T_0 as a time unit in frame K' (called **proper second**), then it is clear that when between two events, t absolute seconds and t_0 proper seconds have elapsed, the relation between them will be

$$t_0/t = T/T_0 = (1 - V^2/c^2)^{1/2}, \quad (3.19)$$

where T and T_0 are measured in the *same* time units (absolute or proper). Under this stipulation we shall obtain from (3.1) and (3.19)

$$V_0 = \frac{V}{(1 - V^2/c^2)^{1/2}}, \quad V = \frac{V_0}{(1 + V_0^2/c^2)^{1/2}}. \quad (3.20)$$

Thus the transformation formulas (3.2), (3.3) to which we attach the relation (3.19) are to be written in the following form

$$\mathbf{r}' = \mathbf{r} - Vt, \quad t_0 = t(1 - V^2/c^2)^{1/2}, \quad (3.21)$$

$$\mathbf{r} = \mathbf{r}' + V_0 t_0, \quad t = t_0 (1 + V_0^2/c^2)^{1/2}. \quad (3.22)$$

Formulas (3.21) represent the direct, and formulas (3.22) the inverse homogeneous **relativistic Galilean transformation**.

In these formulas, V is the velocity of frame K' with respect to absolute space (i.e., to frame K) measured in absolute seconds (called the **absolute transient velocity**), V_0 is the same velocity measured in proper seconds (called the **proper transient velocity**) and c is the velocity of light along the « arm » of the absolute clock measured in absolute seconds, as well as along the « arm » of the proper clock measured in proper seconds.

If, when proceeding from the traditional Newtonian conceptions, one would come to the result that a « transverse » and a « longitudinal » light clock would have the same rate, then a transformation of the space and time coordinates adequate to physical reality, at the assumption of the time dilation dogma, would be given by the relativistic Galilean transformation. However, the traditional Newtonian conceptions lead to the conclusion that a « transverse » and a « longitudinal » light clock have different rates (see §2.4). On the other hand, the experiment (the historical Michelson-Morley experiment was the first one) has shown that the rates of a « transverse » and a « longitudinal » light clock are equal. We have assumed this empirical fact as an axiomatical assertion, *without trying to explain why Nature works in such a manner*. The introduction of this axiomatical (empirical) assertion into the Galilean transformation leads to the Marinov transformation.

This is to be done in the following manner : exactly in the same way as in §3.2, we come to the conclusion that if we wish to meet the requirement of our tenth axiom about the independence of the light clock's rate on the orientation of the clock's « arm », the transformation between the radius vectors \mathbf{r} and \mathbf{r}' is to be written in the form (3.12).

To obtain the inverse transformation, we proceed from the formula [see (3.10), (3.1) and (3.20)]

$$\begin{aligned} \mathbf{r} &= \mathbf{r}_{\text{per}} + \mathbf{r}_{\text{par}} = \mathbf{r}'_{\text{per}} + \mathbf{r}'_{\text{par}} (1 - V^2/c^2)^{1/2} + V t = \\ &= \mathbf{r}'_{\text{per}} + \frac{\mathbf{r}'_{\text{par}}}{(1 + V_0^2/c^2)^{1/2}} + V_0 t_0. \end{aligned} \quad (3.23)$$

This formula, written in such a manner that only the relative radius vector \mathbf{r}' is represented, but not its perpendicular and parallel components \mathbf{r}'_{per} , \mathbf{r}'_{par} , will have the form

$$\mathbf{r} = \mathbf{r}' + \left\{ \left[\frac{1}{(1 + V_0^2/c^2)^{1/2}} - 1 \right] \frac{\mathbf{r}' \cdot V_0}{V_0^2} + t_0 \right\} V_0. \quad (3.24)$$

If we express here V_0 through V according to the first formula (3.20), then from (3.12) and (3.24), in a manner similar to that used in §3.2, we can obtain the second formula (3.21). On the other hand, if in (3.12) we express V through V_0 according to the second formula (3.20), then from (3.12) and (3.24) we can obtain the second formula (3.22).

Let us combine formula (3.12) with the second formula (3.21) and formula (3.24) with the second formula (3.22)

$$r' = r + \left\{ \left[\frac{1}{(1 - V^2/c^2)^{1/2}} - 1 \right] \frac{r \cdot V}{V^2} - \frac{t}{(1 - V^2/c^2)^{1/2}} \right\} V, \\ t_0 = t(1 - V^2/c^2)^{1/2}, \quad (3.25)$$

$$r = r' + \left\{ \left[\frac{1}{(1 + V_0^2/c^2)^{1/2}} - 1 \right] \frac{r' \cdot V_0}{V_0^2} + t_0 \right\} V_0, \\ t = t_0(1 + V_0^2/c^2)^{1/2}. \quad (3.26)$$

Formulas (3.25) represent the direct, and formulas (3.26) the inverse homogeneous **Marinov transformation**.

Let us now obtain the Marinov transformation formulas for velocities. Writing in the first formulas (3.25) and (3.26) dr, dt, dr', dt_0 instead of r, t, r', t_0 , dividing them by dt and introducing the notations $\mathbf{v} = dr/dt, \mathbf{v}' = dr'/dt$, we obtain

$$\mathbf{v}' = \mathbf{v} + \left\{ \left[\frac{1}{(1 - V^2/c^2)^{1/2}} - 1 \right] \frac{\mathbf{v} \cdot V}{V^2} - \frac{1}{(1 - V^2/c^2)^{1/2}} \right\} V, \quad (3.27)$$

$$\mathbf{v} = \mathbf{v}' + \left\{ \left[(1 - V^2/c^2)^{1/2} - 1 \right] \frac{\mathbf{v}' \cdot V}{V^2} + 1 \right\} V. \quad (3.28)$$

The velocities \mathbf{v} and \mathbf{v}' are measured in absolute time. Thus \mathbf{v} must be called the **absolute absolute velocity** (as a rule, the first adjective « absolute » will be omitted) and \mathbf{v}' **absolute relative velocity** (as a rule, the adjective « absolute » will be omitted). For this reason we have written in (3.28) the absolute transient velocity V and not the proper transient velocity V_0 . Formula (3.27) represents the direct, and formula (3.28) the inverse **Marinov transformation for velocities** written in *absolute time*.

Writing in the first formulas (3.25) and (3.26) dr, dt, dr', dt_0 instead of r, t, r', t_0 , dividing them by dt_0 and introducing the notations $\mathbf{v}_0 = dr/dt_0$ for the **proper absolute velocity** and $\mathbf{v}'_0 = dr'/dt_0$ for the **proper relative velocity**, we can obtain the Marinov transformation for velocities written in *proper time*.

One can write also the transformation formulas for velocities in which the relative velocity is expressed in proper time and the absolute velocity in absolute time. This will be the Marinov transformation for velocities written in *mixed time*.

Now we shall write the transformation formulas for the velocities' magnitudes. Denoting the angle between \mathbf{v} and V by θ and the angle between \mathbf{v}' and V by θ' , we can write formulas (3.27) and (3.28) in the following form, after having squared them,

$$v'^2 = \frac{v^2 (1 - V^2 \sin^2 \theta / c^2) - 2 v V \cos \theta + V^2}{1 - V^2 / c^2}, \quad (3.29)$$

$$v^2 = v'^2 (1 - V^2 \cos^2 \theta' / c^2) + 2 v' V \cos \theta' (1 - V^2 / c^2)^{1/2} + V^2. \quad (3.30)$$

If we suppose $v = c$ and if we write $v' = c'$, where c' is the relative light velocity measured in absolute time, i.e., the **absolute relative light velocity** (as a rule, the adjective « absolute » will be omitted), then these two equations (the second after a solution of a quadratic equation with respect to v') give

$$c' = c \frac{1 - V \cos \theta / c}{(1 - V^2 / c^2)^{1/2}} = c \frac{(1 - V^2 / c^2)^{1/2}}{1 + V \cos \theta' / c}. \quad (3.31)$$

If we denote by c'_0 the **proper relative light velocity**, then its connection with the **absolute absolute light velocity** (as a rule, the first adjective « absolute » will be omitted) c will be

$$c'_0 = c \frac{1 - V \cos \theta / c}{1 - V^2 / c^2} = \frac{c}{1 + V \cos \theta' / c}, \quad (3.32)$$

and its connection with the **proper absolute light velocity**

$$c_0 = \frac{c}{(1 - V^2 / c^2)^{1/2}} \quad (3.33)$$

will be the same as that given by formula (3.31).

Note that the velocities with respect to the moving frame K' are called relative, while the clocks attached to K' are called proper. On the other hand, the velocities with respect to the rest frame K are called absolute and the clocks attached to K are also called absolute. To have in the second case a terminological difference similar to the first case, we have considered calling the absolute clock and absolute time « universal ». However, finally we decided to use a single word, even though this might sometimes lead to misunderstandings, because of the confusion in using too many different terms.

We designate the relative quantities by upperscripts (primes) and the proper quantities by subscripts (zeros). For this reason, in the Lorentz transformation (where time is relative), we designate the relative time coordinates by upperscripts (primes) and in the Marinov transformation (where time is absolute), we designate the proper time coordinates by subscripts (zeros).

The distances are always absolute. However, the aether-Marinov character of light propagation leads to the introduction of the notion « proper distance ». The problem about the eternal contradiction between proper distances and distances is considered in detail in Marinov (1975a). Here we must again repeat that the absolute and proper time intervals are *physically different quantities*, while the difference between proper distances and distances is only a *contradictory mathematical result* which appears because of the aether-Marinov character of light propagation engendered by the bi-directional light velocity isotropy in any inertial frame.

3.4. GROUP PROPERTIES OF THE MARINOV TRANSFORMATION

After a due examination of the Marinov transformations, it can easily be established that they form a group. Since the mathematical analysis in the general case is too cumbersome, we shall suppose, for simplicity's sake, that the velocities of the different frames and their x -axes are parallel to the x -axis of the rest (absolute) frame. As in this simple case the y - and z -coordinates are subjected to an identical transformation, we shall ignore them.

From formulas (3.25) we obtain the following direct transformation between the coordinates (x, t) in the absolute frame K and the coordinates (x_2, t_2) in a proper frame K_2 moving with velocity V_2 ($V_2 \leq 0$) along the positive direction of the x -axis

$$x_2 = \frac{x - V_2 t}{(1 - V_2^2/c^2)^{1/2}}, \quad t_2 = t (1 - V_2^2/c^2)^{1/2}. \quad (3.34)$$

The inverse transformation between the coordinates (x_1, t_1) in a proper frame K_1 moving with velocity V_1 ($V_1 \leq 0$) along the positive direction of the x -axis of the rest frame K and the coordinates (x, t) in K , according to formulas (3.26) [see also formulas (3.20)], is

$$x = x_1 (1 - V_1^2/c^2)^{1/2} + \frac{V_1 t_1}{(1 - V_1^2/c^2)^{1/2}}, \quad t = \frac{t_1}{(1 - V_1^2/c^2)^{1/2}}, \quad (3.35)$$

where the velocities V_1 and V_2 are measured in absolute time.

Substituting formulas (3.35) into formulas (3.34), we can express the coordinates in frame K_2 through the coordinates in frame K_1 ,

$$x_2 = x_1 \left(\frac{1 - V_1^2/c^2}{1 - V_2^2/c^2} \right)^{1/2} + t_1 \frac{V_1 - V_2}{(1 - V_1^2/c^2)^{1/2}(1 - V_2^2/c^2)^{1/2}},$$

$$t_2 = t_1 \left(\frac{1 - V_2^2/c^2}{1 - V_1^2/c^2} \right)^{1/2}. \quad (3.36)$$

These formulas are absolutely symmetric with respect to the coordinates in both frames. Now we shall prove that these transformations form a group.

A set of transformations, T_{12} , T_{23} , T_{14} , ..., forms a group if it has the following properties :

1. **Transitive property** : The product of two transformations of the set is equivalent to a member of the set, the product

$$T_{13} = T_{12} T_{23} \quad (3.37)$$

being defined as performing T_{12} and T_{23} successively.

If formulas (3.36) give a transformation T_{12} , a transformation T_{23} will have the same form in which the number 1 is replaced by 2 and the number 2 by 3. Substituting formulas (3.36) for the transformation T_{12} into the corresponding formulas for the transformation T_{23} , we obtain a transformation T_{13} which has the same form as (3.36) in which the number 2 is replaced by 3.

Thus the transitive property is proved right. We mention here that the transitive property for the Lorentz and Galilean transformations can be proved only if one takes into account the corresponding transformation for velocities. The transitive property for the Marinov transformation is proved *directly*, i.e., without taking into account the transformation for velocities.

2. **Identity property** : The set includes one « identity » transformation, T_{11} , whose product with any other member of the set leaves the latter unchanged. Thus

$$T_{12} T_{22} = T_{11} T_{12} = T_{12}. \quad (3.38)$$

The identify form of the transformation (3.36) occurs for $V_1 = V_2$.

3. **Reciprocal property** : Every member of the set has a unique reciprocal (or inverse) which is also a member of the set. Thus the inverse of T_{12} is T_{21} , where T_{21} is a member of the set, and

$$T_{12} T_{21} = T_{11}. \quad (3.39)$$

The reciprocal of the transformation (3.36) can be obtained by writing the number 2 instead of 1, and *vice versa*.

4. Associative property: If three succeeding transformations are performed, then

$$T_{12} (T_{23} T_{34}) = (T_{12} T_{23}) T_{34} . \quad (3.40)$$

The associative property can easily be proved.

Thus the Marinov transformations form a group.

§ 4. ELEMENTS OF MOTION

4.1. VELOCITY

As already stated (§3.3), we introduce the following two types of velocity :

The **velocity**

$$\mathbf{v} = \frac{d\mathbf{r}}{dt} . \quad (4.1)$$

The **proper velocity**

$$\mathbf{v}_0 = \frac{d\mathbf{r}}{dt_0} = \frac{d\mathbf{r}}{dt (1 - v^2/c^2)^{1/2}} = \frac{\mathbf{v}}{(1 - v^2/c^2)^{1/2}} . \quad (4.2)$$

For example, consider a car moving along a given road which we suppose at rest in absolute space. Two policemen, the distance between whom is dr , supplied with two clocks (imagine for clarity, light clocks) which are synchronized by the help of a long rotating rigid shaft (i.e., by the help of a Newtonian time synchronization), will register the time dt in which the car will cover the distance and, thus, will measure the velocity v of the car. The driver supplied with a single clock will register the proper time dt_0 in which the car will cover the *same* distance and, thus, will measure the proper velocity v_0 . Obviously, the driver will always register a higher velocity and even when he surpasses the prescribed speed limit (according to his calculation) he would not be stopped by the policemen to pay a fine.

In relativistic physics, we work with the proper velocities (in general, with the proper elements of motion) because *in such a case the problem about the synchronization of spatially separated clocks is eliminated*.

The proper velocity represents the space part of a 4-vector called the 4-velocity. The time component of the 4-velocity is the proper light velocity [see (3.33)]

$$c_o = \frac{d(c t)}{dt_o} = \frac{c}{(1 - v^2/c^2)^{1/2}}. \quad (4.3)$$

The product of the mass of a material point by its velocity is called the momentum; thus

$$\mathbf{p} = m \mathbf{v}, \quad \mathbf{p}_o = m \mathbf{v}_o \quad (4.4)$$

are, respectively, the **momentum** and **proper momentum** of the material point.

4.2. ACCELERATION

We introduce the following three types of acceleration :

The acceleration

$$\mathbf{u} = \frac{d\mathbf{v}}{dt} = \frac{d^2\mathbf{r}}{dt^2}. \quad (4.5)$$

The first proper acceleration

$$\mathbf{u}_o = \frac{d\mathbf{v}_o}{dt} = \frac{d}{dt} \left(\frac{d\mathbf{r}}{dt_o} \right) = \frac{\mathbf{u}}{(1 - v^2/c^2)^{1/2}} + \frac{\mathbf{v}}{c^2} \frac{\mathbf{v} \cdot \mathbf{u}}{(1 - v^2/c^2)^{3/2}}. \quad (4.6)$$

The second proper acceleration

$$\mathbf{u}_{oo} = \frac{d\mathbf{v}_{oo}}{dt_o} = \frac{d}{dt_o} \left(\frac{d\mathbf{r}}{dt_o} \right) = \frac{\mathbf{u}}{1 - v^2/c^2} + \frac{\mathbf{v}}{c^2} \frac{\mathbf{v} \cdot \mathbf{u}}{(1 - v^2/c^2)^2}. \quad (4.7)$$

The second proper acceleration represents the space part of a 4-vector called the 4-acceleration. The time component of the 4-acceleration can easily be expressed through the acceleration and velocity.

The product of the mass of a material point by its acceleration is called the kinetic force; thus

$$\mathbf{f} = m \mathbf{u}, \quad \mathbf{f}_o = m \mathbf{u}_o, \quad \mathbf{f}_{oo} = m \mathbf{u}_{oo} \quad (4.8)$$

are, respectively, the **kinetic force**, **first proper kinetic force** and **second proper kinetic force** of the material point.

4.3. SUPER-ACCELERATION

We introduce the following four types of super-acceleration :

The **super-acceleration**

$$w = \frac{d\mathbf{u}}{dt} = \frac{d^2\mathbf{v}}{dt^2} = \frac{d^2\mathbf{r}}{dt^2} . \quad (4.9)$$

The **first proper super-acceleration**

$$w_o = \frac{d\mathbf{u}_o}{dt} = \frac{d^2\mathbf{v}_o}{dt^2} = \frac{d^2}{dt^2} \left(\frac{d\mathbf{r}}{dt_o} \right) . \quad (4.10)$$

The **second proper super-acceleration**

$$w_{oo} = \frac{d\mathbf{u}_{oo}}{dt} = \frac{d^2\mathbf{v}_o}{dt dt_o} = \frac{d}{dt} \left[\frac{d}{dt_o} \left(\frac{d\mathbf{r}}{dt_o} \right) \right] . \quad (4.11)$$

The **third proper super-acceleration**

$$w_{ooo} = \frac{d\mathbf{u}_{oo}}{dt_o} = \frac{d}{dt_o} \left(\frac{d\mathbf{v}_o}{dt_o} \right) = \frac{d}{dt_o} \left[\frac{d}{dt_o} \left(\frac{d\mathbf{r}}{dt_o} \right) \right] . \quad (4.12)$$

Putting (4.7) into (4.12), we obtain the following expression for the third proper super-acceleration through the velocity, acceleration and super-acceleration of the material point

$$w_{ooo} = \frac{w}{(1 - v^2/c^2)^{3/2}} + \frac{3\mathbf{u}(\mathbf{v} \cdot \mathbf{u}) + \mathbf{v}u^2 + \mathbf{v}(\mathbf{v} \cdot \mathbf{w})}{c^2(1 - v^2/c^2)^{5/2}} + \frac{4\mathbf{v}}{c^4} \frac{(\mathbf{v} \cdot \mathbf{u})^2}{(1 - v^2/c^2)^{7/2}} . \quad (4.13)$$

The third proper super-acceleration represents the space part of a 4-vector called the 4-super-acceleration. The time component of the 4-super-acceleration can easily be expressed through the super-acceleration, acceleration and velocity.

For the product of the mass of a material point by its super-acceleration we do not introduce a special name and symbol.

§ 5. TIME ENERGY

5.1. THE NON-RELATIVISTIC CONSIDERATION

We obtain the form of the time energy of a material point with mass m in non-relativistic mechanics by integrating the axiomatical relation (2.11)

$$e_o = m v^2/2 + \text{Const.} \quad (5.1)$$

For $v = 0$ the time energy of the material point must be equal to its rest energy e_r which is given by the relation (2.3), so that we can assume $\text{Const} = e_r$, and thus

$$e_o = m c^2 + m v^2/2 = e_r + e_k, \quad (5.2)$$

The difference between the time and rest energies is called the **kinetic energy**. Thus, in non-relativistic mechanics, the kinetic energy has the form

$$e_k = m v^2/2. \quad (5.3)$$

5.2. THE RELATIVISTIC CONSIDERATION

To obtain the time energy of a material point in relativistic mechanics we have to put into the axiomatical assertion (2.11) the proper velocity \mathbf{v}_o , instead of the velocity \mathbf{v} . There are three possibilities

$$de^o = m \mathbf{v}_o \cdot d\mathbf{v}, \quad (5.4)$$

$$de_o = m \mathbf{v} \cdot d\mathbf{v}_o, \quad (5.5)$$

$$de_{oo} = m \mathbf{v}_o \cdot d\mathbf{v}_o, \quad (5.6)$$

and after the integration of these three formulas we obtain three different expressions for the time energy in relativistic mechanics

$$e^o = -m c^2 (1 - v^2/c^2)^{1/2}, \quad (5.7)$$

$$e_o = \frac{m c^2}{(1 - v^2/c^2)^{1/2}}, \quad (5.8)$$

$$e_{oo} = \frac{1}{2} \frac{m c^2}{1 - v^2/c^2}, \quad (5.9)$$

where all constants of integration are taken equal to zero, so that for $v \ll c$ we obtain

$$e^o = -m c^2 + m v^2/2 = -e_r + e_k, \quad (5.10)$$

$$e_o = m c^2 + m v^2/2 = e_r + e_k, \quad (5.11)$$

$$e_{oo} = m c^2/2 + m v^2/2 = e_r/2 + e_k. \quad (5.12)$$

Thus for $v \ll c$ the kinetic energy of all these three forms of the relativistic time energy has the same value as in non-relativistic mechanics, though their rest energies are different. Only the rest energy of e_o has the

value e_r postulated by our third axiom. The rest energies of e'' and $e_{'''}$ can be obtained equal to e_r if additional constants of integration are introduced. For this reason, we choose e_o as 'time (or proper) energy of the material point. However, we must emphasize that e'' and $e_{'''}$ can adequately play the same role.

We introduce the following terms :

e'' — **Lagrange time energy**,

e_o — **Hamilton time energy**,

$e_{'''}$ — **Marinov time energy**.

The proper energy divided by velocity of light represents the time part of a 4-vector called the 4-momentum whose space part is the proper momentum $\bar{p}_o = m \mathbf{v}_o$. This quantity is denoted by

$$\bar{p}_o = \frac{e_o}{c} = m c_o = \frac{m c}{(1 - v^2/c^2)^{1/2}} \quad (5.13)$$

and is called the **proper time momentum**; the quantity $\bar{p} = mc$ is called the **(absolute) time momentum**. Thus $\mathbf{p} = m\mathbf{v}$ can be called the **(absolute) space momentum**, \mathbf{v} and c , respectively, (absolute) space and time velocities, and so on.

Obviously, the Hamilton time energy e_o can be called the **proper time energy** and the rest energy e_r the **(absolute) time energy**, denoting it by the symbol e , when this cannot be confused with the charge of the electron; the latter, as a rule, is denoted by us by q_e (see axiom V).

All three types of time energy e'' , e_o , and $e_{'''}$ are used in theoretical physics. The time energy e_o plays the most important role, though many formulas obtain a more compact form when Lagrange time energy e'' is used [see, for example, (6.14)].

Comparing (5.8) with (2.4) [or the second relation (4.4) with (2.12) when taking into account (4.2)], we conclude that the relation between mass and proper mass is

$$m_o = \frac{m}{(1 - v^2/c^2)^{1/2}} \quad (5.14)$$

Note that the axiomatical relation (2.3) represents the famous Einstein formula which is considered as an « ideological basis » for modern physics in our nuclear century. As a matter of fact, relation (2.3) serves only for the introduction of a new *derivative* physical quantity which we call « mass » and which differs from the *axiomatical* quantity « energy » only by a constant factor. The whole of physics can be constructed without introducing at all the quantity « mass » because relation (2.3) represents a trivial tautology. However, the establishment of relation (2.3) was an enormous scientific feat.

The greatest accomplishment of a scientist is the revelation of a simple truth where others see a complexity or nothing at all. Almost the same can be said for de Broglie's relation (2.5), although we must add, that the particles-waves contradiction is still not lucidly resolved.

§ 6. THE LAGRANGE EQUATIONS

6.1. THE NON-RELATIVISTIC CONSIDERATION

As can be seen from (2.13) and (2.15), space-time energy is to be considered only in relativistic physics since its availability leads to effects of second order in v/c . Thus in non-relativistic physics we have to consider only space and time energies.

Let us assume that in a time dt the space energy U and the time energy E_0 of an isolated material system of n material points have changed their values by dU and dE_0 . Denote by \mathbf{r}_i , \mathbf{v}_i , \mathbf{u}_i , e_{0i} the radius vector, velocity, acceleration, and energy of the i th material point. As space energy depends only on the distances between the material points, we have

$$dU = \sum_{i=1}^n \frac{\partial U}{\partial \mathbf{r}_i} \cdot d\mathbf{r}_i. \quad (6.1)$$

Time energy depends only on the velocities of the material points and thus

$$dE_0 = \sum_{i=1}^n \frac{\partial E_0}{\partial \mathbf{v}_i} \cdot d\mathbf{v}_i = \sum_{i=1}^n \frac{\partial e_{0i}}{\partial \mathbf{v}_i} \cdot d\mathbf{v}_i = \sum_{i=1}^n \frac{d}{dt} \left(\frac{\partial e_{0i}}{\partial \mathbf{v}_i} \right) \cdot d\mathbf{r}_i, \quad (6.2)$$

where we have taken into account (5.2) and the relation

$$\mathbf{u}_i \cdot d\mathbf{r}_i = \mathbf{v}_i \cdot d\mathbf{v}_i, \quad (6.3)$$

which can be proved by dividing both sides by dt .

Substituting (6.1) and (6.2) into the fundamental axiomatic equation (2.16) and dividing by dt , we obtain

$$\sum_{i=1}^n \left[\frac{d}{dt} \left(\frac{\partial e_{0i}}{\partial \mathbf{v}_i} \right) + \frac{\partial U}{\partial \mathbf{r}_i} \right] \cdot \mathbf{v}_i = 0. \quad (6.4)$$

In this equation all n (as a matter of fact, $3n$) expressions in the brackets must be identically equal to zero because otherwise a dependence would exist between the components of the velocities of the different material points, and

this would contradict our sixth axiom which asserts that the time energy of a material point of a system depends only on its own velocity.

Thus from (6.4) we obtain the following system of n vector equations

$$\frac{d}{dt} \left(\frac{\partial e_{oi}}{\partial \mathbf{v}_i} \right) = - \frac{\partial U}{\partial \mathbf{r}_i}, \quad i = 1, 2, \dots, n, \quad (6.5)$$

which are called the **Lagrange equations** and represent the fundamental equations of motion in non-relativistic physics.

Taking into account (5.2), (4.5), and the first relation (4.8), we see that the left side of (6.5) represents the kinetic force f_i of the i th material point. Introducing the notation

$$F_i = - \frac{\partial U}{\partial \mathbf{r}_i} \quad (6.6)$$

and calling F_i the **potential force** which all $n - 1$ material points exert on the i th point, we can write equations (6.5) in the form

$$f_i = F_i, \quad i = 1, 2, \dots, n, \quad (6.7)$$

in which form they are called the **Newton equations** (or **Newton's second law**).

The potential force which the j th material point exerts on the i th point is $F_i^j = - \partial U_{ij} / \partial \mathbf{r}_i$, and the potential force which the i th material point exerts on the j th point is $F_j^i = - \partial U_{ij} / \partial \mathbf{r}_j$, where U_{ij} is the space energy of these two material points. Since U_{ij} depends on the distance between both points, it will be

$$\partial U_{ij} / \partial \mathbf{r}_i = - \partial U_{ij} / \partial \mathbf{r}_j, \quad \text{i.e.,} \quad F_i^j = - F_j^i. \quad (6.8)$$

Thus the potential forces with which two material points of a system (in general, two parts of a system) act on each other are always equal and oppositely directed along the line connecting them. This result is called **Newton's third law**.

Obviously, in equation (6.5) we can write

$$\frac{\partial e_{oi}}{\partial \mathbf{v}_i} = \frac{\partial e_{ki}}{\partial \mathbf{v}_i} = \frac{\partial E_o}{\partial \mathbf{v}_i} = \frac{\partial E_k}{\partial \mathbf{v}_i}, \quad (6.9)$$

where e_{ki} is the kinetic energy of the i th material point and E_k is the kinetic energy of the whole system.

6.2. THE RELATIVISTIC CONSIDERATION

In relativistic physics, equation (6.1) will preserve its form. This is obvious for the electric space energy [see formula (2.9)], since the electric

charges and the distances between them do not depend on the velocities of the charges. However, as can be seen from formulas (2.7) and (5.14), the gravitational space energy becomes velocity dependent in high-velocity physics. The peculiarities of the fundamental equation of motion in gravimagnetism will be considered in §8; in the present general analysis we shall assume that the gravitational charges (the proper masses) are constant, i.e., velocity independent.

In relativistic physics, instead of equation (6.2) we shall have

$$\begin{aligned} dE_o &= \sum_{i=1}^n \frac{\partial E_o}{\partial \mathbf{v}_i} \cdot d\mathbf{v}_i = \sum_{i=1}^n \frac{\partial e_{oi}}{\partial \mathbf{v}_i} \cdot d\mathbf{v}_i = \\ &= \sum_{i=1}^n \frac{d}{dt} \left[\left(1 - \frac{v_i^2}{c^2}\right) \frac{\partial e_{oi}}{\partial \mathbf{v}_i} \right] \cdot d\mathbf{r}_i = \sum_{i=1}^n \frac{d}{dt} \left(\frac{\partial e_i^o}{\partial \mathbf{v}_i} \right) \cdot d\mathbf{r}_i, \end{aligned} \quad (6.10)$$

where e_i^o is the Lagrange time energy of the i th material point.

In relativistic physics, we have to take into account also the space-time energy W . As the space-time energy depends on the distances between the material points and on their velocities, we shall have

$$\begin{aligned} dW &= \sum_{i=1}^n \left(\frac{\partial W}{\partial \mathbf{r}_i} \cdot d\mathbf{r}_i + \frac{\partial W}{\partial \mathbf{v}_i} \cdot d\mathbf{v}_i \right) = \\ &= \sum_{i=1}^n \left[\frac{\partial W}{\partial \mathbf{r}_i} \cdot d\mathbf{r}_i + d \left(\frac{\partial W}{\partial \mathbf{v}_i} \cdot \mathbf{v}_i \right) - d \left(\frac{\partial W}{\partial \mathbf{v}_i} \right) \cdot \mathbf{v}_i \right]. \end{aligned} \quad (6.11)$$

However, it is [see (2.13) and (2.15)]

$$\sum_{i=1}^n d \left(\frac{\partial W}{\partial \mathbf{v}_i} \cdot \mathbf{v}_i \right) = \sum_{i=1}^n dW_i = d \sum_{i=1}^n W_i = 2 dW, \quad (6.12)$$

where W_i is the part of the space-time energy in which the i th material point takes part.

From the last two equations we obtain

$$dW = \sum_{i=1}^n \left[- \frac{\partial W}{\partial \mathbf{r}_i} \cdot d\mathbf{r}_i + d \left(\frac{\partial W}{\partial \mathbf{v}_i} \right) \cdot \mathbf{v}_i \right]. \quad (6.13)$$

Substituting (6.1), (6.10) and (6.13) into the energy conservation law (2.16) and dividing by dt , we obtain by the help of the same reasonings as in §6.1 the fundamental equations of motion in relativistic physics

$$\frac{d}{dt} \left[\frac{\partial (E^o + W)}{\partial \mathbf{v}_i} \right] = - \frac{\partial (U - W)}{\partial \mathbf{r}_i}, \quad i = 1, 2, \dots, n, \quad (6.14)$$

which we call the **full Lagrange equations**.

The quantity

$$\bar{F}_i = - \frac{\partial(U - W)}{\partial \mathbf{r}_i} \quad (6.15)$$

is called the **full potential force** acting on the i th material point.

The **full Newton equations** are

$$\tilde{f}_{oi} \equiv f_{oi} + \frac{d}{dt} \left(\frac{\partial W}{\partial \mathbf{v}_i} \right) = \bar{F}_i \equiv F_i + \frac{\partial W}{\partial \mathbf{r}_i}, \quad i = 1, 2, \dots, n, \quad (6.16)$$

where \tilde{f}_{oi} is called the **full kinetic force** of the i th material point.

The **full Newton's third law** is

$$\frac{\partial(U_{ij} - W_{ij})}{\partial \mathbf{r}_i} = - \frac{\partial(U_{ij} - W_{ij})}{\partial \mathbf{r}_j}, \quad \text{i.e.,} \quad \bar{F}_i^j = - \bar{F}_j^i. \quad (6.17)$$

Using the Lagrange equations and proceeding from the homogeneity of time, homogeneity of space, and isotropy of space, we can easily obtain, respectively, the laws of energy, momentum, and angular momentum conservation in non-relativistic and relativistic physics (the first one representing the assertion of our ninth axiom).

§ 7. FUNDAMENTAL EQUATIONS IN ELECTROMAGNETISM

7.1. THE NEWTON-LORENTZ EQUATION

Let us have a system of n electric charges q_i moving with velocities \mathbf{v}_i , whose distances to a certain space point (called the **reference point**) are r_i . The quantities

$$\Phi = \sum_{i=1}^n \frac{q_i}{\epsilon_0 r_i}, \quad A = \sum_{i=1}^n \mu_0 \frac{q_i \mathbf{v}_i}{c r_i} \quad (7.1)$$

are called, respectively, **electric** and **magnetic potentials** at the reference point. We shall further work in the CGS system of units in which it is assumed $\epsilon_0^{-1} = \mu_0 = 1$.

If at the reference point a material point with mass m , electric charge q , velocity \mathbf{v} , and proper energy e_0 is placed, then the electric and magnetic energies of the whole system of $n + 1$ charges in which this charge q takes part will be

$$U = q \Phi, \quad W = \frac{q}{c} \mathbf{v} \cdot A. \quad (7.2)$$

Putting (7.2) into (6.14), we obtain

$$\frac{d}{dt} \left(p_0 + \frac{q}{c} A \right) = -q \operatorname{grad} \left(\Phi - \frac{\mathbf{v} \cdot \mathbf{A}}{c} \right). \quad (7.3)$$

This is the full Newton equation in electromagnetism and we call it the **Newton-Lorentz equation**.

Since it is

$$\frac{dA}{dt} = \frac{\partial A}{\partial t} + (\mathbf{v} \cdot \operatorname{grad}) A, \quad (7.4)$$

where $(\partial A / \partial t) dt$ is the change of A for a time dt at a given space point and $(\mathbf{v} \cdot \operatorname{grad}) A dt$ is the change of A due to the motion of charge q with velocity \mathbf{v} during this time dt , and taking into account the mathematical relation

$$\operatorname{grad} (\mathbf{v} \cdot \mathbf{A}) = (\mathbf{v} \cdot \operatorname{grad}) \mathbf{A} + (\mathbf{A} \cdot \operatorname{grad}) \mathbf{v} + \mathbf{v} \times \operatorname{rot} \mathbf{A} + \mathbf{A} \times \operatorname{rot} \mathbf{v} \quad (7.5)$$

under the condition $\mathbf{v} = \text{Const}$, we can write the Newton-Lorentz equation in the form

$$\frac{dp_0}{dt} \equiv f_0 = -q \left(\operatorname{grad} \Phi + \frac{1}{c} \frac{\partial \mathbf{A}}{\partial t} \right) + \frac{q}{c} \mathbf{v} \times \operatorname{rot} \mathbf{A}, \quad (7.6)$$

which is commonly called the Lorentz equation. As one can see, the Lorentz equation represents the full Newton equation in electro-magnetism, and we think that it is reasonable to re-name it the Newton-Lorentz equation.

To this equation we always attach its scalar supplement which can be obtained after multiplication of both its sides by the velocity of the charge

$$\frac{de_0}{dt} \equiv \mathbf{v} \cdot \mathbf{f}_0 = -q \mathbf{v} \cdot \left(\operatorname{grad} \Phi + \frac{1}{c} \frac{\partial \mathbf{A}}{\partial t} \right). \quad (7.7)$$

Introducing the quantities

$$\mathbf{E} = -\operatorname{grad} \Phi - \frac{1}{c} \frac{\partial \mathbf{A}}{\partial t}, \quad \mathbf{B} = \operatorname{rot} \mathbf{A}, \quad (7.8)$$

called, respectively, the **electric** and **magnetic intensities**, we can write the Newton-Lorentz equation and its scalar supplement in the form

$$\frac{dp_0}{dt} = q \mathbf{E} + \frac{q}{c} \mathbf{v} \times \mathbf{B}, \quad \frac{de_0}{dt} = q \mathbf{v} \cdot \mathbf{E}. \quad (7.9)$$

Taking partial derivative with respect to time from the electric potential Φ [consider the distances r_i in the expression (7.1) as functions of time] and divergence from the magnetic potential \mathbf{A} , we obtain the following relation

$$\operatorname{div} \mathbf{A} = -\frac{1}{c} \frac{\partial \Phi}{\partial t}. \quad (7.10)$$

This relation is commonly called the « Lorentz condition ». Since in our approach it is a logical result obtained from the axioms, we call it the **equation of potential connection**.

7.2. THE CONNECTION BETWEEN DENSITIES AND POTENTIALS

The **charge** and **current densities** at a given reference point are the following quantities (these are the so-called δ -densities)

$$Q(\mathbf{r}) = \sum_{i=1}^n q_i \delta(\mathbf{r} - \mathbf{r}_i), \quad J(\mathbf{r}) = \sum_{i=1}^n \mathbf{j}_i \delta(\mathbf{r} - \mathbf{r}_i), \quad (7.11)$$

where \mathbf{r} is the radius vector of the reference point, \mathbf{r}_i are the radius vectors of the single charges, and $\delta(\mathbf{r}) = \delta(x) \delta(y) \delta(z)$ is the three-dimensional δ -function of Dirac.

Now we shall establish the differential connection between the charge and current densities and the electric and magnetic potentials.

A. The static and quasi-static cases.

We shall prove the validity of the following mathematical relation

$$\Delta(1/r) = -4\pi\delta(\mathbf{r}), \quad (7.12)$$

where $\Delta = \partial^2/\partial x^2 + \partial^2/\partial y^2 + \partial^2/\partial z^2$ is the Laplace operator and r is the distance between the frame's origin and a space point with radius vector \mathbf{r} .

Indeed, putting into (7.12)

$$r = |\mathbf{r} - \mathbf{0}| = (x^2 + y^2 + z^2)^{1/2}, \quad (7.13)$$

we obtain an identity. Only for $r = 0$ does the left-hand side give the uncertainty $0/0$, and the right-hand side give the uncertainty $\delta(0)$.

To establish whether relation (7.12) is valid also for $r = 0$, let us integrate (7.12) over an arbitrary sphere with radius R which has a centre at the frame's origin. Using the Gauss theorem, we shall obtain for the integral of the left-hand side

$$\int_V \Delta(1/r) dV = \int_V \text{div} [\text{grad}(1/r)] dV = \oint_S \text{grad}(1/r) \cdot dS, \quad (7.14)$$

where S is the surface of the sphere of integration whose volume is V and dS is the elementary area (taken as a vector) of the integrational surface whose direction always points outside from the volume enclosed.

The vector $\text{grad}(1/r) = -\mathbf{r}/r^3$ is directed to the frame's origin, i.e., in a direction opposite to the direction of the vector dS , and thus

$$\int_V \Delta(1/r) dV = - \oint_S \frac{dS}{r^2} = - \frac{1}{R^2} \oint_S dS = -4\pi. \quad (7.15)$$

The integral on the right of (7.12) taken over the same arbitrary sphere, on the grounds of the fundamental property of the δ -function, gives

$$-4\pi \int_V \delta(\mathbf{r}) dV = -4\pi. \quad (7.16)$$

The integrals (7.15) and (7.16) are equal and, since the domains of integration represent spheres with arbitrary radii, both integrands must be also equal. Thus the relation (7.12) is valid also for $r = 0$.

In the same way, or on the grounds of our first axiom for homogeneity and isotropy of space, we can prove the validity of the following relations

$$\Delta(1/|\mathbf{r} - \mathbf{r}_i|) = -4\pi \delta(\mathbf{r} - \mathbf{r}_i), \quad i = 1, 2, \dots, n, \quad (7.17)$$

where \mathbf{r}_i are the radius vectors of n different space points.

Let us now assume that \mathbf{r}_i is the radius vector of a space point where a charge q_i is placed (static case) or where at any moment a charge q_i moving with velocity \mathbf{v}_i can be found (quasi-static case). Multiplying any of the equalities (7.17) by the corresponding electric charge, q_i , or electric current element divided by c , \mathbf{j}_i/c , and summing them, we obtain, after having taken into account (7.1) and (7.11), the following differential connection between potentials and densities for static and quasi-static systems

$$\Delta \Phi = -4\pi Q, \quad \Delta A = -\frac{4\pi}{c} \mathbf{J}. \quad (7.18)$$

B. The dynamic case.

Let us consider a point (calling it the i -point) which moves at velocity \mathbf{v} along the x -axis of a rest frame K and at the initial zero moment $t = 0$ crosses the frame's origin. Let a moving frame K' be attached to this i -point and the transformation between K and K' be a special one. In such a case the radius vector of the i -point in K' will be $\mathbf{r}'_i = (0,0,0)$.

If the radius vector of a reference point in frame K is $\mathbf{r} = (x,y,z)$, then, according to the Marinov transformation (3.34), the radius vector \mathbf{r}' of the same reference point in the moving frame K' will be

$$\mathbf{r}' = (x', y', z') = \left[\frac{x - vt}{(1 - v^2/c^2)^{1/2}}, y, z \right]. \quad (7.19)$$

The distance between the i -point and the reference point considered in frame K' but expressed through the coordinates in frame K will be

$$r_o = |\mathbf{r}' - \mathbf{r}'_i| = |\mathbf{r} - \mathbf{r}_i|_o = \left[\frac{(x - vt)^2 + (1 - v^2/c^2)(y^2 + z^2)}{1 - v^2/c^2} \right]^{1/2} \quad (7.20)$$

This distance considered in frame K and expressed through the coordinates in frame K will be

$$r = |\mathbf{r} - \mathbf{r}_i| = [(x - vt)^2 + y^2 + z^2]^{1/2}. \quad (7.21)$$

We call r the **distance** and r_o the **proper distance** and we have considered them in detail in Marinov (1975a). The difference between these two distances, as already said in §3.3, is due to the aether-Marinov character of light propagation and this has nothing to do with a physical length contraction (with the so-called « Lorentz contraction »). As a matter of fact, here we are considering the distance between two points *moving with respect to one another* which cannot be connected by a rigid rod and thus it is senseless to speak about contraction of such a rod.

The validity of the following mathematical relation can now easily be proved

$$\Delta (1/r_o) = -4\pi \delta(\mathbf{r} - \mathbf{r}_i). \quad (7.22)$$

where $\Delta = \partial^2/\partial x^2 + \partial^2/\partial y^2 + \partial^2/\partial z^2 - \partial^2/c^2 \partial t^2$ is the d'Alembert operator and $r_o = |\mathbf{r} - \mathbf{r}_i|_o$ is the proper distance between a space point with radius vector $\mathbf{r} = (x, y, z)$ and a moving point with a radius vector $\mathbf{r}_i = (vt, 0, 0)$.

Indeed, putting into (7.22) the expression (7.20) for r_o , we obtain an identity. Only for $r_o = 0$, i.e., for

$$x - vt = 0, \quad y = 0, \quad z = 0, \quad (7.23)$$

does the left-hand side give the uncertainty $0/0$, and the right-hand side the uncertainty $\delta(0)$.

To establish whether relation (7.22) is valid also for $r_o = 0$ let us integrate (7.22) over an arbitrary sphere with radius R which has a centre at the point whose coordinates are given by (7.23)

$$\int_V \Delta (1/r_o) dV = -4\pi \int_V \delta(\mathbf{r} - \mathbf{r}_i) dV. \quad (7.24)$$

For all points of the volume V the integrand on the left-hand side is equal to zero. Thus we can spread the integral over a small domain around the point with coordinates given by (7.23), i.e., around the frame's origin of K' . But at $r_o \rightarrow 0$ it is $1/r_o \rightarrow \infty$, and the derivatives with respect to x, y, z will

increase much faster than the derivative with respect to t . Hence the last one can be neglected with respect to the first ones. So we reduce the integral on the left-hand side of (7.24) to the integral (7.15) which gives -4π . The integral on the right-hand side of (7.24), on the grounds of the fundamental property of the δ -function, gives the same result, and, as in §7.2A, we conclude that the integrands must be equal. Thus the relation (7.22) is valid also for the case (7.23).

In the same manner as in §7.2A, from the relation (7.22) we can obtain the following connection between potentials and densities for the most general dynamic case

$$\Delta \Phi = -4\pi Q(t), \quad \Delta A = -\frac{4\pi}{c} J(t), \quad (7.25)$$

where the densities $Q(t)$ and $J(t)$ are functions of time.

7.3. THE MAXWELL-LORENTZ EQUATIONS

Taking rotation from both sides of the first equation (7.8) and divergence from both sides of the second equation (7.8) and making use of the following mathematical relations

$$\text{rot}(\text{grad } \Phi) = 0, \quad \text{div}(\text{rot } A) = 0. \quad (7.26)$$

we obtain the **first pair of the Maxwell-Lorentz equations**

$$\text{rot } E = -\frac{1}{c} \frac{\partial B}{\partial t}, \quad \text{div } B = 0. \quad (7.27)$$

Let us now take partial derivatives with respect to time from both sides of the first equation (7.8), dividing it by c ,

$$\frac{1}{c} \frac{\partial E}{\partial t} = -\frac{1}{c} \text{grad} \frac{\partial \Phi}{\partial t} - \frac{1}{c^2} \frac{\partial^2 A}{\partial t^2}. \quad (7.28)$$

Write the second equation (7.25) in the form

$$-\frac{1}{c^2} \frac{\partial^2 A}{\partial t^2} = -\Delta A - \frac{4\pi}{c} J \quad (7.29)$$

and put here the mathematical relation

$$\Delta A = \text{grad}(\text{div } A) - \text{rot}(\text{rot } A). \quad (7.30)$$

Putting (7.29) into (7.28) and taking into account (7.10), we obtain

$$\text{rot } B = \frac{1}{c} \frac{\partial E}{\partial t} + \frac{4\pi}{c} J. \quad (7.31)$$

Let us now take divergence from both sides of the first equation (7.8)

$$\operatorname{div} \mathbf{E} = -\Delta \Phi - \frac{1}{c} \frac{\partial}{\partial t} (\operatorname{div} \mathbf{A}). \quad (7.32)$$

Write the first equation (7.25) in the form

$$\Delta \Phi = \frac{1}{c^2} \frac{\partial^2 \Phi}{\partial t^2} - 4\pi Q. \quad (7.33)$$

Putting (7.33) into (7.32) and taking into account (7.10), we obtain

$$\operatorname{div} \mathbf{E} = 4\pi Q. \quad (7.34)$$

Equations (7.31) and (7.34) represent the **second pair of the Maxwell-Lorentz equations**.

§ 8. FUNDAMENTAL EQUATIONS IN GRAVIMAGRETISM

8.1. THE NEWTON-MARINOV EQUATION

In §6.2 we pointed out that the gravitational energy in high-velocity physics is velocity dependent. Thus in relativistic gravitation instead of equation (6.1) we shall have

$$dU_\kappa = \sum_{i=1}^n \left(\frac{\partial U_\kappa}{\partial \mathbf{r}_i} \cdot d\mathbf{r}_i + \frac{\partial U_\kappa}{\partial \mathbf{v}_i} \cdot d\mathbf{v}_i \right) = \sum_{i=1}^n \left[\frac{\partial U_\kappa}{\partial \mathbf{r}_i} \cdot d\mathbf{r}_i + \left(\frac{\partial U_\kappa}{\partial \mathbf{v}_i} \cdot d\mathbf{v}_i \right) \frac{\mathbf{v}_i \cdot \mathbf{v}_i}{v_i^2} \right]. \quad (8.1)$$

Space-time energy is very small with respect to space energy (the space-time energy of two material points moving with velocities $\mathbf{v}_1, \mathbf{v}_2$ represents a $\mathbf{v}_1 \cdot \mathbf{v}_2/c^2$ part of their space energy), and we can consider the gravitational charges (the proper masses) in the magnetic energy as constants. Thus we can assume that the differential of the space-time energy in gravimagnetism is given by formula (6.13).

Putting (8.1), (6.10) and (6.13) into the energy conservation law (2.16), we obtain by the help of the same reasonings as in §6.1 the fundamental equations of motion in gravimagnetism

$$\frac{d}{dt} \left[\frac{\partial (E^\circ + W_\kappa)}{\partial \mathbf{v}_i} \right] + \left(\frac{\partial U_\kappa}{\partial \mathbf{v}_i} \cdot \mathbf{u}_i \right) \frac{\mathbf{v}_i}{v_i^2} = - \frac{\partial (U_\kappa - W_\kappa)}{\partial \mathbf{r}_i}, \quad i = 1, 2, \dots, n, \quad (8.2)$$

where \mathbf{u}_i is the acceleration of the i th material point.

As it can be seen from formulas (2.7) and (5.14), the quantity $\partial U_{\kappa} / \partial \mathbf{v}$, has the direction of the vector \mathbf{v}_i . In gravitation, as a rule, motions with large tangential accelerations cannot be realized and, assuming $(\partial U_{\kappa} / \partial \mathbf{v}_i) \cdot \mathbf{u}_i = 0$, we can write the fundamental equations of motion in gravimagnetism in the general form (6.14).

Let us consider a system of n masses m_i moving with velocities \mathbf{v}_i and having proper masses m_{oi} . Introduce the **gravitational and magnetic potentials**

$$\Phi_{\kappa} = - \sum_{i=1}^n \gamma \frac{m_{oi}}{r_i}, \quad A_{\kappa} = - \sum_{i=1}^n \gamma \frac{m_{oi} \mathbf{v}_i}{c r_i}, \quad (8.3)$$

where r_i are the distances to a certain reference point where a mass m moving with velocity \mathbf{v} and having proper mass m_o is placed.

The gravitational and magnetic energies of the whole system of $n+1$ masses in which mass m takes part will be

$$U_{\kappa} = m_o \Phi_{\kappa}, \quad W_{\kappa} = \frac{m_o}{c} \mathbf{v} \cdot A_{\kappa}. \quad (8.4)$$

Putting (8.4) into the full Lagrange (full Newton) equation (6.14), we obtain the **Newton-Marinov equation**

$$\frac{d\mathbf{p}_o}{dt} \equiv \mathbf{f}_o = - m_o (\text{grad } \Phi_{\kappa} + \frac{1}{c} \frac{\partial A_{\kappa}}{\partial t}) + \frac{m_o}{c} \mathbf{v} \times \text{rot} A_{\kappa} \quad (8.5)$$

and its scalar supplement

$$\frac{de_o}{dt} \equiv \mathbf{v} \cdot \mathbf{f}_o = - m_o \mathbf{v} \cdot (\text{grad } \Phi_{\kappa} + \frac{1}{c} \frac{\partial A_{\kappa}}{\partial t}). \quad (8.6)$$

Introducing the quantities

$$\mathbf{G} = - \text{grad } \Phi_{\kappa} - \frac{1}{c} \frac{\partial A_{\kappa}}{\partial t}, \quad \mathbf{B}_{\kappa} = \text{rot} A_{\kappa}, \quad (8.7)$$

called, respectively, the **gravitational and magnetic intensities**, we can write the Newton-Marinov equation and its scalar supplement in the form

$$\frac{d\mathbf{p}_o}{dt} = m_o \mathbf{G} + \frac{m_o}{c} \mathbf{v} \times \mathbf{B}_{\kappa}, \quad \frac{de_o}{dt} = m_o \mathbf{v} \cdot \mathbf{G}. \quad (8.8)$$

The equation of potential connection is

$$\text{div} A_{\kappa} = - \frac{1}{c} \frac{\partial \Phi_{\kappa}}{\partial t}. \quad (8.9)$$

Introducing the proper mass and proper momentum densities (these are the so-called δ -densities)

$$\mu_o(\mathbf{r}) = \sum_{i=1}^n m_{oi} \delta(\mathbf{r} - \mathbf{r}_i), \quad \vec{\pi}_o(\mathbf{r}) = \sum_{i=1}^n \mathbf{p}_{oi} \delta(\mathbf{r} - \mathbf{r}_i), \quad (8.10)$$

we can establish in the same manner as in §7.2 the following relation between these densities and the gravimagnetic potentials for the most general dynamic case

$$\Delta \Phi_\kappa = 4\pi\gamma\mu_o(t), \quad \Delta \mathbf{A}_\kappa = \frac{4\pi}{c} \gamma \vec{\pi}_o(t). \quad (8.11)$$

We wish to emphasize that equations (7.25), as well as equations (7.18), are written at the assumption that we are working in the CGS system of units, where $1/\epsilon_o = \mu_o = 1$ (see the beginning of §7.1).

8.2. THE MAXWELL-MARINOV EQUATIONS

In the same manner as in §7.3 we can obtain the **first** and **second** pairs of the **Maxwell-Marinov equations**

$$\text{rot } \mathbf{G} = -\frac{1}{c} \frac{\partial \mathbf{B}_\kappa}{\partial t}, \quad \text{div } \mathbf{B}_\kappa = 0, \quad (8.12)$$

$$\text{rot } \mathbf{B}_\kappa = \frac{1}{c} \frac{\partial \mathbf{G}}{\partial t} - \frac{4\pi}{c} \gamma \vec{\pi}_o, \quad \text{div } \mathbf{G} = -4\pi\gamma\mu_o, \quad (8.13)$$

whose analogues in electromagnetism are the Maxwell-Lorentz equations.

8.3. REDUCED CHARGES AND MASSES

If we take a general look at the fundamental equations of electromagnetism and gravimagnetism, we shall establish that it is more reasonable to work with the **reduced electric charges** and **reduced masses**,

$$q_c = q/c, \quad m_c = m/c, \quad (8.14)$$

instead of the electric charges, q , and masses, m .

With the reduced charges and masses the space and space-time energies of two material points will be written

$$U_e = \frac{1}{\epsilon_o} \frac{q_{c1} q_{c2}}{r} c^2, \quad W_e = \mu_o \frac{q_{c1} q_{c2}}{r} \mathbf{v}_1 \cdot \mathbf{v}_2, \quad (8.15)$$

$$U_\kappa = -\gamma \frac{m_{c01} m_{c02}}{r} c^2, \quad W_\kappa = -\gamma \frac{m_{c01} m_{c02}}{r} \mathbf{v}_1 \cdot \mathbf{v}_2. \quad (8.16)$$

All equations in electromagnetism and gravimagnetism will obtain more symmetric forms when the reduced charges and masses are used. For example, the Newton-Lorentz equation (7.9) will be written as follows [see (5.13)]

$$\frac{d\mathbf{p}_0}{dt} = q_c (c \mathbf{E} + \mathbf{v} \times \mathbf{B}), \quad \frac{d\tilde{p}_0}{dt} = q_c \mathbf{v} \cdot \mathbf{E}. \quad (8.17)$$

It is important to note that universal constants are not the charge of the electron and the mass of the electron but their reduced values (see §12).

We have considered the fundamental electromagnetic equations in Marinov (1978a) and the fundamental gravimagnetic equations in Marinov (1978b). In Marinov (1978b) we give a detailed analysis of the so-called « Mercury problem ».

§ 9. PARTICLES AND WAVES

In our third axiom, we introduced the quantity T , called the period of the material point, according to relation (2.5).

The quantity

$$\nu = 1/T \quad (9.1)$$

is called the **frequency** of the material point considered. Thus we shall have [see (2.5) and (5.8)]

$$e_0 \equiv \frac{m c^2}{(1 - v^2/c^2)^{1/2}} = h \nu. \quad (9.2)$$

Multiplying both sides of this equation by the velocity \mathbf{v} of the material point, we obtain [see (4.2)]

$$m \mathbf{v}_0 = \frac{h \nu}{c^2} \mathbf{v}. \quad (9.3)$$

The quantity

$$\kappa = \nu v/c^2 \quad (9.4)$$

is called the **wave number** of the material point m .

Write equation (9.3) in the form

$$m \mathbf{v}_0 = h \kappa \mathbf{n}, \quad (9.5)$$

where \mathbf{n} is the unit vector directed along the velocity of the material point.

The vector quantity

$$\vec{k} = \hbar \mathbf{n} = \frac{\nu}{c^2} \nu \mathbf{n} = \frac{\nu}{c^2} \mathbf{v} \quad (9.6)$$

is called the **wave vector** of the material point.

The quantity

$$\lambda = 1/k = c^2/\nu v \quad (9.7)$$

is called the **wavelength** of the material point.

If the material point considered is a photon, then $\nu = c$, and we have

$$\nu \lambda = c. \quad (9.8)$$

The quantities ν_r , T_r defined by the relation

$$\nu_r = 1/T_r = m c^2/h \quad (9.9)$$

are called the **rest frequency** and **rest period** of the material point and are equal to ν and T , respectively, for $\nu = 0$. Obviously the **rest wave number** of any material point, \vec{k}_r , is equal to zero and the **rest wavelength**, λ_r , is infinitely large.

Formulas (9.5) and (9.2) can be written [see (4.4)] :

a) with the help of the frequency

$$\vec{p}_0 = \frac{h \nu}{c^2} \mathbf{v}, \quad e_0 = h \nu, \quad (9.10)$$

b) with the help of the wavelength

$$\vec{p}_0 = \frac{h}{\lambda} \mathbf{n}, \quad e_0 = \frac{h c^2}{\lambda \nu}. \quad (9.11)$$

These formulas are called **de Broglie's relations**.

The quantities m , \vec{p}_0 , e_0 describe the « particle » character of the material points and the quantities T , ν , \vec{k} , λ describe their « wave » character.

As we said at the end of §5.2, the dialectic unity of opposites which the ideas of particles and waves offer is still not lucidly enough resolved. We have the feeling that this contradiction will never be understood with such clarity as, for example, high-velocity physics will be understood after the acceptance of our absolute space-time theory. Nevertheless, in classical (non-quantum) physics, i.e., where, according to our categorization, the phenomenon interference is not considered, the « particles-waves » contradiction does not originate logical difficulties, as the reader can see on reading this book.

§ 10. FREQUENCY AND WAVELENGTH SHIFTS OF LIGHT

10.1. KINEMATIC SHIFT (THE DOPPLER EFFECT)

The **light Doppler effect** is the difference between the frequency and wavelength with which a photon is emitted from a source of radiation and those measured by an observer, due to the motion of source and observer with respect to absolute space; we call this effect also the **kinematic frequency and wavelength shifts of light**, and we have considered it in Marinov (1978e). A review of the theoretical part of this paper is given in this sub-section.

A. Source and observer at rest.

Let us suppose that there is a source (emitter) of photons which rests in absolute space. The frequency ν registered by an observer (receiver) who is also at rest in absolute space and the wavelength λ , which he can measure, are called **emitted frequency** and **emitted wavelength**. The relation between them is given by formula (9.8).

B. Source moving, observer at rest.

Let us now suppose (fig. 10-1) that the observer is at rest in absolute space at the point O' and the light source moves with velocity v from the

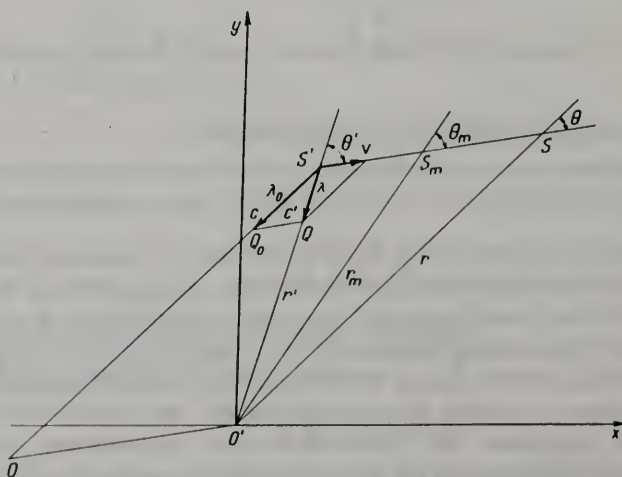

Fig. 10-1

position S' where a photon is emitted to the position S where the source will be at the moment when the photon will be received by the observer. We shall suppose that the wavelength of the interchanged photon is much less than the distance between source and observer and, thus, the **emission and reception positions** of the source can be considered as points.

The source will be at the **middle position** S_m at the **middle moment** between the **emission and reception moments**. θ' is called the **emission angle**, θ the **reception angle** and θ_m the **middle angle**. We must note that when defining these angles a certain freedom is inevitable which leads to certain differences in the notations and in the formulas from those of our earlier papers (Marinov, 1970, 1972a, 1973). Now, once and for all, we make the following stipulation : The emission, reception and middle angles are subtended by the velocity of the moving object and the line connecting the object at rest with the moving object at the emission, reception and middle moments, respectively. We attach the subscript « o » to the received (observed) frequency and wavelength and not to the emitted which will be written without any subscript. The upperscript « $'$ » will be attached to the emission distance, position and angle, while the reception distance, position and angle will be written without any upperscript.

When the source is moving, the observer at rest will not register the frequency ν and will not measure the wavelength λ which are to be registered and measured if the source be at rest and which we have called the emitted frequency and wavelength, but some other, in general, different quantities, ν_o, λ_o , which we call the **observed (or received) frequency and wavelength**.

If in fig. 10-1 we present the emitted wavelength by the segment $S'Q$, then, proceeding from our third axiom in which the « burst » model of the material points is postulated, we have to present the observed wavelength λ_o by the segment $S'Q_o$ (as a matter of fact, by that segment equal and parallel to $S'Q$, whose final point is Q). We repeat that we consider the case where the distance between source and observer is much greater than the wavelength of the photon (we have enlarged the wavelength diagram for clarity).

Since the photon moves in absolute space with velocity c , we have

$$\nu_o \lambda_o = c . \quad (10.1)$$

From (9.8) and (10.1) we obtain

$$\nu_o / \nu = \lambda / \lambda_o . \quad (10.2)$$

The triangles $S'Q_oQ$ and $O'SS'$ are similar and thus

$$\lambda / \lambda_o = r' / r . \quad (10.3)$$

On the other hand, if we should suppose that the source is at rest and the observer moving from the emission position O' to the reception position O , we obtain from the similar triangles $S'Q_0Q$ and $S'O'O'$

$$r'/r = c'/c, \quad (10.4)$$

since the segments $S'Q_0$ and $S'Q$ are, respectively, *proportional* to the absolute light velocity c (i.e., to the velocity of light with respect to absolute space) and to the relative light velocity c' (i.e., to the velocity of light with respect to the moving observer), both measured on an absolute clock.

From the last three relations, using formulas (3.31) in which we write $V = v$, we obtain

$$v_o = v \frac{(1 - v^2/c^2)^{1/2}}{1 + v \cos \theta'/c} = v \frac{1 - v \cos \theta/c}{(1 - v^2/c^2)^{1/2}}, \quad (10.5)$$

$$\lambda_o = \lambda \frac{1 + v \cos \theta'/c}{(1 - v^2/c^2)^{1/2}} = \lambda \frac{(1 - v^2/c^2)^{1/2}}{1 - v \cos \theta/c}. \quad (10.6)$$

Formulas (10.6) can be obtained *directly* from (10.3) [and then formulas (10.5) from (10.2) and (10.6)] if we should use formulas (4.21) obtained in Marinov (1975a), which give the relation between the **emission** and **reception distances** and where, following our present notation, we have to write $r_o = r'$, $\theta_o = \theta'$, thus obtaining

$$r = r' \frac{1 + v \cos \theta'/c}{(1 - v^2/c^2)^{1/2}} = r' \frac{(1 - v^2/c^2)^{1/2}}{1 - v \cos \theta/c}. \quad (10.7)$$

Multiplying, on one hand, both formulas (10.5) and, on the other hand, both formulas (10.6), squaring them and writing $\cos \theta' = \cos \theta_m + a$, $\cos \theta = \cos \theta_m - a$, where a is an algebraic quantity, we obtain within the necessary accuracy

$$v_o = v \left(\frac{1 - v \cos \theta_m/c}{1 + v \cos \theta_m/c} \right)^{1/2}, \quad \lambda_o = \lambda \left(\frac{1 + v \cos \theta_m/c}{1 - v \cos \theta_m/c} \right)^{1/2}. \quad (10.8)$$

For $\theta' = \theta = \theta_m = 0$ (or π), we call the Doppler effect **longitudinal**.

For $\theta' = \pi/2$, $\theta = \pi/2 - v/c$, $\theta_m = \pi/2 - v/2c$, we call the Doppler effect **post-traverse**.

For $\theta = \pi/2$, $\theta' = \pi/2 + v/c$, $\theta_m = \pi/2 + v/2c$, we call the Doppler effect **ante-traverse**.

For $\theta_m = \pi/2$, $\theta' = \pi/2 + v/2c$, $\theta = \pi/2 - v/2c$, we call the Doppler effect **traverse**.

The post-traverse, ante-traverse and traverse Doppler effects are called by the common name, **transverse Doppler effect**.

C. Source at rest, observer moving.

Let us now suppose (see again fig. 10-1) that the source is at rest in absolute space at the point S' and the observer moves with velocity v from the emission position O' to the reception position O .

Since the photon proceeds with respect to the moving observer with the relative velocity c' , the relation between the observed frequency and wavelength will be

$$v_o \lambda_o = c'. \quad (10.9)$$

According to our « burst » model for the photons, their wavelength can change only when the source moves with respect to absolute space. The motion of the observer with respect to absolute space leads only to a change in the velocity and frequency of the observed photons but *not* to a change in their wavelengths. We must emphasize that the wavelength is to be measured *always* with respect to absolute space, *even in the case of a moving observer*. We have to stress also that a direct measurement of the wavelength cannot be performed. One can measure directly only the wavelength of standing waves, i.e., of « to and fro » propagating photons which interfere (see §31). All measurements of the wavelength of uni-directionally propagating photons are indirect (see §32). If one should accept that the motion of the observer leads to a change in the wavelength, then one is impelled to accept Einstein's dogma about the constancy of light velocity in any inertial frame which, as we have experimentally shown, does not correspond to physical reality.

Thus for our case of source at rest and moving observer, we have

$$\lambda_o = \lambda. \quad (10.10)$$

From (9.8), (10.9) and (10.10) we obtain

$$v_o/v = c'/c. \quad (10.11)$$

Making use of formulas (3.31) in which we write $V = v$, we obtain

$$v_o = v \frac{(1 - v^2/c^2)^{1/2}}{1 + v \cos \theta'/c} = v \frac{1 - v \cos \theta/c}{(1 - v^2/c^2)^{1/2}}. \quad (10.12)$$

Here again a formula analogical to the first formula (10.8) can be introduced, as well as the definitions for longitudinal and transverse Doppler effects.

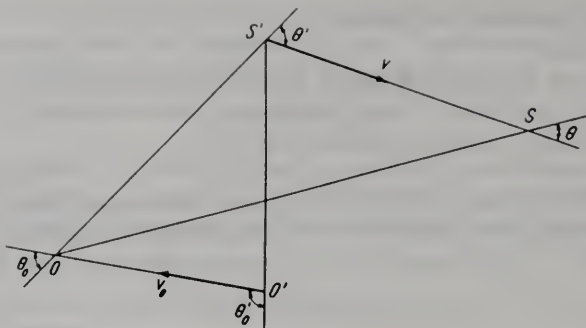

Fig. 10-2

D. Source and observer moving.

Now suppose (fig. 10-2) that the source moves with velocity v with respect to absolute space and the observer with velocity v_o , so that S', O' are the emission positions of source and observer and S, O are their reception positions.

We introduce two pairs of emission and reception angles : θ'_o and θ_o are the emission and reception angles if the source were at rest at its emission position, while θ' and θ are the emission and reception angles if the observer were at rest at its reception position. For certain problems it is convenient to use the angles θ', θ_o , while for others the angles θ'_o, θ .

To find the relation between the emitted and received frequencies and wavelengths, we proceed as follows : Let us suppose that the real source emits a photon and an imaginary observer is at rest at point O (the reception position of the real observer). The frequency and wavelength registered by him, called intermediary, will be [use the first and second formulas (10.5) and (10.6)]

$$\nu_{int} = \nu \frac{(1 - v^2/c^2)^{1/2}}{1 + v \cos \theta'/c} = \nu \frac{1 - v \cos \theta/c}{(1 - v^2/c^2)^{1/2}}, \quad (10.13)$$

$$\lambda_{int} = \lambda \frac{1 + v \cos \theta'/c}{(1 - v^2/c^2)^{1/2}} = \lambda \frac{(1 - v^2/c^2)^{1/2}}{1 - v \cos \theta/c}. \quad (10.14)$$

If now an imaginary source is at rest at point S' (the emission position of the real source) and emits a photon with frequency ν_{int} and wavelength λ_{int} , then the frequency and wavelength registered by the real observer when he crosses point O will be [use formulas (10.12) and (10.10)]

$$\nu_o = \nu_{int} \frac{(1 - v_o^2/c^2)^{1/2}}{1 + v_o \cos \theta_o'/c} = \nu_{int} \frac{1 - v_o \cos \theta/c}{(1 - v_o^2/c^2)^{1/2}}, \quad (10.15)$$

$$\lambda_o^\circ = \lambda_{int}. \quad (10.16)$$

Putting (10.13) and (10.14) into (10.15) and (10.16), we obtain

$$\begin{aligned} \nu_o &= \nu \frac{1 - v_o \cos \theta_o'/c}{1 + v \cos \theta'/c} \left(\frac{1 - v^2/c^2}{1 - v_o^2/c^2} \right)^{1/2} = \\ &= \nu \frac{1 - v \cos \theta/c}{1 + v_o \cos \theta_o'/c} \left(\frac{1 - v_o^2/c^2}{1 - v^2/c^2} \right)^{1/2}, \end{aligned} \quad (10.17)$$

$$\lambda_o^\circ = \lambda \frac{1 + v \cos \theta'/c}{(1 - v^2/c^2)^{1/2}} = \lambda \frac{(1 - v^2/c^2)^{1/2}}{1 - v \cos \theta/c}. \quad (10.18)$$

When $v_o = v$, then $\theta_o = \pi - \theta'$, $\theta_o' = \pi - \theta$, and formulas (10.17) reduce to

$$\nu_o = \nu, \quad (10.19)$$

while formulas (10.18) remain the same, and

$$\nu_o \lambda_o^\circ = c', \quad (10.20)$$

c' being the relative light velocity with respect to source and observer. In this case θ is the angle between the opposite line of light propagation and the velocity of source and observer registered with respect to both of them, while θ' is the same angle registered with respect to absolute space.

In formula (10.19), ν is the frequency of the photons emitted by the source moving at velocity v and, thus, λ in the corresponding formulas (10.18) is the emitted wavelength of such photons. If the same source should remain at rest in absolute space (remember that only when the source is at rest in absolute space can an observer, also at rest, measure the emitted frequency and wavelength), the period of the emitted photons will become shorter (and the frequency higher) because of the absolute time dilation; thus the emitted wavelength λ of such photons will become shorter [by the factor $(1 - v^2/c^2)^{1/2}$], so that instead of (10.18) we have to write

$$\lambda_o = \lambda \frac{1 + v \cos \theta'/c}{1 - v^2/c^2} = \frac{\lambda}{1 - v \cos \theta/c}, \quad (10.21)$$

and now

$$\nu_o \lambda_o = c'_o, \quad (10.22)$$

c'_o being the proper relative light velocity with respect to source and observer.

Formula (10.19) shows that if an observer moves with the same velocity as the light source, then the measurement of the received frequency can *never* give information about their absolute velocity. However, formula (10.21) shows that the measurement of the wavelength can give such information. These conclusions are of extreme importance. Let us note that, according to contemporary physics which proceeds from the principle of relativity, a Doppler effect appears only when source and observer move with respect to one another. In contradistinction to this conclusion, we have shown that a Doppler effect appears also when source and observer move with the same velocity, namely, the received wavelength is different from that which should be measured if source and observer be at rest in absolute space (see §32).

10.2 DYNAMIC SHIFT (THE EINSTEIN EFFECT)

The **light Einstein effect** is the difference between the frequency and wavelength with which a photon is emitted from a source of radiation and those measured by an observer due to the different gravitational potentials at the points where source and observer are placed; we call this effect also the **dynamic (or gravitational) frequency and wavelength shifts of light** and we have considered it in Marinov (1976a). A review of this paper is given in this sub-section.

Let us have a mass M which is at rest in absolute space and a mass m ($m \ll M$) which moves with velocity v in the gravitational field of mass M . The gravitational energy of these two masses will be [see formulas (2.7) and (5.14)]

$$U_g = -\gamma \frac{m M}{r(1 - v^2/c^2)^{1/2}}. \quad (10.23)$$

According to the ninth axiom we have for this case

$$de_o/dt = -dU_g/dt. \quad (10.24)$$

Putting here (5.8) and (10.23), taking into account (9.2) and supposing that the material point is a photon (i.e., supposing $m = 0$, $v = c$), we obtain after the integration of (10.24)

$$\nu_o^o - \nu = \frac{\gamma M}{c^2} \left(\frac{\nu_o^o}{r_o} - \frac{\nu}{r} \right) = -\frac{1}{c^2} (\nu_o^o \Phi_o - \nu \Phi), \quad (10.25)$$

or

$$\nu_o^o = \nu \frac{1 + \Phi/c^2}{1 + \Phi_o/c^2} \cong \nu [1 + (\Phi - \Phi_o)/c^2], \quad (10.26)$$

where

$$\Phi = -\gamma \frac{M}{r}, \quad \Phi_0 = -\gamma \frac{M}{r_0} \quad (10.27)$$

are the gravitational potentials caused by mass M , respectively, at the point of emission of the photon whose distance from mass M is r and at the point of reception (observation) of the photon whose distance from mass M is r_0 (we consider M as a point mass or as a homogeneous sphere).

Formula (10.26) is the formula for the gravitational (dynamic) frequency shift. We must emphasize that the period T and the frequency ν of the emitted photon are measured on a clock (imagine a light clock) which is placed in the region where the photon is emitted (i.e., where the gravitational potential is Φ), while the period T_0 and the frequency ν_0 of the received photon are measured on a clock placed in the region where the photon is received (i.e., where the gravitational potential is Φ_0). Thus the subscript « 0 » of the period and frequency signifies « observed » and the superscript « ° » signifies that time is measured on a clock placed in a region with gravitational potential Φ_0 .

Now we shall find the formula for the gravitational wavelength shift. Since according to our tenth axiom the photons move with velocity c in absolute space when this velocity is measured by the help of a nearby light clock, independent of the local concentration of matter, i.e., independent of the gravitational potential in the space region considered, we shall have

$$\nu \lambda = c, \quad \nu_0 \lambda_0 = c, \quad (10.28)$$

where λ is the wavelength of the emitted photon and λ_0 is the wavelength of the observed photon.

From (10.16) and (10.28) we obtain

$$\lambda_0 = \lambda \frac{1 + \Phi_0/c^2}{1 + \Phi/c^2}. \quad (10.29)$$

The physical quantity frequency (respectively, period) is a relatively more complicated notion than the physical quantity wavelength because the frequency is measured by the help of clocks which have different rates in dependence on their velocities in absolute space (as we have seen in §2.4 and shall further see in §11.1) and on the gravitational potentials (as we shall see in §11.2), while the wavelength is measured by the help of rigid rods whose lengths depend neither on their velocities nor on the gravitational potentials. Hence, formula (10.29) clearly shows that the wavelength of a photon which crosses a region with a stronger gravitational potential will have in that region a smaller length. This gravitational potential, whose *absolute value* is greater, is stronger. Thus, if $|\Phi_0| > |\Phi|$, then $\lambda_0 < \lambda$.

The problem about the relation between the frequencies (the periods) of the photons is considered in more detail in §11.2.

§11. TIME DILATION

11.1. KINEMATIC (LORENTZ) TIME DILATION

In §2.4 we have shown that the period of any light clock increases when its absolute velocity increases. According to the Newtonian conceptions this effect is different for a « transverse » and « longitudinal » light clock, the « arm » of the first being perpendicular and of the second parallel to the clock's velocity. According to our absolute space-time theory, this effect is the same for any orientation of the clock's « arm », being given by formula (3.18) and is called the **kinematic time dilation**.

Proceeding from formula (3.31), we can easily show that formula (3.18) is valid for any orientation of the light clock's « arm ». Indeed, if the « arm » of the light clock is d , its absolute velocity v , and the angle between them θ' , then the clock's period, if measured in absolute time, is

$$\begin{aligned} T_0 &= \frac{d}{c'^+} + \frac{d}{c'^-} = \frac{d}{c} \frac{1 + v \cos \theta'^+ / c}{(1 - v^2/c^2)^{1/2}} + \frac{d}{c} \frac{1 + v \cos \theta'^- / c}{(1 - v^2/c^2)^{1/2}} = \\ &= \frac{2d}{c(1 - v^2/c^2)^{1/2}} = \frac{T}{(1 - v^2/c^2)^{1/2}}, \end{aligned} \quad (11.1)$$

where $T = 2d/c$ is the period of the same clock when being at rest. θ'^+ and θ'^- are the angles (for the « there » and « back » trips) between the velocity of the clock, v , and the relative light velocity, c' , i.e., the angles subtended by the direction of clock's propagation and the directions of light propagation, measured with respect to the moving clock. Thus it is $\theta'^+ = \theta'$, $\theta'^- = \pi - \theta'$.

Let us note that the angles θ^+ and θ^- (for the « there » and « back » trips) between v and c , i.e., the angles subtended by the direction of clock's propagation and the directions of light propagation, measured with respect to absolute space, are, in general, not complementary.

The result (11.1) can be also obtained proceeding from formula (10.7) and calculating the path with respect to absolute space which the light pulse has to cover during its « there » and « back » trips.

As stated in §3.3, the experiment has shown that also the periods of other physical systems are influenced by the kinematic time dilation, but the problem whether this phenomenon can be generalized for the period of any

material system remains open. At any rate, we can be sure that if the period of a system is determined by the motion of mass-less particles (i.e., particles with $m = 0$), then this period will be influenced by the kinematic time dilation. Consider, for example, an aerial which emits radio waves. The period (frequency) of the radio waves will be determined by the time in which the potential of the antenna's top passes through two successive maxima, and this is determined by the time in which light crosses the antenna's « arm ».

Larmor (1900) was the first to introduce time dilation and rightly considered it as an absolute effect. Einstein (1905) analysed this phenomenon five years later and wrongly considered it as a relative effect. Lorentz treated time dilation in many publications also from an absolute point of view; since this effect follows logically from the transformation to which his name is attributed, we think that the kinematic time dilation should be called the **Lorentz time dilation**.

Time dilation is one of the most controversial problems in physics. Thousands of scientific, semi-scientific, and popular books and papers have been dedicated to it. However, this phenomenon, according to which the period of any clock increases proportionally to the square of its absolute velocity, is no more paradoxical than the conclusion to which Archimedes came, establishing that all bodies lose weight proportionally to their volumes when put in a liquid. It was only the theory of relativity which threw theoretical physics into confusion, since it tried to explain time dilation as a relative effect, cutting its natural logical tie with the absolute motion of the material systems.

11.2. DYNAMIC (EINSTEIN) TIME DILATION

Now we shall show that the period of any light clock increases when it is placed in a region with a stronger gravitational potential (we repeat — see §10.2 — that this gravitational potential, whose absolute value is greater, is stronger). We call this effect the **dynamic time dilation**, or the **Einstein time dilation**, since Einstein (1907) was the first to introduce it into physics.

As we are not interested in the kinematic aspect of the time dilation in this sub-section, we shall work in a frame which rests in absolute space. The clocks attached to absolute space have been called by us absolute (with more precision we shall call them **kinematically absolute**). The clocks moving in absolute space have been called proper (with more precision we shall call them **kinematically proper**). Clocks placed far enough from local concentrations of matter are to be called **dynamically absolute** and clocks placed near local concentrations of matter are to be called **dynamically proper**. These regions which in the problem considered have the weakest gravitational

potential (which *conditionally* is to be assumed equal to zero) can be considered as lying far enough from local concentrations of matter.

Consider two points with gravitational potentials Φ and Φ_n (if $|\Phi_n| > |\Phi|$, we can conditionally assume $\Phi = 0$). Suppose that a photon is emitted from the first point and received at the second. According to our tenth axiom, the velocities of the emitted and received photons, if measured on dynamically proper clocks, will be equal to c . If these velocities are measured on a unique clock (say, on a clock placed in the Φ -region), we shall designate them, respectively, by c and c^o and call them **dynamically absolute light velocity** and **dynamically proper light velocity**.

To find the relation between c^o and c suppose that the gravitational potential changes from the emission to the potential point in a stepped form. The potential « steps » can be infinitely near to each other, but, for clarity, we shall assume the distances between them to be larger than the photon wavelength. Now, according to our « burst » model for photons, we have to conclude that the rear of the « burst », when passing the i th potential « step », will change its velocity from c_i to c_{i+1} always with a time delay $\Delta t_i = \lambda_i/c_i$ after the head of the « burst », λ_i being the wavelength of the photon in the i th region. Thus the wavelength of the photon, after crossing the i th potential « step », will be

$$\lambda_{i+1} = c_{i+1} \Delta t_i = \frac{\lambda_i}{c_i} c_{i+1}. \quad (11.2)$$

If from the emission to the reception point there are n « steps », we have

$$\lambda_n = \lambda_n = \frac{\lambda_{n-1}}{c_{n-1}} c_n = \frac{\lambda_1}{c_1} c_n = \frac{\lambda}{c} c^o. \quad (11.3)$$

From (11.3) and (10.29) we obtain

$$c^o = c \frac{1 + \Phi_n/c^2}{1 + \Phi/c^2}. \quad (11.4)$$

This formula shows that the velocity of light in a stronger gravitational field is lower if measured on a *unique* clock.

The space regions in which velocity of light has the maximum possible value can be called **dynamically absolute space**. Obviously the space in which velocity of light is isotropic (i.e., has the same value along any direction) is to be called **kinematically absolute space**.

As the absolute times of emission and reception (i.e., the absolute periods) of the photon emitted in the Φ -region and received in the Φ_n -region are

$$T = \lambda/c, \quad T_n = \lambda_n/c^o, \quad (11.5)$$

we obtain, taking into account (10.29) and (11.4),

$$T_o = T. \quad (11.6)$$

The proper periods of the emitted and received photons are

$$T = \lambda/c, \quad T_o^\circ = \lambda_o/c. \quad (11.7)$$

From (11.7) and (10.29) we obtain

$$T_o^\circ = T \frac{1 + \Phi_o/c^2}{1 + \Phi/c^2}. \quad (11.8)$$

From (11.6) we conclude that if the frequencies of the emitted (ν) and received (ν_o) photons are measured in the same time (say, in absolute time), it must be

$$\nu_o = \nu. \quad (11.9)$$

From (11.4) we conclude that the relation between the periods T and T° of two light clocks with *equal* « arms » placed in the regions with gravitational potentials Φ and Φ_o , if measured on a unique, say, absolute, clock will be

$$T^\circ = T \frac{1 + \Phi/c^2}{1 + \Phi_o/c^2}. \quad (11.10)$$

Hence if for a certain period of time the absolute (the Φ -light-clock) has measured t time units and the proper (the Φ_o -light-clock) has measured t° time units, the relation between them will be

$$t^\circ = t \frac{1 + \Phi_o/c^2}{1 + \Phi/c^2}, \quad (11.11)$$

and this represents the phenomenon which we call the dynamic time dilation.

Regarding the generalization of dynamic time dilation in the case where the period is not determined by the motion of mass-less particles, we have to say the same as regarding the generalization of kinematic time dilation (see §11.1).

To explain in more detail the essence of dynamic time dilation, let us consider a light source which emits photons with frequency ν when being placed at a point with gravitational potential Φ . The period T of the emitted photon is equal to the time in which the emitting system passes through its two specific states, and we shall call T also the period of the emitting system. If we consider again an aerial emitting radio waves, then T is the time in which, say, the potential of the antenna's top passes through two successive maxima.

Transfer now the source of radiation to a region with a gravitational potential Φ_0 . Since the velocity of light in the Φ_0 -region, measured on the Φ -clock, is c^0 [see formula (11.4)], the period of the system, measured on the same Φ -clock, will become equal to T^0 and the relation between T and T^0 will be given by formula (11.10). Thus the relation between the frequencies ν and ν^0 (measured on a unique, say, absolute clock) of two *identical* material systems placed, respectively, in two regions with gravitational potentials Φ and Φ_0 will be

$$\nu^0 = \nu \frac{1 + \Phi_0/c^2}{1 + \Phi/c^2} \cong \nu [1 + (\Phi_0 - \Phi)/c^2]. \quad (11.12)$$

Hence if an observer is placed in a Φ -region and he receives photons which are emitted by two identical sources of radiation, the first placed in a Φ -region and the second in a Φ_0 -region, he will register a frequency ν for the photons arriving from the Φ -source and a frequency ν^0 for the photons arriving from the Φ_0 -source, the relation between them being given by formula (11.12). This is due to the fact that the frequencies of a photon emitted in the Φ -region and received in the Φ_0 -region are equal if measured on a unique clock [see (11.9)], but the frequencies of two *identical* Φ - and Φ_0 -sources are *not equal*, if measured on a unique clock, and the relation between them is given by formula (11.12).

This is the cause which leads to a shift in the spectroscopic lines observed on the Earth in the spectra of chemically identical stars' and Earth's gases.

Let us consider a mass m ($m \neq 0$) which, having velocity ν in the region with gravitational potential Φ , acquires the velocity ν_0 in the region with gravitational potential Φ_0 only as a result of the gravitational interaction between this mass and the masses producing the field. Proceeding from formula (10.24) and taking into account (5.8) and (10.23), we find

$$\frac{1 + \Phi_0/c^2}{(1 - \nu_0^2/c^2)^{1/2}} = \frac{1 + \Phi/c^2}{(1 - \nu^2/c^2)^{1/2}}. \quad (11.13)$$

This is the energy conservation law for a point mass in a gravitational field.

On the other hand, if two clocks move at velocities ν and ν_0 with respect to absolute space, then, according to kinematic time dilation, the relation between their readings t and t_0 , which correspond to the same absolute time interval, will be [see (3.19)]

$$t_0 = t \left(\frac{1 - \nu_0^2/c^2}{1 - \nu^2/c^2} \right)^{1/2}. \quad (11.14)$$

Comparing (11.11), (11.13) and (11.14), we come to the following very important conclusion : If we wish to change the rate of a clock, we have to change either its velocity or its gravitational potential. In both cases we have to expend the same quantity of work. Here we must mention that we have to expend the same quantity of work in absolute value, since from (11.13) we obtain, within an accuracy of second order in $1/c$,

$$\frac{1}{2} m v_0^2 - \frac{1}{2} m v^2 = - (m \Phi_0 - m \Phi), \quad (11.15)$$

and the gravitational energy (together with the gravitational potential) is negative, while the kinetic energy is positive. This can be established also with the following reasoning : If we wish to slow the rate of a clock « kinematically », we have to enhance its absolute velocity, and thus do *positive* work, while if we wish to achieve this « dynamically », we have to transfer the clock from a point with a weaker gravitational potential to a point with a stronger gravitational potential, and thus do *negative* work.

§12. COSMOLOGICAL ASPECTS OF LIGHT KINEMATICS

12.1. THE PHYSICAL ESSENCE OF REST ENERGY

We assume that the rest energy $e_r = mc^2$ of a material point is its gravitational energy with the mass of the whole Universe taken with a negative sign

$$m c^2 = m \gamma \int_V dm/r \quad \text{or} \quad c^2 = \gamma \int_V dm/r, \quad (12.1)$$

where r is the distance between a mass dm and our mass m , the integration being carried out over the volume V of the whole Universe. Thus we can call the rest energy of mass m its **universal gravitational energy**.

Since in §8.3 we mentioned that logic requests one to work with the reduced masses, we have to write (12.1) in the following form

$$m_c c = m_c \gamma \int_V dm_c/r \quad \text{or} \quad c = \gamma \int_V dm_c/r. \quad (12.2)$$

The second equation (12.2) gives the physical essence of light velocity. Its numerical value is determined by the matter of the whole Universe and its distribution, and represents the **universal gravitational potential** (divided by c !)

$$\Phi = - \gamma \int_V dm/r \quad \text{or} \quad \Phi_c = - \gamma \int_V dm_c/r \quad (12.3)$$

taken with a negative sign. The potential Φ_c is to be called the **reduced universal gravitational potential**.

If a reduced mass m_c changes its position from a Φ_c -region to a Φ_{c^0} -region, its reduced universal gravitational energy will change with

$$\Delta U_c = m_c \Phi_{c^0} - m_c \Phi_c, \quad (12.4)$$

and hence its reduced absolute (rest) time momentum (see §5)

$$\bar{p}_c = \bar{p}/c = m_c c \quad (12.5)$$

has to change with

$$\Delta \bar{p}_c = m_c c^0 - m_c c, \quad (12.6)$$

where c and c^0 are the velocities of light in the Φ_c - and Φ_{c^0} -regions.

Since the rest energy is the same thing as the universal gravitational energy, it must be

$$\Delta U_c = \Delta \bar{p}_c, \quad (12.7)$$

and from (12.4), (12.6) and (12.7) we obtain

$$c^0 = c \frac{1 + \Phi_{c^0}/c}{1 + \Phi_c/c^0}, \quad (12.8)$$

which, within the necessary accuracy, can be written in the form (11.4).

Let us note that when a mass changes its position, and correspondingly its gravitational energy changes, then, according to the energy conservation law (11.15), its kinetic energy changes by the same amount, taken with a negative sign. However, when a mass changes its position, its universal gravitational energy also changes, and since the rest energy is *another form* of writing the universal gravitational energy, the velocity of light must correspondingly change its value. Formula (10.24) represents the energy conservation law, while formula (12.7) represents an equality between two *identical quantities*.

We shall now briefly discuss the problem about the experimental confirmation of our hypothesis (12.1).

First we have to answer the question about the model of the Universe which our absolute space-time theory puts forward. By the help of observations, it has been established that the Universe represents a system of galaxies and clusters of galaxies which are distributed homogeneously in space. Thus, as a reasonable approximation, we can consider the Universe as a sphere with radius R tending to infinity and with an average constant mass density μ_n .

We shall suppose that outside this sphere there is a void. The universal gravitational potential for such a model of the Universe will be

$$\Phi = -\gamma \int_0^R \frac{\mu_{av}}{r} dV = -4\pi\gamma\mu_{av} \int_0^R r dr = -2\pi\gamma\mu_{av} R^2. \quad (12.9)$$

From (12.1), (12.3) and (12.9) we obtain the following expression for light velocity

$$c^2 = 2\pi\gamma\mu_{av} R^2. \quad (12.10)$$

Thus if our hypothesis is adequate to physical reality, the average mass density and corresponding « radius » of the Universe, which are experimentally established, must satisfy the relation

$$\mu_{av} R^2 \leq c^2/2\pi\gamma = 2.10^{27} \text{ g cm}^{-1}, \quad (12.11)$$

since always some mass will remain outside the sphere with radius R which has been taken as a « radius of the observable Universe ».

At the present time the experimental data are (Menzel *et al.*, 1970)

$$\mu_{av} = 10^{-30} \text{ g cm}^{-3}, \quad R = 3.10^{28} \text{ cm}, \quad \text{thus } \mu_{av} R^2 = 9.10^{26} \text{ g cm}^{-1}. \quad (12.12)$$

12.2. THE PHYSICAL ESSENCE OF COSMOLOGICAL « RED SHIFT »

Hubble (1937), on the grounds of statistics of observational data, established that the wavelengths of light coming from distant galaxies are shifted according to the law (called **Hubble's law**)

$$\frac{\lambda_0 - \lambda}{\lambda} \equiv \frac{\Delta\lambda}{\lambda} = H r, \quad (12.13)$$

where λ is the wavelength of the photons which the luminescent gas observed in the galaxy emits on the Earth, λ_0 is the wavelength actually observed, r is the distance to the galaxy and H is the so-called **Hubble constant**.

Since it is $\lambda_0 > \lambda$, then the visible spectral lines are always shifted to the red end and this effect is called also the **cosmological « red shift »**.

Conventional physics and astronomy *hypothetically* assume that the galaxies are receding from each other, the recession velocity being proportional to the distance between them, so that the cosmological « red shift » is

due to the appearing Doppler effect*. Since we have established by means of our « coupled-mirrors » experiment (§19.2) that the Sun moves at a velocity of about 300 km/s with respect to absolute space, then one has to accept that our Sun is situated very near to the « centre » of the Universe, because the cosmological « red shift » for remote galaxies, if considered as a Doppler effect, corresponds to recession velocities approaching c . So, for instance, the quasar PKS 0237-23 has a « red shift » $\Delta\lambda/\lambda = 2,22$, and if we should accept that this shift is due to a longitudinal Doppler effect, then on the grounds of the second formula (10.8), where we put $\theta_m = 0$, we shall obtain $v = 247.000$ km/s.

Thus we consider the recession hypothesis as highly artificial, since the probability that among millions of galaxies it is ours which is exactly at the « centre » of the Universe is very low.

In our absolute space-time theory we explain the cosmological « red shift » by the gravitational action of the masses of the whole Universe, calling it the **cosmological gravitational frequency and wavelength shift**, while the « red shift » in the spectral lines of light emitted from a star and due to the gravitational action of the mass only of this star is called the **stellar gravitational frequency and wavelength shift**.

Let us consider mathematically the cosmological gravitational shift.

If there is a sphere with radius R whose mass density $\mu = \mu(r)$ has a central symmetry, then the gravitational potential at a point distance r from the centre can be calculated from the following formula

$$\Phi(r) = -4\pi\gamma \int_r^R \mu r' dr' - \frac{4\pi}{r} \gamma \int_0^r \mu r'^2 dr'. \quad (12.14)$$

* Burcev [*Phys. Lett.*, 27A, 623 (1968)] put forward the hypothesis of rotating quasars (and galaxies) explaining the large red shifts as a transverse Doppler effect. This conclusion is due to an incorrect treatment of the light Doppler effect formulas. Taking into account §10.1 (see also §30), one should immediately establish that Burcev analyses only the formula for the post-traverse Doppler effect (i.e., he assumes that there is no radial component when the angle between the source-observer line and the direction of the relative velocity is equal to $\pi/2$ at the moment of emission). If one should analyse the formula for the ante-traverse Doppler effect (i.e., if one assumes that there is no radial component when the angle between the source-observer line and the relative velocity is equal to $\pi/2$ at the moment of reception), then one should come to the conclusion that at a suitable value of the transverse component a blue shift would be seen for any value of the radial component.

Supposing $\mu = \mu_{av} = \text{Const}$, we obtain for the difference between the gravitational potentials at the centre of the sphere and at a point distance $r (< R)$ the following expression

$$\Delta\Phi(r) \equiv \Phi(0) - \Phi(r) = -\frac{2}{3} \pi \gamma \mu_{av} r^2. \quad (12.15)$$

We assert that always the point of emission is to be put at the centre of the Universe because the point of emission is only *one*, while the points of reception can be an *infinite quantity*, and we assume that there is *no* such centre as the Universe is without limits and thus *any* point can be considered as its centre. Here our conceptions are almost identical with those of Nicolaus Cusanus (1401-1464), one of the most brilliant minds in history, who forwarded the following cosmological model: « The Universe is a sphere whose centre is everywhere and the surface nowhere ».

If a photon emitted from a space region with gravitational potential $\Phi = \Delta\Phi(0)$ has a wavelength λ , then in a space region with gravitational potential $\Phi_0 = \Delta\Phi(r)$ this photon will have a wavelength λ_0 and the relation between all these quantities will be given by formula (10.29). Thus, substituting into this formula the potential (12.15) for $r = 0$ and $r = r$, we obtain

$$\lambda_0 = \frac{\lambda}{1 - \frac{2}{3} \frac{\pi \gamma}{c^2} \mu_{av} r^2}, \quad (12.16)$$

which formula for $r \ll R$ [see (12.10)] can be written

$$\frac{\lambda_0 - \lambda}{\lambda} = \frac{2}{3} \frac{\pi \gamma}{c^2} \mu_{av} r^2. \quad (12.17)$$

Denoting

$$H_M^2 = \frac{2}{3} \frac{\pi \gamma}{c^2} \mu_{av}, \quad (12.18)$$

and calling H_M the **Hubble-Marinov constant**, we can write (12.17) in the form

$$\frac{\lambda_0 - \lambda}{\lambda} \equiv \frac{\Delta\lambda}{\lambda} = H_M^2 r^2, \quad (12.19)$$

which we call the **Hubble-Marinov law**.

Plotting the red shifts $\Delta\lambda/\lambda$ of the remote galaxies (observed spectroscopically) versus their distances to the Earth (estimated from their visual magnitudes at the assumption that the absolute magnitudes are equal), one can find the value of the Hubble-Marinov constant, and then from equation (12.18) one can calculate the average mass density in the Universe.

We have done this in Marinov (1978g), establishing $H_M = 1.98 \cdot 10^{-29} \text{ cm}^{-1}$. Taking for μ_{av} the statistically established value (12.12), we find, according to formula (12.18), $H_M = 1,25 \cdot 10^{-29} \text{ cm}^{-1}$.

We show in Marinov (1978g) that our theoretical *quadratic* relation (12.19) fits much better to the experimental points of the dependence « red shift — distance » than the hypothetical *linear* Hubble relation (12.13).

Formula (12.16) shows that for $r \rightarrow R$, where R is the « radius » of the Universe, it is [see formula (12.10)]

$$\frac{2\pi}{3} \frac{\gamma}{c^2} \mu_{av} R^2 \cong 2\pi \frac{\gamma}{c^2} \mu_{av} R^2 = 1, \quad (12.20)$$

so that $\lambda_n \rightarrow \infty$. For this reason, even if there is a matter outside the sphere with radius R , we can receive no information about it because the photons which would come from there will be extremely faint, i.e., with an extreme low energy.

Hence, according to our conceptions, even under the assumption of an infinite Universe, factually the Universe must be regarded as finite as we cannot « look » outside the sphere with radius R established from relation (12.10). Of course, if a space traveller undertakes a cosmic journey, then new galaxies will enter into the sphere of his Universe along the line of his motion and the most « red » galaxies in the opposite direction will disappear; sailors experience similar phenomena when they pass islands and other ships. Thus we can call R not « radius of the world » but « radius of the world's horizon ».

Ending this section, we must emphasize that, since cosmology operates with conditions at infinity, one can never be sure whether one's world model is adequate to reality.

§13. PROPAGATION OF LIGHT IN A MEDIUM

13.1. DRAG

In classical (i.e., non-quantum) physics we consider only the gravitational and electromagnetic interactions of particles (with masses different from or equal to zero). In the axiomatics of classical physics we do not introduce any assertion about the phenomenon « collision » (respectively, « coalescence » and « disintegration ») of particles. All these problems are to be considered in quantum physics. However, under certain *idealized* assumptions we can consider some aspects of these phenomena also in classical physics. These assumptions are :

a) The sizes of the material points are small enough with respect to the distances between them, so that we can ignore their sizes altogether.

b) When the particles collide (respectively, coalesce or disintegrate) we take into account only the laws of conservation (see the end of §6.2), applying them to the particles before and after the collision (respectively, coalescence or disintegration).

The emission of a photon (i.e., of a particle with mass equal to zero) by a particle with mass different from zero represents a disintegration of a particle. The absorption (reception) of a photon by a particle represents a coalescence of particles.

When a photon propagates through a **medium** (i.e., through a space region in which many particles are dispersed) it will collide with the first « hit » particle, and be absorbed, reflected (dispersed) or re-emitted. In the first case we call the medium « opaque » and in the last « transparent ». As a rule, the re-emission of a photon by a particle occurs a certain time after its absorption. This is our « model » for the propagation of light in a medium. As a matter of fact, in this « model » we do not introduce additional characteristics for the quantity « particle » other than those introduced in our third axiom, and thus there is no new assertion which merits being introduced in the axiomatics.

The problem about the velocity of light in a transparent medium when the medium or the observer or both move with respect to absolute space is considered in Marinov (1974a, 1976b). A review of the theoretical parts of these papers follows.

A. Medium and observer at rest.

Let us have a medium which rests in absolute space. If, in a unit of time, a photon crosses a distance c/n through the medium and if, for the sake of simplicity, we assume that it is always being re-emitted by the particles in the same direction along which it hits them, then we must conclude that the photon propagates $(1/n)$ th part of the time unit as a « free » photon and $(1 - 1/n)$ th part of the time unit it rests « absorbed » (or « hitched ») by the particles. Thus with respect to an observer who is also at rest in absolute space, it moves with the mean velocity

$$c_m = c/n. \quad (13.1)$$

The factor n is called the **refractive index** of the medium.

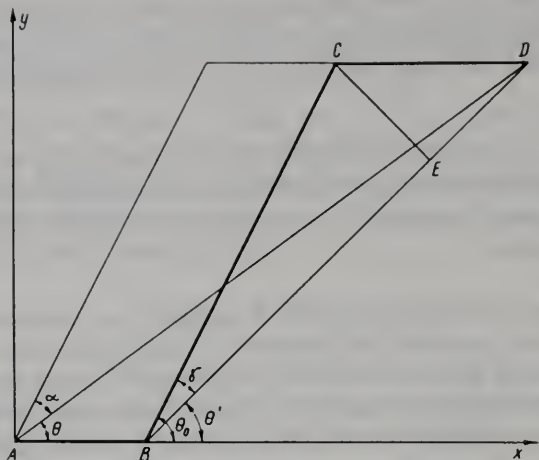

Fig. 13-1

B. Medium moving, observer at rest.

Let us now calculate the velocity of light in a medium moving with velocity v in absolute space with respect to an observer who is at rest.

Suppose first (fig. 13-1) that the medium moves with velocity v along the x -axis of the used rest frame K only during this time when the photon is absorbed by some particle (molecule) of the medium and suppose that during the time between the re-emission and next absorption the medium (the molecule) is at rest. If we consider the path of the photon between two successive absorptions, then this path can be presented by the broken line ABC in fig. 13-1. Supposing that the time between two successive absorptions is chosen for a time unit, i.e., that

$$AB/v + BC/c = 1, \quad (13.2)$$

we obtain

$$AB = v(1 - 1/n), \quad BC = c/n. \quad (13.3)$$

If now we suppose that the medium moves with velocity v during the whole time, then the next molecule will be caught not at point C but at point D , where the distance CD is covered by this molecule in the time in which the photon covers distance BD , i.e.,

$$CD = v/n. \quad (13.4)$$

Thus now the distance covered by the photon between two successive re-emission and absorption will not be BC but

$$BD = BE + ED = \left(\frac{c^2}{n^2} - \frac{v^2}{n^2} \sin^2 \theta' \right)^{1/2} + \frac{v}{n} \cos \theta', \quad (13.5)$$

where

$$\theta' = \theta_0 - \gamma \quad (13.6)$$

is the angle between the « free path » of the photon and the velocity of the medium with respect to the observer (i.e., to frame K) while θ_0 is the same angle with respect to the medium (i.e., to the moving frame K' which is attached to the medium). The angle

$$\gamma = \arcsin \frac{CE}{BC} \cong \frac{v/n}{c/n} \sin \theta' \cong \frac{v}{c} \sin \theta_0 \quad (13.7)$$

represents the difference between these two angles which is small and, as we shall further see, it is enough to consider it with an accuracy of first order in v/c .

Within the same accuracy of first order in v/c we can write, having in mind (13.6) and (13.7),

$$\cos \theta' = \cos \theta_0 + \frac{v}{c} \sin^2 \theta_0. \quad (13.8)$$

The distance covered by the photon between two successive absorptions with respect to the observer will be

$$AD^2 = (AB + CD)^2 + BC^2 + 2(AB + CD)BC \cos \theta_0. \quad (13.9)$$

Putting here (13.3) and (13.4), and working with an accuracy of second order in v/c , we obtain

$$AD = \left(\frac{c^2}{n^2} + 2 \frac{vc}{n} \cos \theta_0 + v^2 \right)^{1/2} = \frac{c}{n} + v \cos \theta_0 + \frac{1}{2} \frac{v^2}{c} n \sin^2 \theta_0. \quad (13.10)$$

To obtain the mean velocity of the photon with respect to the observer, we have to divide the distance AD by the time for which the broken line ABD is covered. This time, taken with an accuracy of second order in v/c , is

$$\begin{aligned} t_m &= \frac{AB}{v} + \frac{BD}{c} = 1 + \frac{v}{cn} \cos \theta' - \frac{1}{2} \frac{v^2}{c^2 n} \sin^2 \theta' = \\ &= 1 + \frac{v}{cn} \cos \theta_0 + \frac{1}{2} \frac{v^2}{c^2 n} \sin^2 \theta_0, \end{aligned} \quad (13.11)$$

where we have used (13.3), (13.5) and (13.8).

Thus, for the mean velocity of the photon in the moving medium measured by the observer at rest, we get, within an accuracy of second order in v/c ,

$$c_m = \frac{AD}{t_m} = \frac{c}{n} + v \left(1 - \frac{1}{n^2}\right) \cos \theta_o - \frac{v^2}{cn} \left(1 - \frac{1}{n^2}\right) \cos^2 \theta_o + \frac{1}{2} \frac{v^2 n}{c} \left(1 - \frac{1}{n^2}\right) \sin^2 \theta_o, \quad (13.12)$$

having suppressed the factor n in the denominator of the last term on the right side of (13.11).

Let us introduce the angle between the velocity of the medium and the mean velocity of the photon which is measured by the observer at rest

$$\theta = \theta_o - \alpha, \quad (13.13)$$

where

$$\alpha \cong \frac{v \sin \theta}{c/n} = \frac{v n}{c} \sin \theta \quad (13.14)$$

is the difference between the angles θ_o and θ which is small and can be considered only with an accuracy of first order in v/c .

Within the same accuracy of first order in v/c we can write, having in mind (13.13) and (13.14),

$$\cos \theta_o = \cos \theta - \frac{v n}{c} \sin^2 \theta. \quad (13.15)$$

Substituting this into (13.12), we find

$$c_m = \frac{c}{n} + v \left(1 - \frac{1}{n^2}\right) \cos \theta - \frac{v^2}{cn} \left(1 - \frac{1}{n^2}\right) \cos^2 \theta - \frac{1}{2} \frac{v^2}{c} n \left(1 - \frac{1}{n^2}\right) \sin^2 \theta. \quad (13.16)$$

The « model » for the propagation of photons in a moving medium described here is called by us the « hitch-hiker » model. Let us mention that in our youth, when crossing countries by « hitch-hiking », we never waited for the next car at the same point where being dropped by the previous one, but always tried to « gain » more distance by walking. Of course, our pedestrian velocity could never be higher than that of the cars.

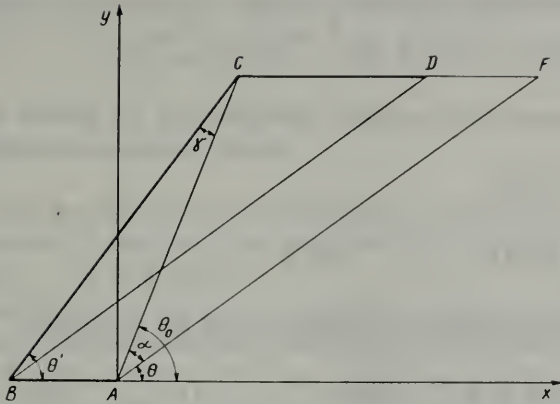

Fig. 13-2

C. Medium at rest, observer moving.

Let there be (fig. 13-2) a medium with refractive index n that is at rest in absolute space and in which light propagates along a direction that makes an angle θ with the x -axis of a frame K attached to absolute space. Let an observer attached to a frame K' move at velocity v along the positive direction of the x -axis of frame K , and suppose that the x -axes of both frames are colinear.

We choose again the time between two successive absorptions of a photon on the molecules of the medium as a time unit. At such a choice of the time unit a photon propagating along the direction AF in the rest frame K is « hitched » $(1 - 1/n)$ th part of the time unit on a molecule which rests at point A , and $(1/n)$ th part of the time unit moves along the line AF until it will be « hitched » again on another molecule which rests at point F .

In the moving frame K' we have the following picture : During the time in which the photon is « hitched » it will cover distance AB with velocity v and during the time in which the photon propagates with velocity c in absolute space it will cover distance BC in K' (under an angle θ' to the x' -axis) with the proper relative velocity [see (3.32)]

$$c'_0 = \frac{c}{1 + v \cos \theta' / c}, \quad (13.17)$$

since during the time in which the photon has covered the broken line ABC in frame K' the molecule that rests at point F in absolute space has covered distance FC in K' with velocity v . The mean proper relative light velocity in

frame K' (i.e., the average light velocity measured in K' by the help of a clock which rests there) will make an angle θ_0 with the x' -axis and have magnitude

$$c'_{om} = AC = (AB^2 + BC^2 - 2ABBC \cos \theta')^{1/2}, \quad (13.18)$$

since the time between two successive absorptions of the photon is taken equal to unity.

Putting into (13.18)

$$AB = v(1 - \frac{1}{n}), \quad BC = \frac{c}{1 + v \cos \theta' / c} \frac{1}{n} \quad (13.19)$$

and working within an accuracy of second order in v/c , we obtain

$$c'_{om} = \frac{c}{n} - v \cos \theta' + \frac{v^2}{cn} \cos^2 \theta' + \frac{1}{2} \frac{v^2}{c} n (1 - \frac{1}{n})^2 \sin^2 \theta'. \quad (13.20)$$

The angle which the observer in frame K' will measure between the direction of propagation of light and his own velocity is θ_0 . Thus, putting into (13.20)

$$\theta' = \theta_0 - \gamma, \quad (13.21)$$

where γ is a small angle and, as we shall further see, within the necessary accuracy we can take

$$\sin \gamma = \frac{AB \sin \theta'}{AC} \cong \frac{v}{c} (n - 1) \sin \theta' \cong \frac{v}{c} (n - 1) \sin \theta_0, \quad (13.22)$$

we obtain

$$c'_{om} = \frac{c}{n} - v \cos \theta_0 + \frac{v^2}{cn} \cos^2 \theta_0 - \frac{1}{2} \frac{v^2}{c} n (1 - \frac{1}{n^2}) \sin^2 \theta_0. \quad (13.23)$$

The angle between the direction of propagation of light and the velocity of the observer which should be measured in frame K is θ . Thus, putting into (13.23)

$$\theta_0 = \theta + \alpha, \quad (13.24)$$

where α is a small angle and, as we shall further see, within the necessary accuracy we can take

$$\sin \alpha = \frac{CF \sin \theta}{AC} \cong \frac{v}{c} n \sin \theta, \quad (13.25)$$

we obtain

$$c'_{om} = \frac{c}{n} - v \cos \theta + \frac{v^2}{cn} \cos^2 \theta + \frac{1}{2} \frac{v^2}{c} n \left(1 + \frac{1}{n^2}\right) \sin^2 \theta. \quad (13.26)$$

D. Medium and observer moving.

Let us now find the velocity of light in a medium moving at velocity v with respect to absolute space measured by an observer attached to the medium.

Since in such a case for $(1 - 1/n)$ th part of the time unit the photon is « hitched » and does not move with respect to the moving frame K' which is attached to the medium, then the « effective » velocity of the frame with respect to the trajectory of the « free » photon will be v/n . Thus, according to formula (3.32), the proper velocity of the « free » photon with respect to K' will be [write in (3.32) $V = v/n$]

$$c'_o = \frac{c}{1 + \frac{v}{cn} \cos \theta'} = c \frac{1 - \frac{v}{cn} \cos \theta}{1 - \frac{v^2}{c^2 n^2}}. \quad (13.27)$$

The photon moves with this velocity only $(1/n)$ th part of the time unit, so that the mean proper velocity of light with respect to K' will be

$$c'_{om} = \frac{1}{n} c'_o = \frac{c}{n} \frac{1}{1 + \frac{v}{cn} \cos \theta'} = \frac{c}{n} \frac{1 - \frac{v}{cn} \cos \theta}{1 - \frac{v^2}{c^2 n^2}}, \quad (13.28)$$

where θ' and θ are the angles between the direction of light propagation and the velocity of the medium measured, respectively, in the moving and rest frames.

13.2. REFRACTION

In this sub-section we shall show that our model for the propagation of light in a medium as a process of successive « absorptions » and « re-emissions » of the photons leads immediately to Snell's law for the refraction of light.

We shall perform the calculation by considering a bundle of photons (a light beam) which is incident under an angle φ on the boundary between the

media A and B with refractive indices n_A and n_B . Consider two photons which lie on the extremities of the bundle and on a line which is perpendicular to the bundle. Suppose that the distance between the points at which both flank-photons cross the boundary is d . After the instance at which the first flank-photon crosses the boundary, the second flank-photon has to move a certain time t with the velocity c/n_A in the medium A and cover a distance $d \sin \varphi$, until it also reaches the boundary. Thus we can write

$$t = \frac{d \sin \varphi}{c/n_A}. \quad (13.29)$$

During this time t , the first photon will move with velocity c/n_B in the medium B and will cover the distance $d \sin \psi$, where ψ is the refractive angle (note that when the second flank-photon has reached the boundary the first and second flank-photons must lie on a line which is perpendicular to the bundle). Thus we can write

$$t = \frac{d \sin \psi}{c/n_B}. \quad (13.30)$$

From the last two formulas we obtain Snell's law

$$\frac{\sin \psi}{\sin \varphi} = \frac{n_A}{n_B}. \quad (13.31)$$

13.3. COLLISION BETWEEN PHOTONS AND PARTICLES

As we said, when particles collide, we shall describe the phenomenon, taking into account only the laws of conservation and applying them to the systems of particles before and after the collision.

In this sub-section we shall consider only the **elastic collision** (i.e., a collision in which the masses of the particles before and after the collision remain the same) between a photon and a particle with mass different from zero (the so-called **Compton effect**). We shall show that the Compton effect represents nothing but a light Doppler-effect where the energy of the « mirror-receiver » is comparable with the energy of the striking photon so that, under the hit of the photon, the « mirror-receiver » changes its velocity.

As we have mentioned in Marinov (1978h), several authors have pointed out the equivalence between the Compton and Doppler effects. However, all these authors have treated this problem by considering the Compton scattering on particles at rest. We shall consider the more general case of collision between a photon and a moving particle where the Doppler essence of the Compton scattering becomes more obvious.

The momentum and energy conservation laws applied to the elastic collision of a photon and a particle with mass m are [see (4.4), (5.8) and (9.10)]

$$\frac{m \mathbf{v}}{(1 - v^2/c^2)^{1/2}} + \frac{h\nu}{c} \mathbf{n} = \frac{m \mathbf{v}'}{(1 - v'^2/c^2)^{1/2}} + \frac{h\nu'}{c} \mathbf{n}'$$

$$\frac{m c^2}{(1 - v^2/c^2)^{1/2}} + h\nu = \frac{m c^2}{(1 - v'^2/c^2)^{1/2}} + h\nu'$$
(13.32)

where \mathbf{v}, \mathbf{v}' are the velocities of the particle before and after the collision; ν, ν' are the frequencies and \mathbf{n}, \mathbf{n}' are the directions of propagation of the photon before and after the collision.

Squaring both these equations and subtracting the first from the second, we obtain

$$\nu' = \nu \frac{1 - \frac{v}{c} \cos(\mathbf{v}, \mathbf{n})}{1 - \frac{v'}{c} \cos(\mathbf{v}', \mathbf{n}')} \left(\frac{1 - v'^2/c^2}{1 - v^2/c^2} \right)^{1/2}$$
(13.33)

This is the dependence between the characteristics of the photon and of the particle before and after the collision in which only 3-dimensional invariants are involved. If we interchange the places of the different terms in equations (13.32) before squaring them, other formulas can be obtained for the description of the Compton effect where the cosines of other angles will appear.

The collision can be considered as « absorption » of the photon by the particle followed by an immediate « re-emission ». The « absorbed » frequency of the photon will be denoted by ν_{int} (ν intermediary) and the « re-emitted » frequency (which can be received by an observer at rest) by ν' .

According to the second formula (10.12), where we write $\nu_0 = \nu_{\text{int}}$, we shall have

$$\nu_{\text{int}} = \nu \frac{1 - \frac{v}{c} \cos(\mathbf{v}, \mathbf{n})}{(1 - v^2/c^2)^{1/2}}$$
(13.34)

since $\theta = (\mathbf{v}, \mathbf{n})$ is the angle between the velocity of the observer (the hit particle) and the direction of the wave vector of the emitted light at the moment of reception (« absorption »).

According to the first formula (10.5), where we write $\nu_0 = \nu', \nu = \nu_{\text{int}}, \mathbf{v} = \mathbf{v}'$, we shall have

$$\nu' = \nu_{\text{int}} \frac{(1 - v'^2/c^2)^{1/2}}{1 + \frac{v}{c} \cos(\mathbf{v}', -\mathbf{n}')} ,$$
(13.35)

since $\theta' = (\mathbf{v}', -\mathbf{n}')$ is the angle between the velocity of the source and the opposite direction of the wave vector of the reflected light at the moment of emission (« re-emission »).

From the last two formulas we obtain the result (13.33).

We must emphasize that when the particle is elementary (for example, an electron) its mass cannot change and the « re-emission » must follow immediately after the « absorption », i.e., the photon will only be « reflected » by the particle. If the particle is compound (for example, an atom), its mass can change and the « re-emission » can follow a certain time after the absorption.

The Doppler effect formulas give the relation between the frequencies of the emitted and observed light when source and observer move with respect to one another. In the Compton effect source and observer are at rest. However, between them there is a moving « mirror » (the particle) which, moreover, changes its velocity under the hit of the photon. Hence it is obvious that the relation to which the Doppler effect formulas lead (where we are interested only in the mirror's velocity before and after the reflection of the photon) must be the same as the relation which can be obtained from the momentum and energy conservation laws.

Formulas (13.32) represent four relations for six unknown quantities : \mathbf{v}' , ν' , \mathbf{n}' . Thus two of these quantities must be taken arbitrarily and they are determined by the unit vector \mathbf{n}_r which is perpendicular to the « reflecting plane » of the moving mirror (Doppler treatment) or by the unit vector \mathbf{n}' along the direction of propagation of the « re-emitted » photon (Compton treatment). Using the law of light reflection (the incident and reflected rays lie in the same plane with the perpendicular to the reflecting plane and make equal angles with it), we can find \mathbf{n}_r when \mathbf{n} and \mathbf{n}' are given, or \mathbf{n}' when \mathbf{n} and \mathbf{n}_r are given.

Thus the Compton scattering represents a Doppler effect where one observes reflection of light from a « mirror » which changes its velocity under the action of any *single* incident photon.

13.4. RELATION BETWEEN REFRACTIVE INDEX AND DENSITY

The relation between the refractive index n of a transparent medium and its density μ is given by the well-known formula of Lorentz-Lorenz [see, for example, Lorentz (1916)]

$$\frac{n^2 - 1}{n^2 + 2} \frac{1}{\mu} = K_L, \quad (13.36)$$

where K_L is a constant which we call the **Lorentz-Lorenz constant**.

Our « model » for the propagation of light in a transparent medium leads to the following relation

$$\frac{n - 1}{\mu} = K_M, \quad (13.37)$$

where K_M is a constant which we call the **Marinov constant**.

We come to formula (13.37) in the following extremely simple way : As we stated (§13.1), at a density μ of the transparent medium, $1/n$ is the time in which, on average, the photon travels with velocity c in vacuum and $1 - 1/n$ is the time during which, on average, the photon remains « hitched » to the molecules of the medium. Now suppose that the density of the medium has changed from μ to μ' . The refractive index will change, respectively, from n to n' . For that distance for which the photon was « hitched » $1 - 1/n$ seconds and has traveled $1/n$ seconds it will now be « hitched »

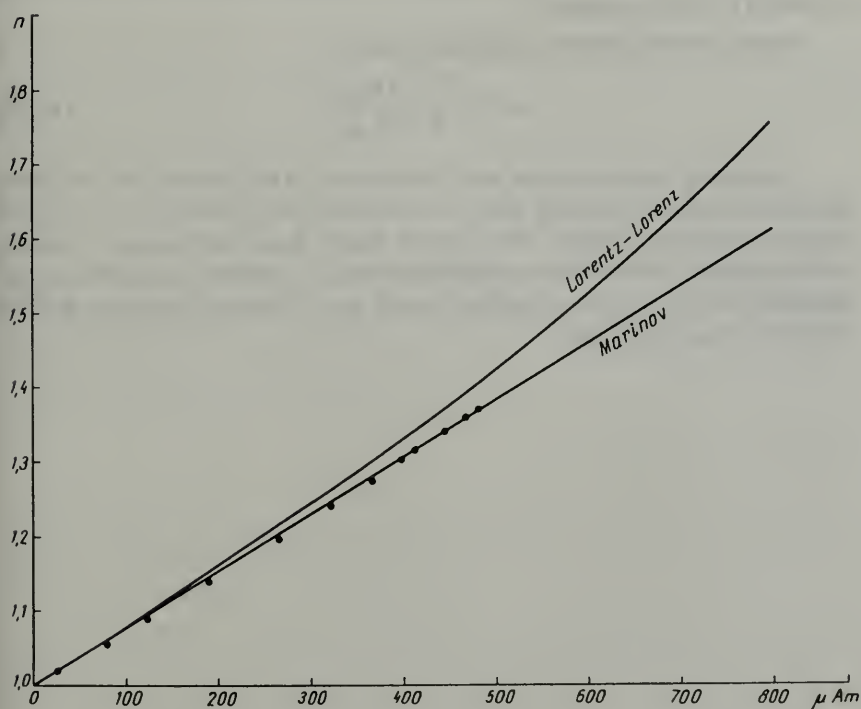

Fig. 13-3

$(\mu'/\mu)(1 - 1/n)$ seconds and, as before, will travel $1/n$ seconds, since the sum of the « free flight » distances remains the same and only the number of the « hitch-points » has changed. Thus we can write

$$1 - \frac{1}{n'} = \frac{\frac{\mu'}{\mu} (1 - \frac{1}{n})}{\frac{\mu'}{\mu} (1 - \frac{1}{n}) + \frac{1}{n}} \quad (13.38)$$

From here formula (13.37) can immediately be obtained.

In Marinov (1978i) we show that our formula (13.37) finds a better support in the experiment than the Lorentz-Lorentz formula (13.36). In fig. 13-3 we give the graphs of n as a function of μ according to formulas (13.36) and (13.37). The experimental points are taken from Michels *et al.* (1947), who have measured this dependence for ethylene (μ is given in Amagat units).

However, even without looking at the experiment, we can show that formula (13.36) is *unsound*.

Indeed, write formula (13.36) in the form

$$n = \left(\frac{1 + 2 K_L \mu}{1 - K_L \mu} \right)^{1/2} \quad (13.39)$$

According to this formula, with the increase of the density, the refractive index increases very rapidly and for a certain critical density $\mu_{cr} = 1/K_L$ it becomes equal to infinity. The Lorentz theory [see, for example, Lorentz (1916)] cannot offer a sound explanation to this peculiarity. According to our formula (13.37), no such peculiarity exists, and n becomes equal to infinity only for μ equal to infinity.

PART II — EXPERIMENTAL

§ 14. INTRODUCTION

In this second part we shall give short accounts of the most important experiments which we consider decisive for the refutation of the principle of relativity, for the rejection of the relativistic space-time conceptions and for the restoration of the old Newtonian absolute conceptions dressed in the clothes of our absolute space-time theory.

Certain of the experiments can reveal the absolute motion of the laboratory, others cannot reveal it practically because all absolute effects cancel each other in the effect to be measured. On the other hand, certain experiments can give reliable effects when today's experimental technique is used, others cannot.

We describe all these experiments, concentrating our attention on their essence, without entering into the details which the reader can find in the original papers. Additional references to other authors can be found in the same papers.

We consider the « coupled-mirrors » experiment (§19) and the « rotating disk » experiments (§25 and § 26) as decisive for the rejection of Einstein's conceptions. The analysis of the other experiments (ours and of other authors) can strengthen one's faith in space-time absoluteness.

§ 15. THE QUASI-RØEMER EXPERIMENT

With the help of the Rømer experiment (i.e., the observation of the eclipses of a Jupiter satellite from the Earth during the course of a year) for the first time in history the velocity of light was measured. If this experiment be performed with the aim of measuring the Earth's absolute velocity, we call it the **quasi-Rømer experiment**.

Now we shall show that according to our absolute space-time theory the Earth's absolute motion cannot be revealed by the help of the quasi-Rømer experiment. This problem is considered in detail in Marinov (1978j).

Suppose (fig. 15-1) that at the initial year of observation when the Earth and Jupiter are in opposition the absolute velocity of the Sun system v_s makes an angle θ with the opposition line.

Let us observe the zeroth eclipse of the satellite at the moment t'' , read on a terrestrial clock, when the Earth and Jupiter are at the positions E_0, J_0 , i.e., half a year before the moment when they will be in opposition.

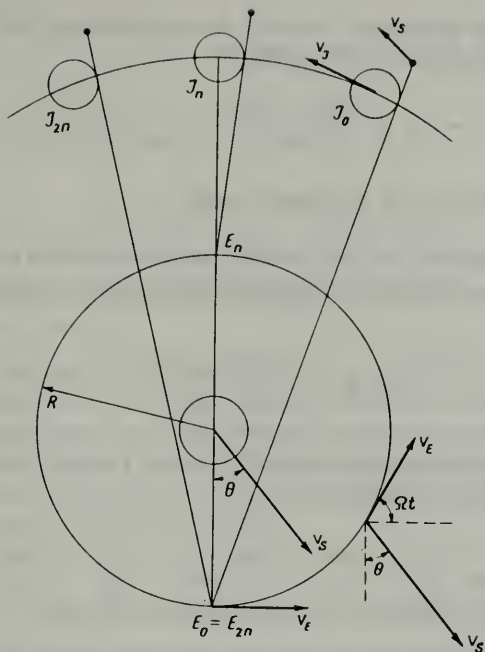

Fig. 15-1

The first eclipse will occur at the moment

$$t' = t^0 + T - \frac{J_1 E_1 - J_0 E_0}{c'_0}, \quad (15.1)$$

where T is the period of revolution of the satellite, E_1, J_1 are the positions of the Earth and Jupiter at the moment t' , and c'_0 is the proper relative velocity of light coming from Jupiter with respect to the Sun system.

According to formula (3.32), where we write $V = v_s$, we have

$$c'_0 = \frac{c}{1 + v_s \cos \theta' / c} = c \frac{1 - v_s \cos \theta / c}{1 - v_s^2 / c^2}, \quad (15.2)$$

where θ' is the angle between v_s and the line of light propagation registered with respect to the moving Sun's frame and θ is the same angle registered with respect to absolute space.

Since Jupiter covers (1/12)th part of its orbit during an Earth year, we shall assume that the positions J_0, J_1 are very near to one another. Thus in (15.2) we can consider angle θ' ($\cong \theta$ within the necessary accuracy) to be equal to angle θ in fig. 15-1, i.e., to the angle between the opposition line and the Sun's absolute velocity.

Let the n th eclipse be observed at the moment t^n when the Earth and Jupiter are in opposition. We shall have

$$\Delta t_0^n = t^n - t^0 = nT - \frac{J_n E_n - J_0 E_0}{c_0'} = nT - \frac{2R}{c} \left(1 + \frac{v_s}{c} \cos \theta\right), \quad (15.3)$$

where R is the radius of the Earth's orbit.

Finally, suppose that the $2n$ th eclipse is observed at the moment t^{2n} after another half-year when the Earth and Jupiter are at the positions E_{2n}, J_{2n} .

We have

$$\Delta t_0^{2n} = t^{2n} - t^0 = 2nT - \frac{J_{2n} E_{2n} - J_0 E_0}{c_0'} = 2nT. \quad (15.4)$$

From here we can determine the period T of revolution of the satellite. Using (15.4) in (15.3), we find

$$\Delta t_0^n = \frac{\Delta t_0^{2n}}{2} - \frac{2R}{c} - \frac{2Rv_s}{c^2} \cos \theta = \overline{\Delta t_0^n} - \frac{2Rv_s}{c^2} \cos \theta, \quad (15.5)$$

where $\overline{\Delta t_0^n}$ is this time interval which follows the initial moment, after whose elapsing one has to observe the n th eclipse if the absolute velocity of the Sun is equal to zero, or if the velocity of light is not direction dependent. When Rømer made his observations, he compared the calculated time interval $\Delta t_0^{2n}/2$ with the really measured time interval Δt_0^n and, knowing R , he established c .

Any traditional absolutist would conclude that making use of formula (15.5) one could establish the component v_s of the Sun's absolute velocity in the plane of the ecliptic when performing observations of the eclipses of a Jovian satellite during 12 years in which the angle θ between v_s and the opposition line takes different values in the range of 360° , so that the difference $\delta t = \overline{\Delta t_0^n} - \Delta t_0^n$ will vary in the range $-(2Rv_s/c^2) \leq \delta t \leq (2Rv_s/c^2)$.

However, if we take into account the absolute kinematic time dilation (§11.1), we shall come to the conclusion that, if we measure the time on a terrestrial clock, then *no* positive effect can be registered.

Indeed, let us assume that the Earth covers the path $E_n E_0$ during the absolute time interval (read on a clock which rests in absolute space) Δt^n . The time Δt_0^n read on the proper terrestrial clock will be [use the second formula (3.25)]

$$\begin{aligned}
\Delta t_0^n &= \int_0^{\Delta t^n} \left[1 - \frac{(\mathbf{v}_E + \mathbf{v}_S)^2}{c^2} \right]^{1/2} dt \cong \left(1 - \frac{1}{2} \frac{v_E^2 + v_S^2}{c^2} \right) \Delta t^n - \\
&\quad - \int_0^{\Delta t^n} \frac{\Omega R v_S}{c^2} \cos \left(\frac{\pi}{2} - \theta + \Omega t \right) dt = \\
&= \left(1 - \frac{1}{2} \frac{v_E^2 + v_S^2}{c^2} \right) \Delta t^n + \frac{2 R v_S}{c^2} \cos \theta,
\end{aligned} \tag{15.6}$$

where v_E is the Earth's velocity with respect to the Sun, Ω is its angular velocity, and thus $v_E = \Omega R$.

Comparing formulas (15.5) and (15.6), we conclude that no positive effect can be registered in the quasi-Rømer experiment because the time interval between the zeroth and n th eclipses actually registered on a terrestrial clock will vary exactly in such a manner that the effect δt , which a traditional absolutist expects to be registered, will be compensated for by a change in the rate of the terrestrial clock.

§16. THE QUASI-BRADLEY EXPERIMENT

With the help of the Bradley experiment (i.e., the registration of the differences in the angles under which a given star is observed from the Earth during a year) for the second time in history the velocity of light was measured. If this experiment be performed with the aim of measuring the Earth's absolute velocity, we call it the **quasi-Bradley experiment**.

Now we shall show that the Earth's absolute motion can be revealed by the quasi-Bradley experiment. This problem is considered in detail in Marinov (1978j).

If we observe a star on the celestial sphere from a platform (the Earth) moving with an absolute velocity \mathbf{v} , then the relation between the emission angle θ' , which represents the angle between the velocity \mathbf{v} and the source-observer line at the moment of emission, and the reception angle θ , which represents the same angle at the moment of reception, will be [see formula (10.5)]

$$\left(1 + \frac{v}{c} \cos \theta' \right) \left(1 - \frac{v}{c} \cos \theta \right) = 1 - \frac{v^2}{c^2}. \tag{16.1}$$

Now suppose that our platform (the Earth) moves with velocity \mathbf{v}_E with respect to another platform (the Sun) which for its part moves with velocity \mathbf{v}_S respective to absolute space. Thus we have

$$\mathbf{v} = \mathbf{v}_E + \mathbf{v}_S. \tag{16.2}$$

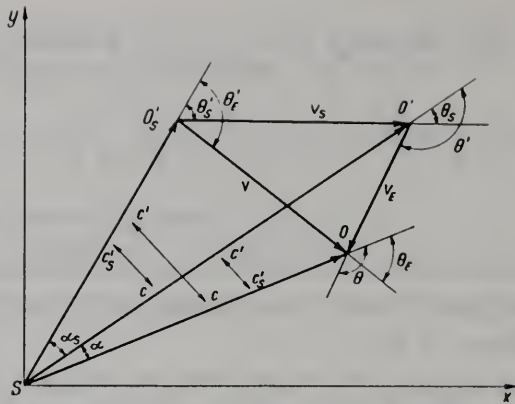

Fig. 16-1

Let us suppose that at the moment of emission an Earth's observer and an observer who rests with respect to the Sun (called the Sun's observer) are at the point O'_S (fig. 16-1). The light emitted at this moment by a star which is at the point S will be received by the Sun's observer when he crosses point O' and by the Earth's observer when he crosses point O . We have the following picture :

a) **Observation by the Sun's observer in absolute space.** For this case θ'_S is the emission angle and θ_S the reception angle, distance SO' is proportional to the absolute light velocity c and distance SO'_S to the relative light velocity with respect to the Sun c'_S .

b) **Observation by the Earth's observer in absolute space.** For this case θ'_E is the emission angle and θ_E the reception angle, distance SO is proportional to the absolute light velocity c and distance SO'_S to the relative light velocity with respect to the Earth c' .

c) **Observation by the Earth's observer in a frame attached to the Sun.** For this case θ' is the emission angle and θ the reception angle, distance SO is proportional to the relative light velocity with respect to the Sun c'_S (since this is the velocity of light which travels along the given direction with respect to a frame attached to the Sun) and distance SO' to the relative light velocity with respect to the Earth c' .

We must emphasize that we suppose all velocities (absolute and relative) to be measured in absolute time.

Consider now an *imaginable* emission which occurs at the moment when the Earth's observer is at the point O' and a reception which occurs at the moment when this observer arrives at the point O , the velocity of light being equal to c'_S . By analogy with (16.1) we have

$$\left(1 + \frac{v_E}{c'_S} \cos \theta'\right) \left(1 - \frac{v_E}{c'_S} \cos \theta\right) = 1 - \frac{v_E^2}{c'^2_S}, \quad (16.3)$$

where [see formula (10.11) and the text after formula (10.12)]

$$c'_S = c \left(\frac{1 - \frac{v_S}{c} \cos \theta_{Sm}}{1 + \frac{v_S}{c} \cos \theta_{Sm}} \right)^{1/2} \quad (16.4)$$

is the relative velocity of light in a frame attached to the Sun and θ_{Sm} is the middle angle between θ'_S and θ_S , i.e.,

$$\theta_{Sm} = \frac{\theta'_S + \theta_S}{2}. \quad (16.5)$$

Putting (16.4) into (16.3) and working within an accuracy of third order in $1/c$ (i.e., putting $\theta = \theta' = \theta_m$ in the terms of second and third order in $1/c$), we obtain

$$\cos \theta = \cos \theta' + \frac{v_E}{c} \sin^2 \theta_m \left(1 + \frac{v_S}{c} \cos \theta_{Sm}\right). \quad (16.6)$$

Designating by $\alpha = \theta' - \theta$ the aberration angle, we find within the necessary accuracy

$$\alpha = \frac{v_E}{c} \sin \theta_m + \frac{v_E v_S}{c^2} \sin \theta_m \cos \theta_{Sm} = \alpha_E + \Delta\alpha, \quad (16.7)$$

where α_E is the aberration angle caused by the motion of the Earth if the Sun were at rest in absolute space and $\Delta\alpha$ is the variation caused by the absolute velocity of the Sun, in dependence on the angle θ_{Sm} subtended by the light beam coming from the star and the velocity of the Sun.

In fig. 16-2 we have shown four different positions of the Earth (E_1, E_2, E_3, E_4) on its orbit around the Sun (S) at four different moments with intervals of three months when four different stars (S_A, S_B, S_C, S_D) are in range with the Earth in the plane of the ecliptic, if being observed from the Sun. The real positions of the stars S_A and S_C and their positions observed from the Sun coincide, since the angle θ_{Sm} between the Sun's velocity v_S and the propagation direction of the light coming from these stars is equal to π or to 0. The positions of the stars S_B and S_D observed from the Sun are tilted to an angle $\alpha_S = v_S/c$ with respect to their real positions, since for these two stars the angle θ_{Sm} is equal to $\pi/2$, i.e., they will be seen along the directions to S'_B and S'_D .

The star S_A will be observed from the Earth's positions E_i tilted to an angle $\alpha_E = v_E/c$, i.e., along the direction to S'_{A1} , if the Sun be at rest in

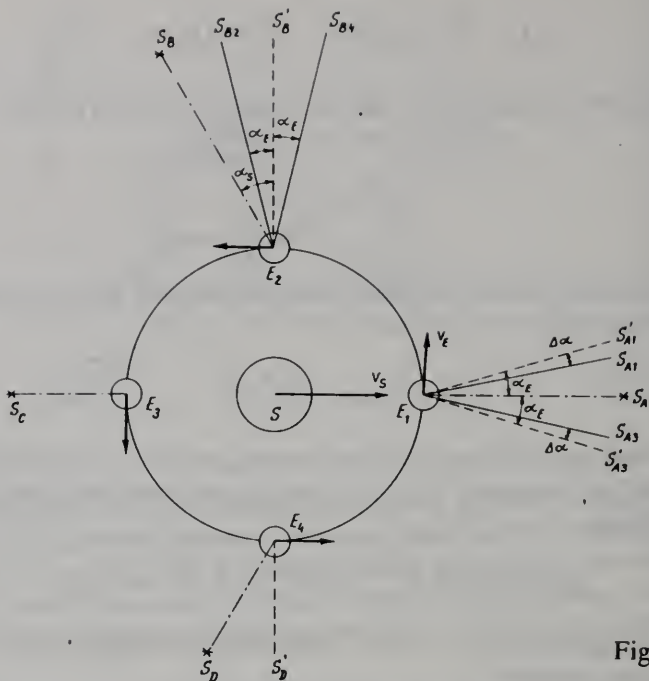

Fig. 16-2

absolute space and the velocity of light coming from S_A be equal to c . However, when the Sun moves and the velocity of light coming from S_A is $c + v_S$, this star will be seen from E_1 tilted to an angle

$$\alpha_{ap} = \alpha_E - \Delta\alpha = \frac{v_E}{c + v_S} = \alpha_E - \frac{v_E v_S}{c^2}, \quad (16.8)$$

i.e., along the direction to S_{A1} . The same star when observed from the position E_3 after six months will be tilted oppositely to the same angle α_{ap} , i.e., along the direction to S_{A3} . Thus in a year the stars which lie near the apex of the Sun should describe over the celestial sphere a small arc equal to $2\alpha_{ap} = 2\alpha_E - 2v_E v_S/c^2$. Analogously we conclude that the stars which lie near the Sun's anti-apex will describe a small arc equal to $2\alpha_{anti-ap} = 2\alpha_E + 2v_E v_S/c^2$. For the difference between these two arcs we obtain

$$\Delta = 2\alpha_{anti-ap} - 2\alpha_{ap} = 4\Delta\alpha = 4v_E v_S/c^2. \quad (16.9)$$

It can be seen immediately that the star S_B will be observed from the position E_2 tilted additionally to an angle $\alpha_E = v_E/c$, i.e., along the direction to S_{B2} and the same star will be observed after six months from the position

E_4 tilted oppositely to the same angle α_1 , i.e., along the direction to S_{B4} , both at rest and at motion of the Sun.

Taking $v_E = 30$ km/s, $v_S = 300$ km/s (see §19), we obtain $\Delta = 4 \cdot 10^{-7}$ rad = 0,08. Thus at the present state of technique, the quasi-Bradley experiment can be considered only as a challenge to the experimenters.

§17. THE QUASI-DOPPLER EXPERIMENT

Observing from the Earth during a year the differences in the frequencies of light emitted by a given star, one can measure the light velocity and we call this the Doppler experiment. If the Doppler experiment should be performed with the aim for the measurement of the Earth's absolute velocity, we call it the **quasi-Doppler experiment**.

Now we shall show that the Earth's absolute motion cannot be revealed by the quasi-Doppler experiment. This problem is considered in detail in Marinov (1978k).

Let us have (fig. 17-1) a distant light source (a star) S and two observers O_1, O_2 who rotate with relative velocities $\mathbf{v}_{r1}, \mathbf{v}_{r2}$ (it is $v_{r1} = v_{r2} = v_r$) about some centre C which for its part moves with an absolute velocity \mathbf{v} . The absolute velocities of O_1 and O_2 which lie on the same line with the centre of rotation are

$$\begin{aligned} v_1^2 &= v^2 + v_r^2 + 2 v v_r \cos \varphi, \\ v_2^2 &= v^2 + v_r^2 - 2 v v_r \cos \varphi, \end{aligned} \quad (17.1)$$

where φ is the angle between the velocity \mathbf{v} and the velocity of the first observer \mathbf{v}_{r1} . Denote by δ the angle between the source-observers line and the velocity \mathbf{v} at the moment of reception. Obviously δ is a constant angle, while φ changes with 2π during the period of rotation of O_1 and O_2 . All angles are taken positive clockwise and negative counter-clockwise.

Supposing that the source moves with velocity v_s and emits light with frequency ν , we obtain that an observer moving with velocity v_o will register a frequency ν_o given by the first formula (10.17) in which we have to write $\nu = \nu_s$. The angles θ' and θ_o can be seen in fig. 10-2. Writing in this formula first $\nu_o = \nu_1, v_o = v_1, \theta_o = \theta_1$, and then $\nu_o = \nu_2, v_o = v_2, \theta_o = \theta_2$ (see fig. 17-1) and dividing the formulas obtained, we get

$$\frac{\nu_1}{\nu_2} = \frac{1 - v_1 \cos \theta_1/c}{1 - v_2 \cos \theta_2/c} \left(\frac{1 - v_2^2/c^2}{1 - v_1^2/c^2} \right)^{1/2}. \quad (17.2)$$

Thus the relation between the frequency ν_1 received by the first observer and the frequency ν_2 received by the second observer does not depend on the velocity of the source v_s .

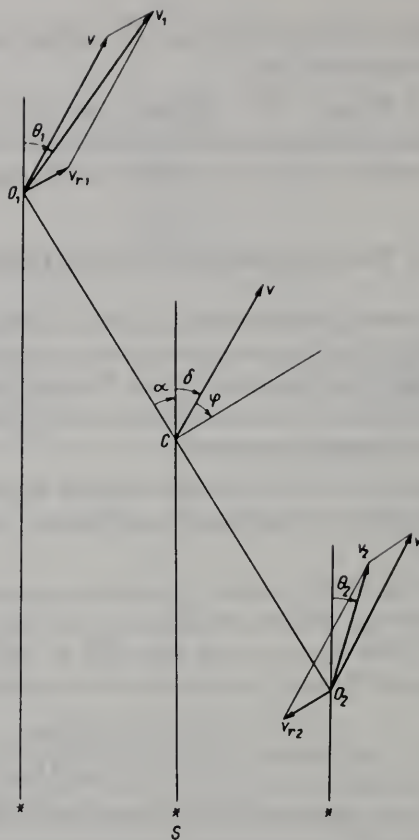

Fig. 17-1

From fig. 17-1 we have

$$\begin{aligned} v_1 \cos \theta_1 &= v \cos \delta + v_r \cos (\delta + \varphi), \\ v_2 \cos \theta_2 &= v \cos \delta - v_r \cos (\delta + \varphi). \end{aligned} \quad (17.3)$$

Substituting (17.1) and (17.3) into (17.2), we find within an accuracy of second order in $1/c$

$$\frac{\nu_1}{\nu_2} = 1 - 2 \frac{v_r}{c} \cos (\delta + \varphi) + 2 \frac{v v_r}{c^2} [\cos \varphi - \cos \delta \cos (\delta + \varphi)] + 2 \frac{v_r^2}{c^2} \cos^2 (\delta + \varphi) \quad (17.4)$$

This final expression is convenient for discussion. Let us measure ν_1 and ν_2 received from a given light (radio) source for which $\delta + \varphi = \pi/2$. If $\delta = 0$, it will be $\nu_1 = \nu_2$ for $\varphi = \pi/2$, however if $\delta = \pi/2$, it will be $\nu_1 = \nu_2 (1 + 2\nu v_r/c^2)$ for $\varphi = 0$. This result leads to the conclusion that we can

measure the Earth's absolute velocity in the following manner : Let us have two receivers placed at a parallel with 180° difference in the longitudes. Let us observe a radio source when it should « cross » the line O_1O_2 and let the frequencies received be sent to some middle point and there compared. Imagine for simplicity that this middle point is at the pole and that the Earth represents a flat disk. As we show in §30.4 when considering the so-called « rotor-rotor » experiment, if light is sent from the rim of a rotating disk to its centre, then the change in the frequency depends only on the rotational velocity, not on the velocity of the disk as a whole. Hence ν_1 and ν_2 when received at the pole will suffer equal changes, due to the daily rotation of the Earth. If now we compare ν_1 and ν_2 for different radio sources which « cross » the line O_1O_2 , then for $\delta = 0$ the frequencies ν_1 and ν_2 will be equal precisely at the moment when the radio source is on the line O_1O_2 , i.e., for $\delta + \varphi = \pi/2$, however for $\delta = \pi/2$ the frequencies ν_1 and ν_2 will be equal when [see (17.4) and take into account that for the case considered $\cos(\delta + \varphi) \cong 0$]

$$\cos(\delta + \varphi) = v/c. \quad (17.5)$$

Taking $v = 300 \text{ km/s}$ (§ 19), we obtain

$$\cos(\delta + \varphi) = \sin \alpha \cong \alpha = 10^{-3} = 3', 4, \quad (17.6)$$

where α is the angle between the line O_2O_1 and the source-observers line. Such an angle is large enough to be reliably registered. However, the angle α is *exactly* equal to the aberration angle due to the motion of the Earth with velocity v . This signifies that when the line O_2O_1 concludes an angle α with the source-observers line, the source *will be seen* along the direction O_1O_2 . Thus, because of the appearance of the aberration, the quasi-Doppler experiment leads practically to a null result.

§ 18. THE QUASI-FIZEAU « COUPLED-SHUTTERS » EXPERIMENT

The « coupled-shutters » experiment represents a modification of the historical Fizeau experiment for the measurement of the light velocity by a rotating cog-wheel with whose help the Earth's absolute velocity can be measured.

In the « coupled-shutters » experiment, we take into account only the *effects of first order in v/c* , so that even the traditional Newtonian kinematics leads to results adequate to physical reality. We consider this experiment in Marinov (1978f).

Let us have (fig. 18-1) two cog-wheels C_1 and C_2 fixed on a common shaft with length d which is set in rotation by the electromotor EM . Intensive

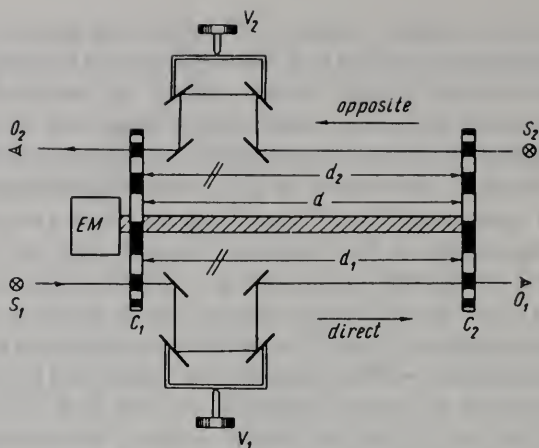

Fig. 18-1

light is emitted by the sources S_1 and S_2 . After passing through the notches of the cog-wheels C_1 and C_2 (respectively, C_2 and C_1), this light is observed by the observers O_1 and O_2 . We shall call the direction from S_1 to O_1 « direct » and from S_2 to O_2 « opposite ».

Suppose that the velocity of light in the « direct » and « opposite » directions is the same, equal to c . If both wheels have the same number of cogs placed respectively against each other (i.e., « cogs against cogs ») and they are set in rotation, then the observers will establish maximum photon fluxes in the case where the distance d between the wheels is covered by light in the same time that the wheels are rotated an integer number of notches. If any of the wheels has p notches and makes N revolutions per second, the wheels will rotate $f = pN$ notches in a second. We call this number, f , the frequency of chopping. Obviously, the condition for observing a maximum photon flux can be written

$$n = \frac{d}{c} f, \quad (18.1)$$

where n is an integer.

With the help of the verniers V_1 and V_2 we can change the paths d_1 and d_2 of the light beams between both wheels. If the velocity of light in « direct » and « opposite » directions is the same, then, obviously, O_1 and O_2 will observe maximum (or minimum) photon fluxes when $d_1 = d_2$.

Now suppose that the velocity of light is $c - v$ in the « direct » and $c + v$ in the « opposite » directions. The conditions for passing of the chopped « direct » and « opposite » beams will be

$$n_1 = \frac{d_1}{c - v} f, \quad n_2 = \frac{d_2}{c + v} f. \quad (18.2)$$

Assuming that, with a decrease of v towards zero, d_1 and d_2 should become equal to d , we shall have $n_1 = n_2 = n$, and, thus, we obtain

$$d_1 = d(1 - v/c), \quad d_2 = d(1 + v/c), \quad (18.3)$$

or

$$\Delta d = d_2 - d_1 = 2 \frac{d}{c} v. \quad (18.4)$$

Obviously, if we choose a lower chopping frequency a longer shaft must be used. It is easy to see that the chopping frequency which can be achieved by a rotating cog-wheel requires a steel shaft so long that practically it cannot be constructed. Thus the question may be posed about the use of two independent cog-wheels not fixed on a common shaft but rotating with the same angular velocity.

For the sake of generality, we shall now speak not of two independently rotating cog-wheels but of two independently operating pairs of shutters (for instance, Kerr cells). Any pair of these shutters (fig. 18-2) is driven by a common chopping mechanism, say, two resonators R_A and R_B .

Now the two following problems arise :

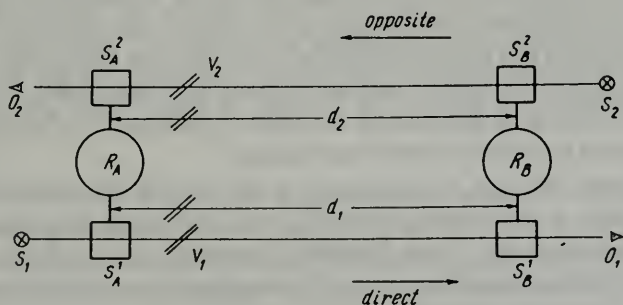

Fig. 18-2

a) How to maintain *equal* chopping frequencies for both pairs of shutters.

b) How to maintain a « phase difference » between them equal to zero, i.e., how to ensure that both pairs of shutters will close and open *together*.

The first difficulty can be overcome if we use the same resonator for both pairs of shutters, which can be put near the shutters S_A , near the shutters S_B , or in the middle. However, if we transmit the signals for opening and closing the shutters by an electric line, then a « phase difference » will appear between the pairs. It can easily be shown that the « phase difference », appearing at the motion of our apparatus in absolute space, will exactly cancel the effect that we intend to observe.

Hence the resonators producing the chopping frequency must be independent and for such, two atomic clocks can be taken. The chopping frequency f_B of the resonator R_B can be maintained equal to the chopping frequency f_A of the resonator R_A if we tune f_B in such a manner that the « beating » of the light spot observed by O_2 will always be reduced to zero.

When we use independent shutters, we cannot know the « phase difference » between them (i.e., we cannot know when the first pair of shutters is open, how far from opening is the second pair of shutters). Hence again we are unable to measure the absolute velocity v .

However, as Dart (1971) has suggested, one can rotate the apparatus with respect to absolute space. When the axis of the apparatus is perpendicular to v one will arrange the « phase difference » between both shutters so that both observers O_1 and O_2 would see no light. If now the apparatus is put parallel to v , so that the « direct » direction will coincide with the direction of v , then some light will be seen by the observers; and only if we change the distances d_1 and d_2 with the help of the verniers V_1 and V_2 to give a difference Δd according to formula (18.4), will no light be left to pass through both pairs of the coupled shutters.

However, taking into account the absolute time dilation, we can easily see that this prediction of Dart will not correspond to reality. Indeed, during the rotation both resonators will move at different velocities with respect to absolute space. Thus their time rates will be different and exactly such that the new « phase difference » that will appear after the rotation will *exactly cancel* the effect to be observed if the « phase difference » after the rotation had remained the same as before the rotation.

To prove this, let us suppose that the axis of the apparatus is first perpendicular to its absolute velocity. Let us then rotate the apparatus with angular velocity ω , say, about the middle point, until the « direct » direction of its axis becomes parallel to v . Let the readings of two clocks (suppose, for simplicity, light clocks) attached to R_A and R_B be t'_A, t'_B before the rotation and t''_A, t''_B after the rotation. Let the proper times $t_A = t''_A - t'_A, t_B = t''_B - t'_B$ correspond to the same absolute time interval t . Because of the absolute time dilation, we have [see the second formula (3.25)]

$$t_A = \int_0^t (1 - v_A^2/c^2)^{1/2} dt, \quad t_B = \int_0^t (1 - v_B^2/c^2)^{1/2} dt, \quad (18.5)$$

where

$$v_A^2 = v^2 + \left(\frac{d}{2}\omega\right)^2 - v d \omega \cos(\omega t), \quad (18.6)$$

$$v_B^2 = v^2 + \left(\frac{d}{2}\omega\right)^2 + v d \omega \cos(\omega t)$$

are the velocities of the resonators during the rotation of the apparatus.

If we work within an accuracy of second order in v/c , we obtain, after performing the integration, putting $\omega t = \pi/2$, and subtracting the second of formulas (18.5) from the first,

$$\Delta t = t_A - t_B = \frac{dv}{c^2}. \quad (18.7)$$

This formula shows that if before rotation the « phase difference » between both pairs of shutters is equal to zero, then after rotation the shutter S_B^1 will open with a delay Δt relative to the shutter S_A^1 , while the shutter S_A^2 will open with the same anticipation relative to the shutter S_B^2 . Thus for the same light paths, $d_1 = d_2$, minimum photon fluxes will pass through both coupled shutters.

Let us explain more clearly the difference between the independent shutters and the cog-wheels connected by a rigid shaft. The relations between the absolute time and the proper times elapsed on two clocks moving with velocities v_A and v_B are given by formulas (18.5) only if the clocks are independent. If we consider both rotating cog-wheels as clocks, we do not have the right to use formulas (18.5) because the wheels are *rigidly* connected by a common shaft and there is a *unique* clock — the motor driving the shaft, which, if placed at the middle, does not change its velocity during the rotation. Thus, after the rotation, a change in the « phase difference » between both cog-wheels cannot occur. If such a change appeared, then after the rotation *the shaft would be found to be twisted*, which, obviously, is nonsensical.

Thus the « coupled-shutters » experiment can « work » only when for shutters two cog-wheels fixed on a common shaft are used. In such a case a Newtonian time synchronization is realized, but the axis which one has to use to obtain a registrable effect must be so long that it cannot be practically constructed.

§ 19. THE QUASI-FOUCAULT « COUPLED-MIRRORS » EXPERIMENT

With the aim of shortening the basis in Fizeau's rotating cog-wheel experiment, Foucault developed his rotating mirror experiment. Our « coupled-mirrors » experiment represents a modification of this historical Foucault experiment with whose help for the first time in history we have measured the Earth's absolute velocity.

19.1. THE DEVIATIVE « COUPLED-MIRRORS » EXPERIMENT

In the summer of 1973 we carried out the deviative variant of the « coupled-mirrors » experiment. The report on its performance is given in Marinov (1974b).

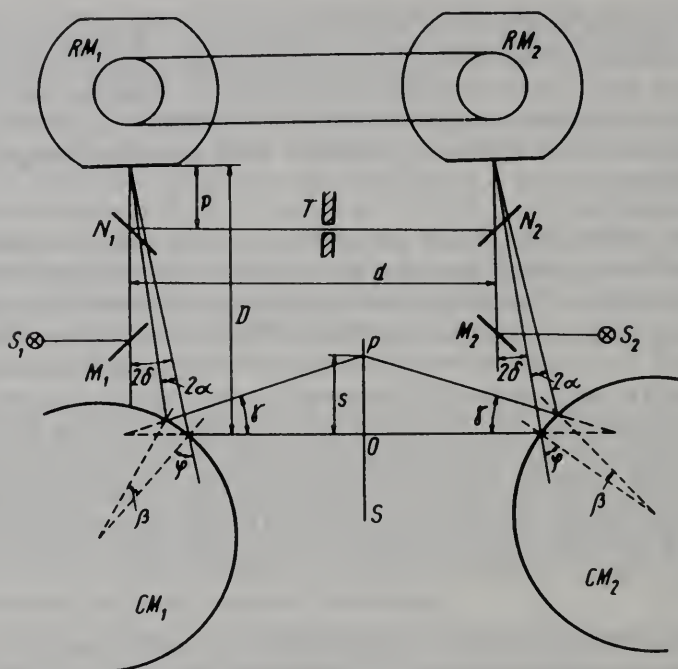

Fig. 19-1

In fig. 19-1 we give the scheme of this experiment. Let us have two disks driven always *exactly* with the same phase difference (imagine the wheels of a bicycle). On each disk two antipodal facets are cut and one is made a mirror, while the other and the rest of the disk's rim are not light reflecting. The distance between both disks, called the rotating mirrors RM_1 and RM_2 , is d . Intensive light from the source S_1 (or S_2) is reflected by the semi-transparent mirror M_1 (M_2) and, after passing through the semi-transparent mirror N_1 (N_2), is incident on the mirror facet of RM_1 (RM_2). The light beam then reflected by the semi-transparent mirrors N_1 and N_2 (N_2 and N_1) whose distance from the rotating mirror is p , is incident on the mirror facet of RM_2 (RM_1). If the rotating mirrors are at rest, the light beam reflected by the cylindrical mirror CM_2 (CM_1) will illuminate screen S from the right (from the left) at a certain point. The light path from the rotating mirrors to the cylindrical mirrors is D and from the cylindrical mirrors to the screen is $d/2$.

If the rotating mirrors are set in motion, then, because of the slit T , only the light which is reflected by RM_1 (RM_2) when the latter is perpendicular to the incident beam will reach RM_2 (RM_1). However, for the time spent by light to cover the distance $d + 2p$, the facet of RM_2 (RM_1) which is parallel (an exact parallelism is not necessary !) to the corresponding facet of RM_1 (RM_2) will rotate by a certain angle

$$\delta = \frac{d + 2p}{c} \Omega, \quad (19.1)$$

where Ω is the angular velocity of the rotating mirrors.

Suppose now that light velocity along the direction from RM_1 to RM_2 (which we call « direct ») is $c - v$ and along the direction from RM_2 to RM_1 (which we call « opposite ») is $c + v$. In such a case during the time in which the light pulse reflected by RM_1 will reach RM_2 the latter will rotate to an angle $\delta + \alpha$, while during the time in which the light pulse reflected by RM_2 will reach RM_1 , the latter will rotate to an angle $\delta - \alpha$, and we shall have

$$\delta \pm \alpha = \left(\frac{d}{c \mp v} + \frac{2p}{c} \right) \Omega, \quad (19.2)$$

from where (assuming $v \ll c$) we get

$$\alpha = \Omega d v / c^2. \quad (19.3)$$

Our apparatus takes part in the diurnal rotation of the Earth and in 24 hours it will make all possible angles with the component of the Earth's absolute velocity in the plane determined by the different positions of the apparatus during the day; this component we shall refer to as the Earth's absolute velocity and designate by v .

Suppose first that the unit vector along the « direct » direction n is perpendicular to v , and let us adjust the cylindrical mirrors so that the chopped light beams will illuminate the same point O on the screen S . Now, if n becomes parallel to v , both light beams will illuminate point P , and for the distance between O and P we shall have (suppose $\varphi = \pi/4$)

$$s = \gamma \frac{d}{2} + 2 \alpha D, \quad (19.4)$$

where $\gamma = 2(\alpha + \beta)$ and $\beta = 2\alpha(D/R) \sec \varphi$; angles β , γ , and φ are shown in fig. 19-1 and R is the radius of the cylindrical mirrors. Thus we have

$$s = \frac{\Omega}{c^2} d^2 v \left[1 + 2D \left(\frac{1}{d} + \frac{\sec \varphi}{R} \right) \right]. \quad (19.5)$$

The establishment of velocity v is to be performed as follows : In regular intervals of time during a whole day we maintain such a rotational velocity Ω

that the chopped light beam from the left will always illuminate point O . Then the light beam from the right will illuminate point O when n is perpendicular to v ; it will be displaced over a distance $2s$ upwards when $n \uparrow \uparrow v$ and over the same distance downwards when $n \uparrow \downarrow v$.

In our factual set-up, both rotating disks were fixed on a common shaft because the most important requirement of the « coupled-mirrors » experiment is the maintaining of an *equal phase difference* between both rotating mirrors during the Earth's rotation. Two He-Ne lasers were used as light sources. We used three cylindrical mirrors for each beam and such a combination of cylindrical mirrors which increases enormously the « arm » of a light beam is called by us the « cylindrical mirrors indicator ». The light spots were observed over two different screens because in our factual experiment both rotating mirrors lay in two different parallel planes. According to the calculation for our real adjustment it must be $s = 0,62$ mm for $v = 100$ km/s. This displacement is large enough to be reliably registered. However the inconstancy of the cylindrical mirrors radii and the trembling of the images were too considerable, and our experiment could not lead to an accurate quantitative measurement of v . The observed displacement was maximum 3 ± 2 hours after midnight and after noon and corresponded to a velocity $v = 130 \pm 100$ km/s, the « direct » direction being the one after midnight. The distance between both rotating mirrors was 7,2 m, the radius of the cylindrical mirrors was $R = 8$ cm, and the velocity of rotation of the shaft, taken from an old torpedo-boat, was $\Omega/2\pi = 80$ rev/s. The azimuth of the apparatus was 84° and the observations were performed in July-August in Sofia.

The error ± 100 km/s was established in the following manner: An observer maintained for 2-3 minutes one of the light spots in a certain position, adjusting by hand a corresponding tension of a *dc* electromotor which drives the shaft. Another observer registered the diapason of trembling of the other light spot which was normally 2-3 mm. If this diapason is $\Delta s = 2,48$ mm, then the fluctuation error is ± 100 km/s.

19.2. THE INTERFEROMETRIC « COUPLED-MIRRORS » EXPERIMENT

The result obtained with our deviative « coupled-mirrors » experiment was very inaccurate and the scientific community remained sceptical whether we really registered the Earth's absolute motion. For this reason, in the summer of 1975 we carried out the interferometric « coupled-mirrors » experiment, obtaining a very sure and reliable value for the Earth's absolute velocity. The report on its performance is given in Marinov (1978c).

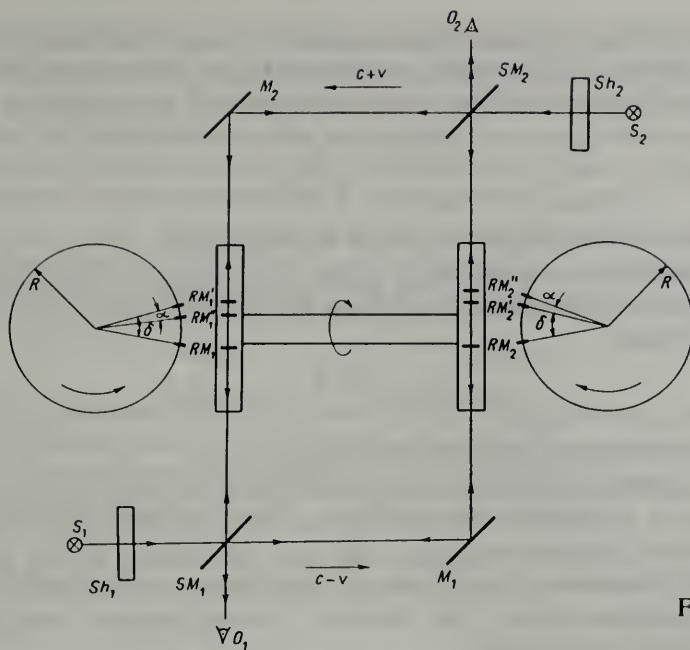

Fig 19-2

Let us have (fig. 19-2) a shaft with length d on whose ends there are two disks with radius R . On the rims of the disks, two mirrors RM_1 and RM_2 are fixed which we call the rotating mirrors. Monochromatic parallel light emitted by the source S_1 (or S_2) is partially reflected and partially refracted by the semi-transparent mirror SM_1 (SM_2). The « refracted » beam is then reflected successively by the mirror M_1 (M_2), by the rotating mirror RM_2 (RM_1), again by M_1 , SM_1 (M_2 , SM_2), and the observer O_1 (O_2) registers the interference which the « refracted » beam makes with the « reflected » beam, the last one being reflected by the rotating mirror RM_1 (RM_2) and refracted by SM_1 (SM_2). We call the direction from RM_1 to RM_2 « direct » and from RM_2 to RM_1 « opposite ».

Let us now set the shaft in rotation with angular velocity Ω and let us put in action the shutters Sh_1 and Sh_2 which should allow light to pass through them only when the rotating mirrors RM_1 and RM_2 are perpendicular to the incident beams. This synchronization is performed by making the opening of the shutters ($\cong 10^{-6}$ s) to be governed by the rotating shaft itself. Instead of shutters, we also used simple slits placed along the light paths to the rotating mirrors. If the « reflected » light pulse reaches RM_1 (RM_2) when the second mirror is in the position RM_2 (RM_1), then, in the case of rotating shaft, the « refracted » pulse will reach the second rotating mirror in the position RM_2' (RM_1') when the velocity of light is equal to c , and in the position RM_2'' (RM_1'')

(RM_1') when the velocity of light is equal to $c - v$ ($c + v$). Denoting by δ the angle between the radii of RM_2 and RM_2' (RM_1 and RM_1') and by α the angle between the radii of RM_2 and RM_2' (RM_1 and RM_1'), we shall have

$$\delta \pm \alpha = \frac{d}{c \mp v} \Omega, \quad (19.6)$$

from where (assuming $v \ll c$) we get the result (19.3).

The difference in the optical paths of the « refracted » and « reflected » light pulses in the cases of availability and non-availability of an « aether wind » will be

$$\Delta = 2 \alpha R = 2 \frac{d R \Omega}{c^2} v = 2 d \frac{v_r v}{c^2}, \quad (19.7)$$

where v_r is the linear velocity of the rotating mirrors.

If the wavelength of the used light is λ and we maintain such an angular velocity $\Omega = 2 \pi N$ (N is the number of revolutions per second) that the observer O_2 should always register the same interference picture, then, during the rotation of the apparatus over 360° in a plane parallel to the direction of the absolute velocity v , the observer O_1 should register a change in his interference picture within

$$z = 2 \frac{\Delta}{\lambda} = 8 \pi \frac{d R N}{\lambda c^2} v \quad (19.8)$$

wavelengths.

In our actual set-up, the « direct » beams are tangent to the *upper* parts of the rotating disks, while the « opposite » light beams are tangent to their *lower* parts. Thus the reflection of the « direct » and « opposite » beams proceeds on the same planes of the mirrors. The « observers » in our actual set-up represent two photoresistors which are put in the « arms » of a Wheatstone bridge. The changes in both interference pictures are *exactly opposite*. Thus in our apparatus the mirrors RM_1 and RM_2 are exactly parallel and the photoresistors are illuminated *not* by a pattern of interference fringes but *uniformly*.

A very important difference between the deviative and interferometric « coupled-mirrors » experiments is that the effect registered in the latter is *independent* of small variations in the rotational velocity. In the interferometric variant one *need not* keep the illumination over one of the photoresistors constant by changing the velocity of rotation v when rotating the axis of the apparatus about the direction of its absolute motion, but need merely to register the *difference* in the illuminations over the photoresistors during the rotation. This (together with the high resolution of the interferometric method) is the most important advantage of the interferometric « coupled-mirrors » experiment.

Since the illumination over the photoresistors changes with the change of the difference in the optical paths of the « refracted » and « reflected » beams according to the sine law, then the apparatus has the highest sensitivity when the illumination over the photoresistors is average (for maximum and minimum illuminations the sensitivity falls to zero). Hence a change in the velocity of rotation can lead only to a change in the sensitivity.

Let us consider this problem in detail. We suppose that the electric intensities of the « reflected » and « refracted » beams when they meet again on the semi-transparent mirror SM_1 (or SM_2) are, respectively,

$$E_1 = E_{\max} \sin(\omega t), \quad E_2 = E_{\max} \sin(\omega t + \varphi), \quad (19.9)$$

where E_{\max} is the maximum electric intensity which is equal for both beams, ω is the angular frequency of the radiation and φ is the difference between the phases of the intensities in the « reflected » and « refracted » beams.

The resultant electric intensity after the interference will be

$$E = E_1 + E_2 = 2 E_{\max} \sin\left(\omega t + \frac{\varphi}{2}\right) \cos \frac{\varphi}{2} = E_{\text{ampl}} \sin\left(\omega t + \frac{\varphi}{2}\right), \quad (19.10)$$

where $E_{\text{ampl}} = 2 E_{\max} \cos(\varphi/2)$ is the maximum electric intensity (the amplitude) of the resultant beam.

The energy flux density which will fall on the photoresistors will be

$$I = \frac{c}{8\pi} E_{\text{ampl}}^2 = \frac{c}{2\pi} E_{\max}^2 \cos^2 \frac{\varphi}{2} = I_{\max} \cos^2 \frac{\varphi}{2} = \frac{I_{\max}}{2} (1 + \cos \varphi), \quad (19.11)$$

where I_{\max} is the maximum possible energy flux density.

The sensitivity is

$$\frac{dI}{d\varphi} = -\frac{I_{\max}}{2} \sin \varphi \quad (19.12)$$

and is highest for $\varphi = \pi/2, 3\pi/2$, i.e., when the difference in the optical paths of the « reflected » and « refracted » beams is $(2n + 1)(\lambda/4)$, n being an integer. The sensitivity falls to zero for $\varphi = 0, \pi$, i.e., when this difference is $n(\lambda/2)$.

If the resistance of the photoresistors changes *linearly* with the change in the illumination (as was the case in our set-up), then to a small change dI in the energy flux density a change

$$dR = k dI = -k \frac{I_{\max}}{2} \sin \varphi d\varphi \quad (19.13)$$

in the resistance of the photoresistors will correspond, k being a constant. For a change $\Delta\varphi = \pi$ the resistance will change with $R = -k I_{\max}$, as it follows after the integration of (19.13).

Since it is $\Delta\varphi = 2\pi\Delta/\lambda$, then for $\varphi = \pi/2$, where the sensitivity is the highest, we shall have

$$\frac{\Delta R}{R} = \pi \frac{\Delta}{\lambda} . \quad (19.14)$$

Substituting this into (19.8), we obtain

$$v = \frac{\lambda c^2}{4 \pi^2 d R N} \frac{\Delta R}{R} . \quad (19.15)$$

The measuring method is : First, we make the axis of the apparatus to be perpendicular to the absolute velocity v of the laboratory. We set such a rotational rate N_1 that the illumination over the photoresistors to be minimum. Let us denote the resistance of the photoresistors under such a condition by R_1 and R_2 (it must be $R_1 = R_2$). We put the same constant resistances in the other two arms of the bridge, so that the same current J_0 (called the initial current) will flow through the arms of the photoresistors, as well as through the arms of the constant resistors, and no current will flow through the galvanometer in the bridge's diagonal. Then we set such a rotational rate N_2 that the illumination over the photoresistors is maximum and we connect in series with them two variable resistors, R , so that again the initial current, J_0 , has to flow through all arms of the bridge. After that we make the illumination average, setting a rotational rate $N = (N_1 + N_2)/2$, and we diminish correspondingly the variable resistors, R , so that again the same initial current has to flow through all arms of the bridge and no current through the diagonal galvanometer. Now, we make the axis of the apparatus parallel to the absolute velocity v and we transfer resistance ΔR from the arm where the illumination over the photoresistor has decreased to the arm where it has increased, so again the same initial current will flow through all arms and no current through the diagonal galvanometer. The absolute velocity is to be calculated from (19.15).

When the illuminations over the photoresistors were average a change $\delta R = 8 \cdot 10^{-4} R$ in any of the arms of the photoresistors (positive in the one and negative in the other) could be discerned from the fluctuation of the bridge's galvanometer and thus the resolution was

$$\delta v = \frac{\lambda c^2}{4 \pi^2 d R N} \frac{\delta R}{R} = \pm 17 \text{ km/s} . \quad (19.16)$$

The errors which can be introduced from the imprecise values of $d = 140$ cm, $R = 40,0$ cm, and $N = 120$ rev/s are substantially smaller than the resolution and can be ignored. To guarantee sufficient certainty we take $\delta v = \pm 20$ km/s.

The experiment was not performed in vacuum.

The room was not temperature-controlled, but it is easy to see that thermal disturbances cannot introduce errors because of the complete *symmetry* of the method and of its rapid performance.

The whole apparatus is mounted on a platform which can rotate in the horizontal plane and the measurement can be performed in a couple of seconds.

The magnitude and the apex of the Earth's absolute velocity have been established as follows :

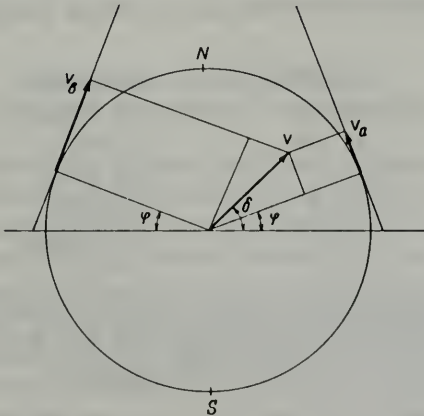

Fig. 19-3

During a whole day we search for the moment when the Wheatstone bridge is in equilibrium if the axis of the apparatus points east-west. At this moment the Earth's absolute velocity lies in the plane of the laboratory's meridian. Thus turning the axis of the apparatus north-south, we can measure v in the horizontal plane of the laboratory. The same is to be made after 12 hours. As can be seen from fig. 19-3, the components of the Earth's absolute velocity in the horizontal plane of the laboratory for these two moments are

$$v_a = v \sin(\delta - \varphi), \quad v_b = v \sin(\delta + \varphi), \quad (19.17)$$

where φ is the latitude of the laboratory and δ is the declination of the apex. From these we obtain

$$v = \frac{[v_a^2 + v_b^2 - 2 v_a v_b (\cos^2 \varphi - \sin^2 \varphi)]^{1/2}}{2 \sin \varphi \cos \varphi}, \quad (19.18)$$

$$\tan \delta = \frac{v_b + v_a}{v_b - v_a} \tan \varphi.$$

We take v_a and v_b as positive when they point to the north and as negative when they point to the south. Obviously, the apex of the absolute velocity points to the meridian of this component whose *algebraic* value is smaller. Thus we shall always assume $v_a < v_b$, and then the right ascension α of the apex will be equal to the local sidereal time of registration of v_a . We could establish this moment within a precision of about 30 minutes. Thus we can calculate (with an inaccuracy not larger than ± 5 min) the sidereal time t_{s1} for the meridian where the local time is the same as the standard time t_{st} of registration, taking into account that sidereal time at a middle midnight is as follows :

22 September	— 0 ^h	23 March	— 12 ^h
22 October	— 2 ^h	23 April	— 14 ^h
22 November	— 4 ^h	23 May	— 16 ^h
22 December	— 6 ^h	22 June	— 18 ^h
21 January	— 8 ^h	23 July	— 20 ^h
21 February	— 10 ^h	22 August	— 22 ^h

Our first measurement of the Earth's absolute velocity by the help of the interferometric « coupled-mirrors » experiment was performed on 12 July 1975 in Sofia ($\varphi = 42^\circ 41'$, $\lambda = 23^\circ 21'$). We registered

$$\begin{aligned} v_a &= -260 \pm 20 \text{ km/s}, & (t_{st})_a &= 18^h 37^m \pm 15^m, \\ v_b &= +80 \pm 20 \text{ km/s}, & (t_{st})_b &= 6^h 31^m \pm 15^m. \end{aligned} \quad (19.19)$$

Thus

$$v = 279 \pm 20 \text{ km/s},$$

$$\delta = -26^\circ \pm 4^\circ, \quad \alpha = (t_{st})_a = 14^h 23^m \pm 20^m. \quad (19.20)$$

We repeated the measurement exactly six months later on 11 January 1976 when the Earth's rotational velocity about the Sun was oppositely directed. We registered

$$\begin{aligned} v_a &= -293 \pm 20 \text{ km/s}, & (t_{st})_a &= 6^h 24^m \pm 15^m, \\ v_b &= +121 \pm 20 \text{ km/s}, & (t_{st})_b &= 18^h 23^m \pm 15^m. \end{aligned} \quad (19.21)$$

Thus

$$v = 327 \pm 20 \text{ km/s ,}$$

$$\delta = - 21^\circ \pm 4^\circ, \quad \alpha = (t_{st})_a = 14^h 11^m \pm 20^m. \quad (19.22)$$

For v and δ we have taken the r.m.s. error, supposing for simplicity $\varphi \cong 45^\circ$. The right ascension is calculated from the moment when v_a is registered, i.e., from $(t_{st})_a$, since for this case ($|v_a| > |v_b|$) the sensitivity is better. If our experiment is accurate enough, then t_{st} which is taken as the second must differ with $11^h 58^m$ from t_{st} which is taken as the first, because of the difference between solar and sidereal days.

The magnitude and the equatorial coordinates of the apex of the Sun's absolute velocity will be given by the arithmetical means of the figures obtained for the Earth's absolute velocity in July and January :

$$v = 303 \pm 20 \text{ km/s ,}$$

$$\delta = - 23^\circ \pm 4^\circ, \quad \alpha = 14^h 17^m \pm 20^m. \quad (19.23)$$

§ 20. THE ACCELERATED « COUPLED-MIRRORS » EXPERIMENT

Since the masses of the material points are a measure of their kinetic energy as well as of the gravitational energy to which they contribute, the so-called **principle of equivalence** can be formulated, this asserts : Any gravitational field in a small region around a given space point can be replaced by a suitable non-inertial frame of reference (and *vice versa*), so that the behaviour of material points in an inertial frame of reference in the presence of a gravitational field would be indistinguishable from their behaviour in a suitable non-inertial frame without the gravitational field.

Einstein generalized and made absolute this « mechanical » (or Galilean) principle of equivalence (as he has done with the Galilean principle of relativity — see §21), postulating that it is by no means possible to establish whether the acceleration which is exerted on material points in a laboratory has a kinematic (mechanic) character (thus being due to the accelerated motion of the laboratory, for example, by thrust of a space ship) or a dynamic (gravitational) character (thus being generated by the action of nearby masses, for example, by the Earth's attraction).

According to our absolute space-time conceptions, such a generalization of the principle of equivalence contradicts physical reality. The accelerated « coupled-mirrors » experiment proposed in Marinov (1978t) can immediately reveal the invalidity of Einstein's principle of equivalence. Its essence is as follows :

Let us measure with the help of our « coupled-mirrors » apparatus the absolute velocity of an accelerated laboratory at two different moments. If the acceleration is kinematic (mechanic), the absolute velocity in these two different moments will be different, however if the acceleration is dynamic (gravitational), the absolute velocity will always remain the same.

§ 21. THE ULTRASONIC « COUPLED-SHUTTERS » EXPERIMENT.

By the help of observations and logical generalizations, Galilei formulated the so-called **principle of relativity**, which asserts the following : The behaviour of a material system in two inertially moving frames of reference is identical; thus, performing measurements in a laboratory which moves inertially with respect to absolute space, one cannot establish this absolute motion.

Einstein assumed that this principle is valid also for light propagation (in general, for the electromagnetic phenomena) and generalized it for all physical phenomena, calling it the **general principle of relativity**. The principle of relativity which does not include light propagation phenomena was called the **restricted (or mechanical) principle of relativity**.

By the help of our « coupled-mirrors » experiment, we have shown that the general principle of relativity is invalid. However, no experiment exists which has contradicted the mechanical principle of relativity. In our absolute space-time theory, we consider the restricted principle of relativity as absolutely valid. *Moreover*, we have come to the conclusion that only by the combination of mechanical and light (electromagnetic) phenomena can one establish the absolute velocity of a laboratory. So, in our « coupled-mirrors » experiment the rotation of the shaft represents a mechanical phenomenon, and in a frame moving with respect to absolute space this rotation is independent of the axis' orientation. On the other hand, the propagation of light pulses represents an electromagnetic phenomenon, and in a moving frame it depends on the direction of propagation.

Briscoe (1958) has pointed to another combination of mechanical and electromagnetic phenomena which permits the registering of the absolute motion of a laboratory. Briscoe proposed the parallel transfer of light and sound signals. The propagation of sound is isotropic in any inertial frame, since this is a mechanical phenomenon, while the propagation of light is anisotropic, and, by comparing these two types of signal transfers, one can establish the absolute velocity of a laboratory.

We describe Briscoe's proposal in Marinov (1978u). Now, we give the description of a variant proposed by us in Marinov (1978s), which seems to be more reliable.

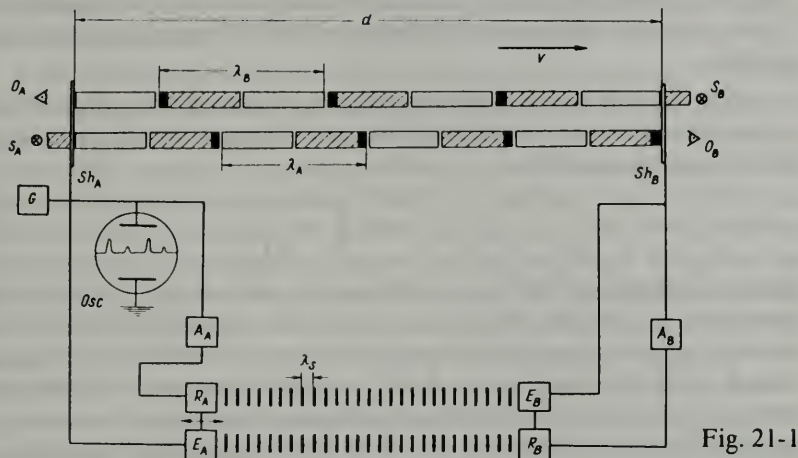

Fig. 21-1

Let us have (fig. 21-1) two electric high frequency operating shutters Sh_A , Sh_B , the distance between which is d . Behind the shutters there are the light sources S_A , S_B (lasers) and the observers O_A , O_B . The generator G produces electric pulses with period T (peak to peak time) which : (i) govern the shutter Sh_A , (ii) are applied to the emitter of ultrasonic waves E_A , (iii) are applied to the horizontal plates of the oscilloscope Osc . The ultrasonic pulses emitted by E_A with the same period T propagate through water at velocity V (thus their wavelength is $\lambda_s = VT$) and are received by the receiver R_B . After being transformed into electric pulses and amplified by the amplifier A_B , they : (i) are applied to the emitter of ultrasonic waves E_B , (ii) govern the shutter Sh_B . The ultrasonic pulses emitted by E_B propagate backwards in the water with the same velocity V and are received by the receiver R_A . After being amplified by the amplifier A_A , they are applied to the horizontal plates of the oscilloscope.

Let us suppose for simplicity the water homogeneous and the elements of the A -part (as well as of the B -part) very close to each other, so that the time in which the electric pulses cover the lines between shutters and ultrasonic emitter-receiver system can be ignored. In such a case we can affirm that when on the screen of the oscilloscope the emitted pulses (the high ones) coincide with the received pulses (the low ones) there is a whole number of

ultrasonic pulses along the track $E_A-R_B-E_B-R_A$. Moving the emitter-receiver system E_A-R_A back and forth we can change the number of pulses on that track.

The propagation of sound is a mechanical phenomenon and the principle of relativity holds good for it. Thus, by the help of sound signals, a Newtonian time synchronization between spatially separated points can be realized.

Suppose first that the absolute velocity of the laboratory (the Earth) is perpendicular to the axis d . The wavelengths of light in both directions will be $\lambda = cT$, and there will be

$$n = \frac{d}{\lambda} = \frac{d}{cT} \quad (21.1)$$

light pulses between the shutters Sh_A and Sh_B . Moving the emitter-receiver system E_A-R_A , we choose such a position that O_A and O_B should see an average light intensity. In such a case a half-integer number of sound waves is placed along the track $E_A-R_B-E_B-R_A$, and the low peaks will be exactly between the high peaks. In the real experiment, where the time lost by the pulses along the electric tracks cannot be ignored, the low peaks will have a certain position with respect to the high peaks.

Suppose now that the absolute velocity v becomes parallel to d , pointing from left to right, which direction we shall call « direct ». The light wavelength in the « direct » direction will become $\lambda_A = (c - v) T$ and in the « opposite » direction $\lambda_B = (c + v) T$, so there will be

$$n_A = \frac{d}{\lambda_A} = \frac{d}{(c - v) T}, \quad n_B = \frac{d}{\lambda_B} = \frac{d}{(c + v) T} \quad (21.2)$$

light pulses between the shutters Sh_A and Sh_B , respectively, in the « direct » and « opposite » directions.

If $\Delta n = n_A - n_B$ is less than (or equal to) $1/2$, the observer O_B will see the average light intensity plus a Δn th part of the maximum light intensity, while the observer O_A will see the average light intensity minus a Δn th part of the maximum light intensity. Thus for $\Delta n = 1/2$, O_B will see a maximum light intensity and O_A no light. If $\Delta n < 1/2$, we can reduce the time during which the shutters remain open to $\Delta n T$ (see the small segments shaded in black in the figure) obtaining that O_A will see no light, while O_B will see a $(2\Delta n)$ th part of the nominal maximum light intensity. (NB. Such will be the case if $d/\lambda = n + 3/4$, where n is an integer; if $d/\lambda = n + 1/4$, all will be *vice versa*).

From (21.2) we obtain

$$n_A = n_B \frac{c + v}{c - v} \cong n_B + 2 \frac{v}{c} n = n_B + \Delta n, \quad (21.3)$$

and making use of (21.1) we obtain for the absolute velocity

$$v = \frac{c \Delta n}{2 n} = \frac{c^2 T \Delta n}{2 d} . \quad (21.4)$$

Taking $f = 1/T = 0,3$ MHz (this frequency is used in the hydrolocators of Soviet submarines), $d = 50$ km, we obtain, for $v = 300$ km/s, $\Delta n = 0,1$.

In an actual experiment the water will not be homogeneous. Nevertheless, this is of no importance because the « direct » and « opposite » sound waves cross exactly the same way and the number of sound waves in the « direct » and « opposite » directions will be the same. However, as a result of different influences (temperature, density, currents, etc.), the water can change its sound conductive properties. This signifies that during different moments different numbers of sound waves will be placed along the tract $E_A-R_B-E_B-R_A$, and the low peaks will « creep » with respect to the high peaks. Thus throughout the experiment, a corresponding shift of the emitter-receiver system E_A-R_A is to be performed and the low peaks are to be maintained at their initial positions. If the « creep » of the low peaks is conspicuous, the experiment should be performed in winter when the water is covered by ice and preserves its sound conductive properties for long enough. This experiment will be successful if the low peaks can be maintained at their initial positions a whole day with an inaccuracy much less than one Δn th part of the period T . For convenience and higher accuracy the compensation of the « creep » is to be made not in the ultrasonic but in the electric tract.

If one can realize a stable multiplication of the frequency f and govern the shutters Sh_A, Sh_B by this enhanced frequency, then the absolute velocity v can be measured by changing the multiplication factor and by using a method similar to that used (and explained in detail) in §27, thus not waiting for the Earth's rotation.

§ 22. THE KINEMATIC TIME DILATION EXPERIMENTS

According to our absolute space-time theory the kinematic (Lorentz) time dilation is an absolute phenomenon (§11.1). Thus the comparison of the readings of clocks which move with different velocities with respect to absolute space can give information about these absolute velocities.

Indeed, if two clocks A and B move with the absolute velocities v_A, v_B , then the relation between their readings $\Delta t_A, \Delta t_B$ (i.e., proper time intervals) which correspond to the absolute time interval Δt read by an absolute clock will be [use formula (3.19)]

$$\frac{\Delta t_A}{(1 - v_A^2/c^2)^{1/2}} = \frac{\Delta t_B}{(1 - v_B^2/c^2)^{1/2}} \quad (22.1)$$

22.1. THE ROSSI-HALL « MESON » EXPERIMENT

The first experiment which proved the Lorentz time dilation was the so-called « meson » experiment performed by Rossi and Hall (1941). In this experiment the « clocks » were elementary particles, namely μ -mesons, and their « readings » were the mean lifetimes of the mesons.

The mean-life of μ -mesons at rest, i.e., the time in which $(1/e)$ th part of them will decay, is $T = 2.2 \cdot 10^{-6}$ s. Rossi and Hall measured the distance d covered by high-velocity μ -mesons produced near the top of the atmosphere as a result of nuclear interactions caused by primary cosmic radiation. Knowing their velocity v which is near to c , they calculated the proper mean-life T_0 of the mesons from the relation

$$T_0 = d/v. \quad (22.2)$$

Comparing T with T_0 , they have proved the relation (11.1).

A similar experiment for positive and negative muons in a circular orbit has been recently performed by Bailey *et al.* (1977) and has very reliably proved the relation (11.1).

22.2. THE HAFELE-KEATING « CLOCKS-ROUND-THE-WORLD » EXPERIMENT

The first experiment where the Lorentz time dilation was proved by the help of macroscopic clocks was the « clocks-round-the-world » experiment of Hafele and Keating (1972). It consisted of the following :

Two jet planes carrying atomic clocks left Washington in eastern and western directions, flew round the world and returned to the starting point. The readings Δt_E , Δt_W of the clocks carried by the eastern and western planes were compared with the reading Δt of a third atomic clock left in Washington.

In our treatment of this experiment we assume that both planes fly exactly along the parallel of Washington at the same height above sea level, at which height a stationary clock in Washington is also placed. The corrections which are to be made when the planes fly at different heights can be performed by taking into account the dynamic (Einstein) time dilation (§11.2). In the actual experiment the planes made many landings during the trip, thus changing their gravitational potentials, and the Hafele-Keating experiment proved *both* the Lorentz and Einstein time dilations.

In our treatment, we ignore the motion of the Earth around the Sun and their combined motion relative to absolute space because the *average* influence of all these motions on our clocks is the same. Thus we take into account only the rotational velocity of the Earth which leads to an asymmetry in the motion of the different clocks and which is

$$v_r = \frac{2\pi}{T} R \cos \varphi, \quad (22.3)$$

where R is the Earth's radius, φ is the latitude of Washington's parallel and T is the length of the sidereal day.

If we denote by v the velocity of the planes with respect to the Earth, then the east-bound clock which moves with velocity $v_E = v_r + v$ with respect to absolute space will be slow, while the west-bound clock which moves with velocity $v_W = v_r - v$ with respect to absolute space will be fast, and for the differences $\delta t_E = \Delta t_E - \Delta t$, $\delta t_W = \Delta t_W - \Delta t$, according to formula (22.1), we obtain within an accuracy of second order in $1/c$

$$\frac{\delta t_E}{\Delta t} = -\frac{2v v_r + v^2}{2c^2}, \quad \frac{\delta t_W}{\Delta t} = \frac{2v v_r - v^2}{2c^2}. \quad (22.4)$$

If we choose $\varphi = 43^\circ$ ($\cos 43^\circ = 0,730$) — that is the latitude of Washington — and if we take $T = 86.200$ s, $R = 6370$ km, we obtain $v_r = 340$ m/s. Of the same order is the commercial speed of the jet planes, so that we can suppose $v = v_r = 300$ m/s. Hence, under such simplified conditions, it is

$$\frac{\delta t_E}{\Delta t} = -\frac{3}{2} \frac{v^2}{c^2} = -15 \cdot 10^{-13}, \quad \frac{\delta t_W}{\Delta t} = \frac{1}{2} \frac{v^2}{c^2} = 5 \cdot 10^{-13}. \quad (22.5)$$

Hafele and Keating's planes did not fly strictly along the parallel of Washington, nor at the same height and they made many landings, the number of which were different for each plane. After taking into account the actual routes of the planes and the influence of the different gravitational potentials at different heights of the flights, Hafele and Keating calculated $\delta t_E = -59 \pm 10$ ns, $\delta t_W = 273 \pm 7$ ns, where the theoretical uncertainties come from imprecise knowledge of the routes. The experimentally measured differences were $\delta t_E = -40 \pm 23$ ns, $\delta t_W = 275 \pm 21$ ns.

We direct the reader to the recent paper by Briatore and Leschiutta (1976) who claim to have experimentally proved the Lorentz and Einstein time dilations, after comparing for a couple of years the readings of atomic clocks placed at different points on the Earth which have different absolute velocities (because of the different latitudes) and different gravitational potentials (because of the different heights above the sea level of the stations and the not exactly spherical form of the Earth).

22.3. THE « ANTIPODAL-CLOCKS » EXPERIMENT

The essence of this experiment with whose help one can measure the absolute velocity of a laboratory was proposed by Marinov (1972b) and it was considered in detail in Marinov (1978l).

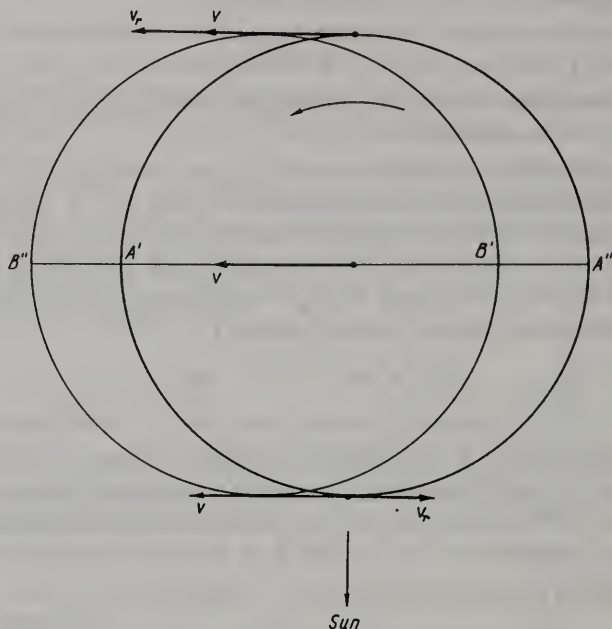

Fig. 22-1

Let us have two atomic clocks placed at two antipodal points of the Earth's equator (see fig. 22-1, where we have shown the Earth as seen from the north celestial pole). Let the Earth's absolute velocity be v and the linear rotational velocity of the equator be v_r . Suppose for the sake of simplicity that the Earth's axis is perpendicular to the plane of the ecliptic and that we consider such a day of the year when the absolute velocity of the Sun (or at least its component in the plane of the ecliptic) v_s is parallel to the velocity of the Earth about the Sun v_E . Taking the initial zero moment when it is sunrise for the first atomic clock (clock A) and sunset for the second atomic clock (clock B), we shall have for the absolute velocities of these clocks, respectively,

$$v_A^2 = v^2 + v_r^2 - 2 v v_r \sin \frac{2 \pi t}{T}, \quad (22.6)$$

$$v_B^2 = v^2 + v_r^2 + 2 v v_r \sin \frac{2 \pi t}{T},$$

where $v = v_s + v_E$, and T is the length of the sidereal day.

If we use these formulas in (22.1), we see that the rates of our clocks will be different at different hours of the day. The greatest difference will be when for one clock it is noon and for the other midnight, and only during the sunset and sunrise hours will these rates be equal. If we compare the readings of our clocks for *equal absolute intervals of time* between sunset and sunrise, we should establish the absolute character of the Lorentz time dilation and we could measure the Earth's absolute velocity. This represents the essence of the « antipodal-clocks » experiment.

However, a realization of Newtonian time synchronization between two antipodal points on the Earth is problematic and later we shall show that a realization of time synchronization by the exchange of electromagnetic signals, i.e., of Einsteinian time synchronization, leads to an annihilation of the appearing absolute effects. For this reason the « antipodal-clocks » experiment is to be performed on a turnabout, as shown in fig. 22-2.

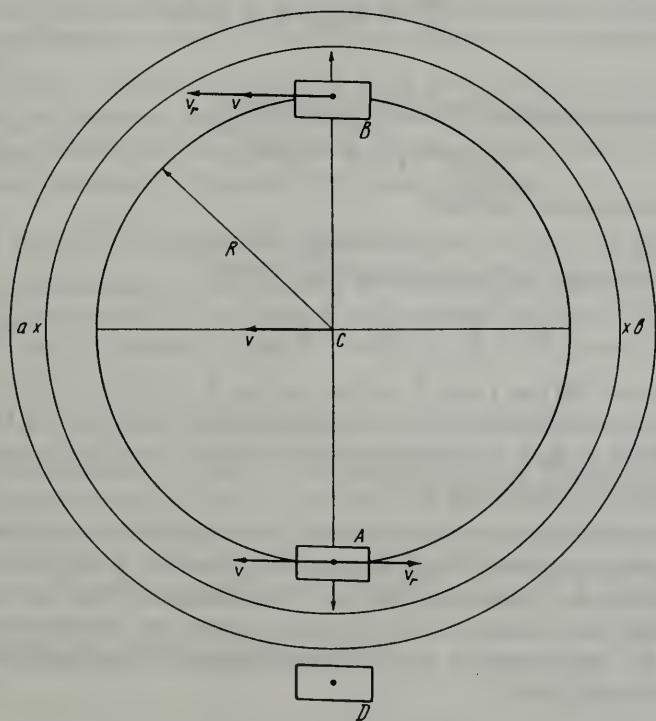

Fig. 22-2

Let us have a ring ab which encircles the turnabout but does not rotate with respect to absolute space. Suppose that points a and b lie on a diameter which is parallel to the absolute velocity v . Let the readings t'_A, t'_B be

registered on clock A when it touches, respectively, points a , b , and let the readings t'_b , t'_b be registered on clock B when it touches, respectively, points b , a .

The times $\Delta t_A = t'_A - t'_A$ and $\Delta t_B = t'_B - t'_B$ obviously correspond to the same absolute time interval which we shall denote by Δt . It is

$$\Delta t = \Delta t_D (1 - v^2/c^2)^{-1/2}, \quad (22.7)$$

where Δt_D is the time read on a clock D which does not rotate.

On the grounds of formula (22.1) we can write

$$\Delta t = \int_0^{\Delta t_A} (1 - v_A^2/c^2)^{-1/2} dt, \quad \Delta t = \int_0^{\Delta t_B} (1 - v_B^2/c^2)^{-1/2} dt. \quad (22.8)$$

Substituting here v_A , v_B from (22.6) and working within an accuracy of second order in $1/c$, we obtain

$$\Delta t_A \left(1 + \frac{1}{2} \frac{v^2 + v_r^2}{c^2} - \frac{2}{\pi} \frac{v v_r}{c^2}\right) = \Delta t_B \left(1 + \frac{1}{2} \frac{v^2 + v_r^2}{c^2} + \frac{2}{\pi} \frac{v v_r}{c^2}\right), \quad (22.9)$$

having taking into account that approximately it is

$$\Delta t_A \cong \Delta t_B \cong \Delta t = T/2, \quad (22.10)$$

where T is the period of rotation.

Denoting $\delta t = \Delta t_A - \Delta t_B$ and taking into account (22.10) only in the terms of second order in $1/c$, we obtain from (22.9)

$$\delta t = \frac{4}{\pi} \frac{v v_r}{c^2} \Delta t = 4 \frac{v R}{c^2}. \quad (22.11)$$

Taking $v = 300$ km/s and $R = 3$ m, we find $\delta t = 4 \cdot 10^{-11}$ s. Supposing that the revolutions per second of the turnabout are 5 (i.e., $\Delta t = 0,1$ s), we shall have $\delta t/\Delta t = 4 \cdot 10^{-10}$, while the portable cesium beam clocks show the time with a relative inaccuracy $\pm 10^{-13}$.

Now we shall show that the realization of an Einsteinian time synchronization in the « antipodal-clocks » experiment leads to a negative (null) result because of the mutual annihilation of the absolute effects and thus in such a manner the absolute velocity of the laboratory (the Earth) cannot be measured. We shall consider the « antipodal-clocks » experiment on the rotating Earth (fig. 22-1).

Let clock A send the initial electromagnetic signal being at point A' (i.e., when for this clock it is sunrise) and let its reading at this moment be t'_A . Since the light signal travels a certain time, clock B will move with the Earth and will receive the signal being at point B' . Here we do not take into account the

rotation of the Earth because in the case considered the linear rotational velocity v_r is perpendicular to the translational velocity v , and, as it can be shown, the effects calculated, if taking into account the velocity v_r , will be cancelled in the final result.

For the sake of simplicity we suppose also that the electromagnetic signal propagates along the Earth's diameter, whose length is d . It can be shown that if the signal covers a trajectory along the Earth's surface (a radio-relay tract), then the effects calculated additionally will be cancelled in the final result.

With respect to absolute space the initial signal will cover the following distance

$$d' = d(1 - v/c), \quad (22.12)$$

which we calculate within an accuracy of first order in v/c because, as we shall see further [formula (22.15)], a higher accuracy is not necessary.

Clock A sends the final signal at point A'' (i.e., when for this clock it is sunset), and let its reading at this moment be t''_A . Clock B will move with the Earth and will receive the signal being at point B'' . With respect to absolute space the final signal will cover the following distance

$$d'' = d(1 + v/c). \quad (22.13)$$

Let us denote by t'_B the reading of clock B when clock A has sent the initial signal and by t''_B the reading when clock A has sent the final signal. Making use of formulas (22.8), (22.9) and (22.10), we can write

$$t''_A - t'_A = (t''_B - t'_B) \left(1 + \frac{4}{\pi} \frac{v v_r}{c^2}\right) = t''_B - t'_B + 2 \frac{d v}{c^2}. \quad (22.14)$$

If we denote by T'_B and T''_B the readings of clock B when the initial and final signals, respectively, have been received, then, using (22.12) and (22.13), we obtain

$$t'_B = T'_B - \frac{d}{c} \left(1 - \frac{v}{c}\right), \quad t''_B = T''_B - \frac{d}{c} \left(1 + \frac{v}{c}\right). \quad (22.15)$$

Putting (22.15) into (22.14), we find

$$t''_A - t'_A = T''_B - T'_B, \quad (22.16)$$

and, obviously, from this relation between the readings of clock A when the initial and final signals are sent and the readings of clock B when these signals have been received we cannot establish the absolute velocity v .

Now we shall propose a variant of the « antipodal-clocks » experiment with whose help the equatorial component of the Earth's absolute velocity can be measured.

Let us have two passage instruments at a point on the Earth's equator whose *fixed axes* lie in a vertical plane parallel to the east-west direction, the angle between them being θ . Suppose that an equatorial star A , which lies about 90° from the projection on the celestial equator of the apex of the Earth's absolute velocity, crosses the sight line of the first telescope at the moment t'_A , read on an exact clock, and the sight line of the second telescope at the moment t''_A . Let us further suppose that a star B which is antipodal to the first one crosses the sight line of the first telescope at the moment t'_B and the sight line of the second telescope at the moment t''_B .

Since the Earth rotates uniformly, the times $\Delta t_A = t''_A - t'_A$ and $\Delta t_B = t''_B - t'_B$, obviously, correspond to the same absolute time interval Δt , and we can use formulas (22.8), where v_A and v_B are given by formulas (22.6). Thus, assuming for simplicity $\theta = \pi$, introducing the notation $\delta t = \Delta t_A - \Delta t_B$, and performing an analysis as above, we shall obtain the result (22.11). Taking $v = 300$ km/s, $R = 6370$ km, we get $\delta t = 8.5 \cdot 10^{-5}$ s.

If a similar experiment be performed throughout a year, using as a « rotating disk » not the diurnal rotation of the Earth about its axis but the yearly revolution around the Sun, then in formula (22.11) we have to take for v the component of the Sun's absolute velocity in the plane of the ecliptic and for R the radius of the Earth's orbit. Taking $v = 300$ km/s and $R = 150 \cdot 10^6$ km, we obtain $\delta t = 2$ s. It is very instructive to compare the analysis of this experiment with the analysis of the quasi-Rømer experiment (§15).

§ 23. THE « WATER-TUBE » EXPERIMENT

In Marinov (1978i), we reconsider the historical « water-tube » experiment of Fizeau (1851) which was repeated by Zeeman (1914) with the aim of establishing the Doppler-effect influence on the drag of light. In that paper, which will now be reviewed, we have shown that the formula proposed by Lorentz and Einstein for the drag of light in a moving medium is not true and we have given the true formula, verifying it by a very careful repetition of the « water-tube » experiment (see also §28).

The essence of the « water-tube » experiment is as follows :

Let us have a tube with length L along which water propagates with velocity v . We generate two light pulses at the same moment and let them go through this tube, so that one pulse (called « direct ») travels with the flow of

the water and the other (called « opposite ») against it. Suppose that both pulses cover paths with the same lengths and meet again. Obviously, if the water is at rest, they will arrive at the same moment. However, if the water is in motion, the pulse travelling against the flow will be late for the rendezvous, the time delay being

$$\Delta t = \frac{L}{c_m^-} - \frac{L}{c_m^+} = \frac{2L\nu}{c^2} (n^2 - 1), \quad (23.1)$$

where we have used formula (13.12) for $\theta_0 = 0, \pi$, working within an accuracy of first order in ν/c .

Here n is the refractive index of water for the frequency ν of the used monochromatic light. However, since the molecules of the liquid move with respect to the light source, a Doppler effect occurs and the water molecules will receive photons with a frequency

$$\nu_0 = \nu (1 \pm \nu/c), \quad (23.2)$$

where the sign « + » is for the « opposite » photons and the sign « - » is for the « direct » photons.

A Taylor expansion of the refractive index as a function of ν yields

$$n(\nu_0) = n(\nu) \pm \frac{dn}{d\nu} d\nu = n \pm \frac{\nu}{c} \nu \frac{dn}{d\nu}. \quad (23.3)$$

Thus putting (23.3) into (13.16) for $\theta = 0, \pi$, we obtain for the velocity of photons in flowing water, taking into account the dispersion (and within an accuracy of first order in ν/c),

$$c_m = \frac{c}{n} \pm \nu \left(1 + \frac{\nu}{n^2} \frac{dn}{d\nu} - \frac{1}{n^2} \right). \quad (23.4)$$

For the time delay instead of (23.1) we have

$$\Delta t = \frac{2L\nu}{c^2} \left(n^2 - \lambda \frac{dn}{d\lambda} - 1 \right), \quad (23.5)$$

where λ is the wavelength of the emitted light.

Lorentz (1916) and Einstein (1914) give for the time delay in the « water-tube » experiment the following formula

$$\Delta t = \frac{2L\nu}{c^2} \left(n^2 - n\lambda \frac{dn}{d\lambda} - 1 \right). \quad (23.6)$$

These authors come to formula (23.6) proceeding not from the relation (23.2) but from the following relation

$$\nu_0 = \nu \left(1 \pm \frac{\nu}{c/n} \right). \quad (23.7)$$

Their argument is the following : When the photons enter the water tube they first meet water molecules at rest and the frequency received by these shield molecules will be equal to the emitted frequency ν . Thus in the « water-tube » experiment there is a Doppler effect for light « emitted » by water molecules at rest and then « received » by the moving water molecules. However, according to these authors, the velocity of light in a medium is c/n and not c .

According to our « hitch-hiker » model (§13), the photons move only in vacuum and always with velocity c . One measures velocity c/n in a medium only because for a certain time the photons are hitched to the molecules and c/n is their average velocity.

Formula (23.5) is obtained also by Lorentz (1916) and Einstein (1914) but only for the drag of light in moving solids. Thus they make a substantial difference between the propagation of light in a liquid flowing in tubes and in moving bulk materials. For our theory there are only molecules, vacuum and photons (free or hitched); and a Doppler effect always appears when the « emitting » and « receiving » molecules move with different velocities.

With the aim of establishing which « drag-of-light » formula corresponds to physical reality we have repeated (Marinov, 1978i) the « water-tube » experiment, using our very sensitive bridge method for measurement of interference shifts (see §19.2).

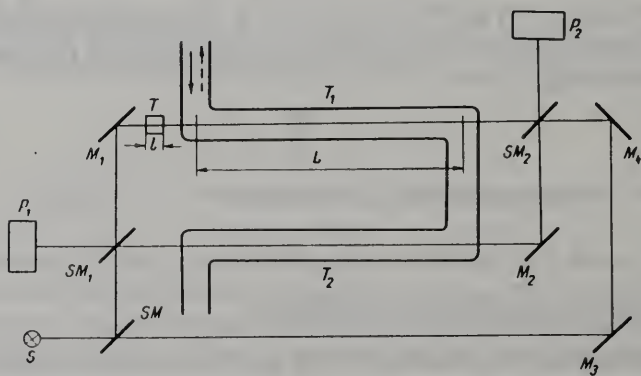

Fig. 23-1

Our experimental arrangement was as follows (fig. 23-1) : Light emitted by the source S is split by the semi-transparent mirror SM into two beams. The beam reflected by SM is split additionally by the semi-transparent mirror SM_1 into two daughter beams : the beam refracted by SM_1 , after reflecting on mirror M_1 , proceeds through the tube T_1 , while the beam

reflected by SM_1 , proceeds through the tube T_2 and, after reflecting on mirror M_2 , meets again the beam which has crossed T_1 at the semi-transparent mirror SM_2 . These two beams interfere and illuminate *uniformly* the photoresistor P_2 which is in one arm of a Wheatstone bridge.

The situation is similar in the case of the beam refracted by SM . It splits also into two daughter beams at SM_2 which meet together at SM_1 and, interfering there, illuminate also *uniformly* the photoresistor P_1 put in the other arm of the Wheatstone bridge.

The method of measurement is as follows :

When the water is at rest the illuminations over P_1 and P_2 must be equal, since the phase differences between the daughter beams in any pair are exactly the same. If we now set the water in motion, so that it flows in tube T_1 from left to right and in tube T_2 from right to left, the illuminations over P_1 and P_2 will begin to change oppositely. With the increase in the water's velocity, the bridge comes into greater and greater disequilibrium, passes through a maximum disequilibrium, and when the path difference $\Delta = \Delta_1 + \Delta_2$ (where Δ_1 is the change in the difference between the light paths of the daughter beams propagating from left to right and Δ_2 is the change in the difference between the light paths of the daughter beams propagating from right to left) will become equal to λ the bridge comes again into equilibrium. Thus we can verify formulas (23.1), (23.5) and (23.6), writing there $\Delta = c\Delta t = \lambda$.

The sensitivity of the method depends on the sum of the differences in the light paths of the beams going through T_1 and T_2 when the water is at rest. If this sum is exactly equal to $n\lambda$ (here n is an integer), then no disequilibrium of the bridge will be achieved when increasing the velocity of water. If this sum is equal to $(2n + 1)(\lambda/2)$, then the sensitivity of the bridge is the highest.

We search for a maximum sensitivity by changing the temperature of the « tuner » T which represents a small piece of glass. Its length is $l = 1$ cm and the temperature rate of its refractive index is about $dn/dT = 5.10^{-6}$ 'degree⁻¹. Changing its temperature in the range of 6° C, we change the light paths of the beams proceeding through T and T_1 by 300 nm. The temperature of T can be thermostabilized within $\delta T = \pm 0,04$ C, so that we can maintain the light path through T and T_1 constant in the limits of $\delta\Delta = \pm 2$ nm. The water is circulated from a reservoir where it is thermostabilized at a temperature $20^\circ \pm 0,3$ C.

Maximum sensitivity can be established and maintained in the following way : Changing the temperature of the tuner T we change the level of illumination over P_1 and P_2 from minimum (when the current in the arms of

P_1 and P_2 is J_{\min}) to maximum (when the current in the arms of P_1 and P_2 is J_{\max}). If additional resistances R , put in any of the arms of P_1 , P_2 , will reduce the current in the last case to J_{\min} , then we put resistances $R/2$ in any of the arms of P_1 , P_2 , and by changing the level of illumination over them (by the help of the tuner T) we adjust the current to be J_{\min} . At this condition the sensitivity is highest and the temperature of T must be maintained so that current J_{\min} always has to flow through the arms of P_1 and P_2 . It is expedient to always maintain the current in the diagonal galvanometer (the zero galvanometer) equal to zero, transferring resistance from the arm of P_1 into the arm of P_2 (and *vice versa*) when changing the velocity of the water. The maximum sensitivity of the bridge is $\delta\Delta = \pm 2,5 \cdot 10^{-4} \lambda$, since the fluctuations of the zero galvanometer are about 4000 times smaller than the current $J_{\max} - J_{\min}$.

The lengths of the tubes T_1 and T_2 are $L = 262,0 \pm 0,5$ cm, if measured as shown in the figure. The manometer was calibrated with a precision $\delta v/v = \pm 4 \cdot 10^{-3}$. The values for n and $dn/d\lambda$, corresponding to the different wavelengths, are taken from a graph which we have plotted on the basis of the data given in Landolt-Börnstein (1962). The inaccuracies estimated by us are, respectively, $\delta n/n = \pm 2 \cdot 10^{-4}$ and $\delta(dn/d\lambda)/(dn/d\lambda) = \pm 5 \cdot 10^{-3}$.

The light source is a tuned dye laser with neodymium glass oscillator. The inaccuracy in the chosen wavelengths is $\delta\lambda/\lambda = \pm 10^{-3}$.

TABLE 23-1

λ nm	n	$dn/d\lambda$ mm ⁻¹	v m/s	k
236	1,3850	— 662	6,30	0,99
250	1,3770	— 516	6,98	1,00
280	1,3644	— 310	8,44	1,01
300	1,3586	— 242	9,36	0,99
360	1,3476	— 130	11,96	0,98
390	1,3438	— 108	13,16	1,01

In table 23-1 we give the used wavelengths λ , the corresponding values for n and $dn/d\lambda$, the registered velocities v and the calculated values of the factor

$$k = \frac{1}{\lambda (dn/d\lambda)} \left(n^2 - 1 - \frac{c \Delta}{4 L v} \right), \quad (23.8)$$

where we have to put $\Delta = c\Delta t = \lambda$.

It must be $k_L = 0$, $k_M = n$, $k_N = 1$, according to the Fresnel, Lorentz and Marinov formulas (23.1), (23.6) and (23.5). Taking into account all possible sources of errors, we obtain $\delta k/k = \pm 0,10$, for $\lambda = 300$ nm.

§ 24. THE « DRAG ABERRATION » EXPERIMENT

In Marinov (1978m) we have pointed to an effect we call the **drag aberration**, which will now be analysed.

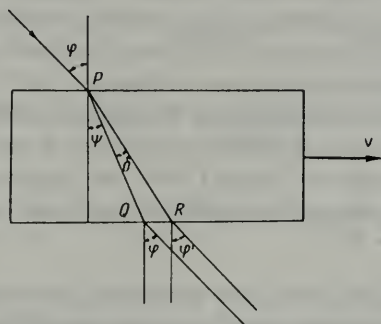

Fig. 24-1

Let us have (fig. 24-1) a transparent medium with parallel surface planes on which a light beam is incident under an angle φ at a point P . If the angle of refraction is ψ , the beam will leave the medium at a point Q under an angle φ equal to the angle of incidence.

Let the medium now be set in motion with velocity v from left to right — imagine that the medium is represented by a horizontal disk which rotates about a vertical axis and the light beam strikes it somewhere near the rim. Now the light beam will leave the medium at a particular point R . We call the angle $\delta = \angle QPR$ the **drag angle** (or the **drag aberration**).

We shall find the drag angle, proceeding from our « hitch-hiker » model for light propagation, and perform all calculations within an accuracy of first order in v/c .

Formula (13.16) shows that, within an accuracy of first order in v/c , the velocity of light in a moving medium represents a vector sum of the velocities c/n and $v(1 - 1/n^2)$, θ being the angle between them.

Taking into account that the photons cross the medium for a time

$$t = \frac{PQ}{c/n} = \frac{dn}{c \cos \psi}, \quad (24.1)$$

where d is the thickness of the medium, we obtain for the resultant distance QR along which the photons will be dragged

$$QR = v \left(1 - \frac{1}{n^2}\right) t = \frac{d v}{c \cos \psi} \left(n - \frac{1}{n}\right). \quad (24.2)$$

Thus the drag angle will be

$$\delta = \frac{QR \cos \psi}{PQ} = \frac{v}{c} \left(n - \frac{1}{n}\right) \cos \psi. \quad (24.3)$$

Formula (24.3) can be easily verified experimentally by silvering the parallel planes of the medium, making them light reflecting, so that the beam has to undergo a high number of reflections before leaving the medium. By the help of our « cylindrical mirrors indicator » (§19.1), the appearing drag aberration can be reliably registered. We call such an experiment the « drag aberration » experiment. Recently it was carried out by Jones (1975) and considered theoretically by Player (1975) and Rogers (1975); however, the experiment and the theoretical considerations have been made *only for the special case* $\varphi = \psi = 0$.

Player and Rogers made their analysis by proceeding from the Lorentz transformation and without referring to the physical model of light propagation in a medium, as one does in conventional physics when solving all problems about light kinematics in a moving medium.

We shall show the results deriving from such an automatic implication of the Lorentz transformation to the drag aberration for the general case of $\varphi \neq 0$. Let us attach (fig. 24-1) a moving frame K' to the medium and a rest frame K to the observer, so that their x -axes should be parallel to the velocity V of the medium and their y -axes should point downwards.

The Lorentz transformation formulas for velocities (also called Einstein transformation formulas for velocities) can be obtained from formulas (3.12) and (3.15) for the direct transformation, and from formulas (3.13) and (3.16) for the inverse transformation. For a special transformation, V must be parallel to the x - and x' -axes, and for the direct transformation the following formulas can easily be obtained

$$v'_x = \frac{v_x - V}{1 - v_x V/c^2}, \quad v'_y = \frac{v_y (1 - v^2/c^2)^{1/2}}{1 - v_x V/c^2}, \quad (24.4)$$

where v'_x , v'_y are the components of the velocity of a material point with respect to frame K' , and v_x , v_y are its components with respect to frame K .

For our case (fig. 24-1) the components of the velocity of the photons which propagate in vacuum (i.e., before their entrance in the medium) are

$$c_x = c \sin \varphi, \quad c_y = c \cos \varphi, \quad (24.5)$$

$$c'_x = \frac{c \sin \varphi - V}{1 - V \sin \varphi / c}, \quad c'_y = \frac{c \cos \varphi (1 - V^2/c^2)^{1/2}}{1 - V \sin \varphi / c}.$$

Thus the angle of incidence of the photons in frame K' will be

$$\sin \varphi' = \frac{c'_x}{c} = \frac{\sin \varphi - V/c}{1 - V \sin \varphi / c} \cong \sin \varphi - \frac{V}{c} \cos^2 \varphi, \quad (24.6)$$

and the angle of refraction in frame K' , according to Snell's law [see formula (13.31), putting there $n_A = 1, n_B = n$] will be

$$\sin \psi' = \frac{\sin \varphi'}{n} = \frac{1}{n} \left(\sin \varphi - \frac{V}{c} \cos^2 \varphi \right) = \sin \psi + \frac{V}{c} \left(n \sin^2 \psi - \frac{1}{n} \right). \quad (24.7)$$

The components of the velocity of the photons in the medium with respect to frame K' will be

$$c'_{mx} = \frac{c}{n} \sin \psi', \quad c'_{my} = \frac{c}{n} \cos \psi', \quad (24.8)$$

and the components of this velocity with respect to frame K , according to the inverse Lorentz transformation formulas for velocities, will be

$$c_{mx} = \frac{c'_{mx} + V}{1 + c'_{mx} V/c^2}, \quad c_{my} = \frac{c'_{my} (1 - V^2/c^2)^{1/2}}{1 + c'_{mx} V/c^2}. \quad (24.9)$$

Thus, when the medium is moving, the refraction angle with respect to frame K will be

$$\sin (\psi + \delta) = \frac{c_{mx}}{c_m} = \sin \psi + \frac{V}{c} \left(n - \frac{1}{n} \right). \quad (24.10)$$

and for the drag aberration angle we obtain

$$\delta \cong \sin \delta = \frac{V}{c} \left(n - \frac{1}{n} \right) \frac{1}{\cos \psi}. \quad (24.11)$$

This result is unsound, because for $\psi \rightarrow \pi/2$ it gives $\delta \rightarrow \infty$, while obviously, it must be $\delta \rightarrow 0$, as this is to be obtained from our formula (24.3).

It is clear that the automatic application of the Lorentz transformation to the drag aberration leads to an unsound result, and this phenomenon cannot be explained without referring to its physical essence. Thus the Lorentz transformation is not *deus ex machina* and is to be applied with attention, after a due physical analysis of the problem considered. Here we have once more to recognize that physics is not a mathematical apparatus to which a physical reality is attached, but a mathematical apparatus attached to physical reality.

§25. THE HARRESS « ROTATING DISK » EXPERIMENT

The « rotating disk » experiment of Harress-Sagnac-Pogany-Dufour, repeated on the rotating Earth by Michelson-Gale, was the first and, until the performance of our light kinematic experiments, the *unique* experiment which revealed the direction dependence of light velocity and the adequacy of the aether conception to physical reality. Nevertheless, sixty years after its first performance, hundreds of pens have tried to reconcile its decisive positive « aether wind » effect with the uni-directional Einstein's light velocity constancy and thus to convince the scientific community that black is white. The history of this experiment and of its mistreatment by official physics is very instructive, having shown that when the experiments speak the gods keep their silence but the theoreticians do not.

We have considered this experiment in detail in Marinov (1978f) where we have given also the account of two important modifications to it which were performed by us.

Fig. 25-1 presents our set-up for the performance of the « rotating disk » experiment. A medium with refractive index n can rotate (in a clockwise direction) with the semi-transparent mirrors SM , SM_A , SM_B and the mirrors M_1 , M_2 , M_3 , M_{A1} , M_{A2} , M_{A3} , M_{B1} , M_{B2} , M_{B3} , or without them, or only the mirrors can rotate and the medium remain at rest. In the last case, a medium with refractive index $n = 1$, i.e., vacuum (air), can also be taken. So four different combinations are possible which we name :

1. The **Harress-Sagnac experiment**, performed first by Sagnac (1913), in which the mirrors rotate and as a medium a vacuum is taken.

2. The **Harress-Pogany experiment**, performed first by Harress (1912) and repeated very carefully by Pogany (1928), in which the mirrors rotate together with the medium.

3. The **Harress-Marinov experiment**, performed first by Dufour and Prunier (1942) and repeated by Marinov (1978f) in a slightly different ar-

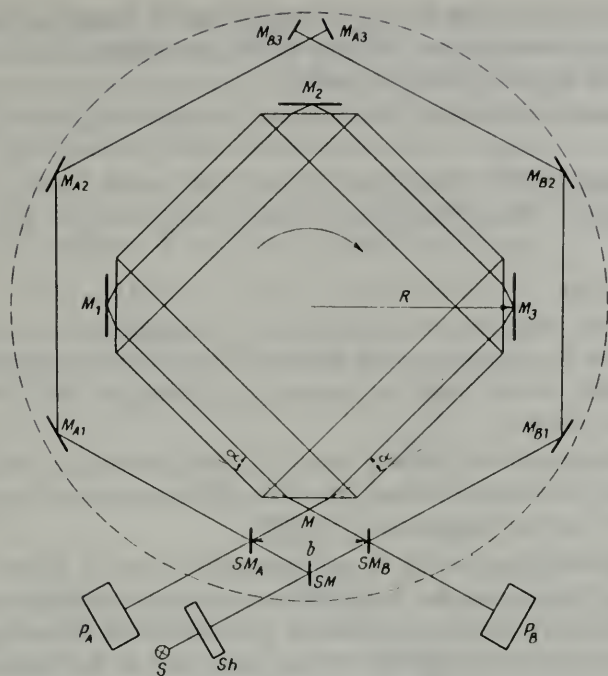

Fig. 25-1

arrangement, in which the mirrors rotate and the medium is at rest. For the sake of unification (see the Zeeman-Marinov experiment in §28.2) we call the common type of the « rotating disk » experiment where the medium is at rest and the mirrors rotate the Harress-Marinov experiment.

4. The **Harress-Fizeau experiment**, performed first by Fizeau (1851) in a substantially different arrangement (called the « water-tube » experiment — see §23), in which the medium rotates and the mirrors are at rest. Our performance of the Harress-Fizeau experiment (Marinov, 1978f) can be considered as the first one.

In fig. 25-1, S is a light source emitting coherent light. Sh is a shutter which is governed by the rotating disk and allows short light pulses to pass only at a strictly defined position of the disk when the diametrically opposite facets of the transparent medium are exactly parallel to the mirrors M_1, M_2, M_3 . The areas of the facets are small and the mirrors are placed near to the medium. Thus we can assume that the photons travel between the single mirrors along the corresponding chords of a circle with radius R . P_A and P_B are two photoresistors put in both arms of a Wheatstone bridge. Always when the shutter Sh allows light to pass, the photoresistors are illuminated *uniformly*

by interfered light. With the aim of explaining the character of the interference, let us consider four photons which are emitted by S at the same moment and cover the following paths :

First photon : $SM - SM_A - M_{A1} - M_{A2} - M_{A3} - M_{A2} - M_{A1} - SM_A - P_A$

Second photon : $SM - SM_B - M_1 - M_2 - M_3 - SM_A - P_A$.

Third photon : $SM - SM_B - M_{B1} - M_{B2} - M_{B3} - M_{B2} - M_{B1} - SM_B - P_B$.

Fourth photon : $SM - SM_A - M_3 - M_2 - M_1 - SM_B - P_B$.

Since the effects in the « rotating disk » experiment are of first order in v/c , they can be considered in the frame of the traditional aether-Newtonian theory which, within such an accuracy, is identical with our absolute space-time theory.

The first and third photons cover the same paths at rest and motion of the mirrors. As a matter of fact, there are differences which are of second order in v/c , and we consider them in §29.

The second photon (which we shall call « direct ») travels along the direction of rotation and the fourth photon (which we shall call « opposite ») travels against the direction of rotation. The differences in the optical paths of the first and second photons, on one hand, and of the third and fourth photons, on the other hand, will change oppositely when changing the rotational velocity. At rest the illuminations over both photoresistors are the same and the bridge is in equilibrium. When increasing the rotation, the bridge comes into greater and greater disequilibrium, passes through a state of maximum disequilibrium and at a certain angular velocity Ω comes again into equilibrium. If the time spent by the second (or fourth) photon for covering its path at the angular velocity Ω differs by Δt_A (Δt_B) from the time spent at rest, and we introduce the notation $\Delta t = \Delta t_A + \Delta t_B$, then $\Delta = c \Delta t$ will be equal to the wavelength λ of the used light.

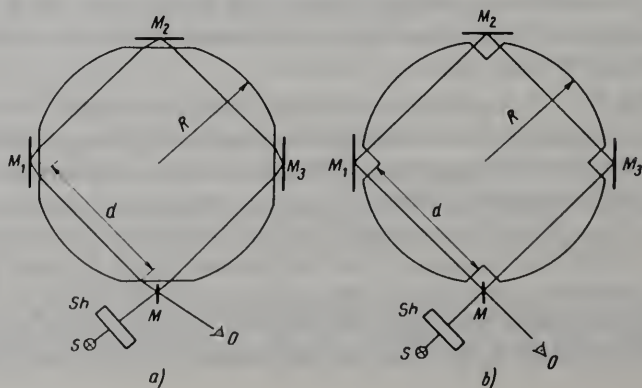

Fig. 25-2

For the calculation of Δt through the parameters of the device, taking into account also the dispersion of the medium, we proceed from the simple scheme of the experiment given in fig. 25-2. Here S is a light source, Sh a shutter governed by the rotating turnabout, M is a semi-transparent mirror where the light pulses separate into « direct » and « opposite », M_1, M_2, M_3 are mirrors and O is an observer who registers the different interference pictures. In fig. 25-1, to the semi-transparent mirror M a point M corresponds which can be considered as an effective point of separation.

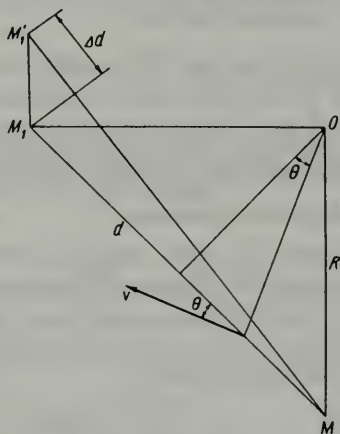

Fig. 25-3

25.1. THE HARRESS-MARINOV EXPERIMENT

First we shall consider the Harress-Marinov and Harress-Dufour experiments, whose schemes are given, respectively, in fig. 25-2a and fig. 25-2b. We suppose that the mirrors rotate in a direct (clockwise) direction and the medium is at rest in absolute space. According to fig. 25-3 (see also fig. 25-2 and fig. 25-1), a « direct » photon which separates from an « opposite » photon at the semi-transparent mirror M will reflect not at point M_1 , where it reflects when the mirrors are at rest, but at a point M'_1 , and thus in the case of rotation its path will be longer by

$$\Delta d = \Omega R \frac{d}{c/n} \cos \frac{\pi}{4} = \frac{\Omega R^2}{c} n, \quad (25.1)$$

where $d = R/\cos(\pi/4)$ is its path when the mirrors are at rest and R is the distance of the mirrors from the centre of rotation. In the case of rotation the path of an « opposite » photon between M and M_3 will be with Δd less than in the case of rest.

Since mirror M (or mirrors SM_A and SM_B in fig. 25-1) moves, then, because of the Doppler effect, the frequencies of the « direct » photons received by the molecules of the medium will be

$$\nu_o = \nu \left(1 + 2 \frac{v}{c} \cos \frac{\pi}{4} \right) = \nu \left(1 + \sqrt{2} \frac{\Omega R}{c} \right), \quad (25.2)$$

while the frequencies of the « opposite » photons received by the molecules of the medium will remain the same.

Hence, if we take into account the dispersion, the refractive index of the medium for the « direct » photons becomes

$$n^* = n(\nu_o) = n + \sqrt{2} \frac{\Omega R}{c} \nu \frac{dn}{d\nu}. \quad (25.3)$$

Thus if the mirrors rotate, a « direct » photon will return to mirror M after an « opposite » photon with the following time delay :

a) for the Harress-Marinov experiment

$$\Delta t_{H-M} = 4 \frac{d + \Delta d}{c/n^*} - 4 \frac{d - \Delta d}{c/n} = 8 \frac{\Omega R^2}{c^2} \left(n^2 - \lambda \frac{dn}{d\lambda} \right), \quad (25.4)$$

b) for the Harress-Dufour experiment

$$\Delta t_{H-D} = 4 \left(\frac{d}{c/n^*} + \frac{\Delta d}{c} \right) - 4 \left(\frac{d}{c/n} - \frac{\Delta d}{c} \right) = 8 \frac{\Omega R^2}{c^2} \left(n - \lambda \frac{dn}{d\lambda} \right). \quad (25.5)$$

Let us note that in our realization of the Harress-Marinov experiment (fig. 25-1), we have to take into account the difference in the light paths which appears along the contour $SM - SM_A - M - SM_B - SM$ when the mirrors rotate. Denoting by b the distances between SM_A and SM_B , we obtain for the area enclosed by this contour

$$S = \frac{b^2}{2} \cot \left(\frac{\pi}{4} + \alpha \right) = b^2 \frac{(2 - n^2)^{1/2}}{2n}, \quad (25.6)$$

where α is the difference between the angles of incidence and refraction, and we have used Snell's law (13.31) which for our case gives

$$\sin \left(\frac{\pi}{4} + \alpha \right) = \frac{\sqrt{2}}{2} n. \quad (25.7)$$

Thus, when the mirrors rotate with an angular velocity Ω , the second photon will come for a rendezvous with the first photon on mirror SM_A with the following additional time anticipation

$$\Delta t_{\text{add}} = \frac{S \Omega}{c^2} = \frac{\Omega b^2}{c^2} \frac{(2 - n^2)^{1/2}}{2n}, \quad (25.8)$$

while the fourth photon will come for a rendezvous with the third photon on mirror SM_B with the same time delay.

25.2. THE HARRESS-FIZEAU EXPERIMENT

The Harress-Fizeau experiment can also be performed in two somewhat different arrangements shown in fig. 25-2a and fig. 25-2b which we shall call, respectively, the Harress-Fizeau-Marinov and Harress-Fizeau-Dufour experiments. We shall consider only the first one, which was carried out by us, calling it the Harress-Fizeau experiment.

We suppose that the medium rotates in direct (clockwise) direction and the mirrors are at rest in absolute space. Now, as can be seen from fig. 25-3, the molecular velocity that makes an angle θ with the direction of propagation of the « direct » photons will have a magnitude

$$v = \frac{\sqrt{2}}{2} \frac{\Omega R}{\cos \theta}. \quad (25.9)$$

Since the medium moves with respect to the mirrors, then, because of the Doppler effect, the frequencies of the « direct » and « opposite » photons received by the molecules will be, respectively,

$$\nu_{\pm} = \nu \left(1 \mp \frac{v}{c} \cos \theta \right) = \nu \left(1 \mp \frac{\sqrt{2}}{2} \frac{\Omega R}{c} \right). \quad (25.10)$$

Hence, if we take into account the dispersion, the refractive indices for the « direct » and « opposite » photons become, respectively,

$$n^{\pm} = n(\nu_{\pm}) = n \mp \frac{\sqrt{2}}{2} \frac{\Omega R}{c} \nu \frac{dn}{d\nu}. \quad (25.11)$$

Thus, if the medium rotates, a « direct » photon will return to mirror M before an « opposite » photon with the time anticipation [use formula (13.16) and compare with formula (23.5)]

$$\Delta t_{H-F} = \frac{4d}{c_m} - \frac{4d}{c_m^*} = 8 \frac{\Omega R^2}{c^2} \left(n^2 - \lambda \frac{dn}{d\lambda} - 1 \right). \quad (25.12)$$

25.2. THE HARRESS-SAGNAC EXPERIMENT

The formula for the effect in the Harress-Sagnac experiment is to be obtained from (25.4) and (25.5), putting there $n = 1$,

$$\Delta t_{H-S} = 8 \frac{\Omega R^2}{c^2} . \quad (25.13)$$

25.4. THE HARRESS-POGANY EXPERIMENT

In the Harress-Pogany experiment the time delay with which a « direct » photon returns to mirror M after an « opposite » photon is equal to the difference in the time delays in the Harress-Marinov and Harress-Fizeau experiments. Thus from formulas (25.4) and (25.12) we obtain

$$\Delta t_{H-P} = \Delta t_{H-M} - \Delta t_{H-F} = 8 \frac{\Omega R^2}{c^2} . \quad (25.14)$$

We must emphasize that in the Harress-Marinov and Harress-Fizeau experiments there is the *same relative motion* between mirrors and medium. However the effects in these two experiments are substantially different because in the Harress-Marinov experiment the medium rests with respect to absolute space, while in the Harress-Fizeau experiment the mirrors rest with respect to absolute space. The theory of relativity meets severe difficulties when trying to explain this difference.

25.5. PRACTICAL PERFORMANCE OF THE HARRESS-MARINOV AND HARRESS-FIZEAU EXPERIMENTS

Our performance of the Harress-Marinov and Harress-Fizeau experiments by the help of the set-up shown in fig. 25-1 is reported in Marinov (1978f).

The difference between our scheme (fig. 25-1) and the traditional scheme of the « rotating disk » experiment (fig. 25-2) is the following : In our realization the « direct » and « opposite » light pulses interfere with light pulses that always cover the same path. Thus the illuminations over the photoresistors P_A and P_B change oppositely, and we can use our convenient bridge method described in §23. A second difference consists in the following : In fig. 25-2, the mirrors M_1, M_2, M_3 are tangent to the circumference of the medium; however semi-transparent mirror M is not tangent and cannot be placed close enough to the medium. In our realization, the separation of

the photons that will later interfere proceeds first at semi-transparent mirror SM and then at semi-transparent mirrors SM_A and SM_B , so that instead of mirror M , there is an effective point of separation M which can lie close enough to the circumference of the medium. Proceeding from formulas (25.4) and (25.8), we obtain the following formula for the calculation of the effect in the Haress-Marinov experiment performed with our set-up

$$\Delta_{H-M} = 8 \frac{\Omega R^2}{c} \left(n^2 - \lambda \frac{dn}{d\lambda} \right) - \frac{\Omega b^2}{c} \frac{(2 - n^2)^{1/2}}{n}. \quad (25.15)$$

It can easily be seen that the formula for the calculation of the effect in the Harress-Fizeau experiment performed with our set-up is to be obtained directly from (25.12) and runs

$$\Delta_{H-F} = 8 \frac{\Omega R^2}{c} \left(n^2 - \lambda \frac{dn}{d\lambda} - 1 \right). \quad (25.16)$$

As a medium we have taken distilled water in a metallic vessel which has a form as shown in fig. 25-1. Glass windows are placed at points where light beams must cross the walls of the vessel. Glass windows also are placed in the metallic interfaces which divide the ring into compartments. Taking into account the thickness of the glass plates and their refractive index, we have put the mirrors M_1, M_2, M_3 at such positions that the actual light path (distance multiplied by refractive index) along the contour $M - M_1 - M_2 - M_3 - M$ is exactly equal to the light path that would be covered if mirrors M_1, M_2, M_3 had been immersed in water.

We have $n = 1,3317$ and $dn/d\lambda = -2,7 \cdot 10^{-5} \text{ nm}^{-1}$, assuming $\delta n = 0$ and $\delta(dn/d\lambda) = 0$, for light of wavelength $\lambda = 632,8 \text{ nm}$ of the He-Ne laser used. Also $R = 30,6 \pm 0,2 \text{ cm}$, $b = 10,0 \text{ cm}$, assuming $\delta b = 0$ and taking a large enough error, $\delta R = \pm 0,2 \text{ cm}$, which also has to compensate for possible errors introduced in the measurement of the thickness of the glass plates and errors that could appear from the replacement of the actual light path by an idealized light path only in water.

We have made the light paths of the first and second photons (as well as of the third and fourth photons) equal. However, since laser light with good coherence is used, this is by no means necessary and the light paths of the first and third photons can be substantially reduced.

The sensitivity of our bridge method is analysed in §23. Let us repeat that a maximum sensitivity is to be obtained when the sum of the differences in the light paths of the first and second photons and in the light paths of the third and fourth photons at rest is $(2n + 1)\lambda/2$, where n is an integer, being $\delta\Delta = \pm 2,5 \cdot 10^{-4} \lambda$. When this sum is equal to $n\lambda$ the sensitivity falls to zero.

We have not searched for the highest sensitivity by the help of a « tuner », as described in §23, and we have taken an average sensitivity $\delta\Delta = \pm 10^{-2}\lambda$. The « tuner » described in §23 can be used also for calibration during the run, however in our method where we change the rotational velocity until $\Delta = c \Delta t$ becomes equal to λ no calibration need be made.

The number of revolutions per second of the disk, $N = \Omega/2\pi$, is measured by a light stroboscopic cyclometer maintained automatically with precision $\delta N = \pm 0,02$ rev/s. We rotated the disk first counter-clockwise with angular velocity Ω_1 , and then clockwise with angular velocity Ω_2 , taking $\Omega = (1/2)(\Omega_1 + \Omega_2)$.

When the disk is at rest the Wheatstone bridge can be set into equilibrium by a micrometrical move of mirror M_{A3} or M_{B3} . If we do not care to do this and if at the beginning the bridge is disequilibrated with a certain « positive » current, then at the angular velocity Ω (counter-clockwise or clockwise) the bridge will be disequilibrated with the same « negative » current. However, in such a case at rest the shutter has to operate with the same chopping frequency with which it operates at the rotational velocity Ω . In the case where the apparatus is thermostabilized, a maximum sensitivity can be achieved by a micrometrical move of both mirrors M_{A3} and M_{B3} .

We obtained $N = 22,68 \pm 0,04$ rev/s for the Harress-Marinov experiment and $N = 50,60 \pm 0,04$ rev/s for the Harress-Fizeau experiment. Substituting the numerical values into formulas (25.15) and (25.16), we obtain, supposing that the velocity of light is an unknown quantity,

$$\begin{aligned} c_{H-M} &= (3,01 \pm 0,07) \cdot 10^8 \text{ m/s}, \\ c_{H-F} &= (2,97 \pm 0,07) \cdot 10^8 \text{ m/s}, \end{aligned} \quad (25.17)$$

where for δc we have taken the maximum measuring error.

§ 26. THE DISRUPTED « ROTATING DISK » EXPERIMENT

The proper time delay in the Harress-Sagnac experiment (see §25.3) can be written in the form

$$\Delta t_0 = \int_0^d \frac{dr}{c'_{\text{dir}}} - \int_0^d \frac{dr}{c'_{\text{opp}}} = \frac{2}{c^2} \int_0^d v \cos \theta' dr, \quad (26.1)$$

where we have used formula (3.32) and with d we designate the whole path.

If working within an accuracy of first order in v/c , a difference between proper and absolute time intervals cannot be made [i.e., we have to assume $\Delta t_0 = \Delta t(1 - v^2/c^2)^{1/2} \cong \Delta t$], and formula (26.1) can be written in the form

$$\Delta t = \frac{2}{c^2} \int_0^d \mathbf{v} \cdot d\mathbf{r}, \quad (26.2)$$

where $d\mathbf{r}$ is the element of the light path of the « direct » photons and \mathbf{v} is the velocity of the corresponding point on the rotating disk with respect to absolute space.

In the « rotating disk » experiments (§25) the point of separation of the « direct » and « opposite » photons is the same, so that the light path of the « direct », as well as of the « opposite », photons must be a closed curve. If we should disrupt these closed paths and make the points of separation and meeting different, the light paths of the « direct » and « opposite » photons which are different at rest and motion of the disk can be made straight lines. We call such an experiment the disrupted « rotating disk » experiment. Its performance is reported in Marinov (1978n) and it patently shows that the velocity of light is direction dependent even along a straight line on a rotating disk.

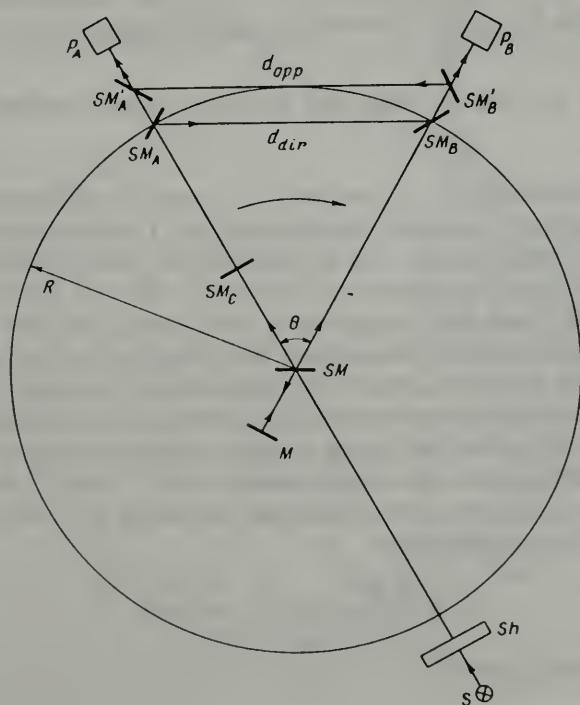

Fig. 26-1

The scheme of the disrupted « rotating disk » experiment is as follows (fig. 26-1): The light source S is a He-Ne laser. Sh is a shutter which is governed by the rotating disk and lets light pass only at a strictly defined position of the disk when both photoresistors P_A, P_B are illuminated. In the case where S, P_A and P_B would also be mounted on the rotating disk, the shutter Sh is unnecessary. SM is a semi-transparent mirror, M a mirror, and SM_C a corrective semi-transparent mirror which reduces the number of photons along the path to SM_A to equal the number of photons along the path to SM_B .

Let four photons be emitted by S at the same moment and suppose that they cover the following paths:

First photon: $S - SM - SM_C - SM_A - SM'_A - P_A$.

Second photon: $S - SM - SM_C - SM_A - SM_B - SM'_B - P_B$.

Third photon: $S - SM - M - SM - SM_B - SM'_B - SM'_A - P_A$.

Fourth photon: $S - SM - M - SM - SM_B - SM'_B - P_B$.

Using formula (26.2) and fig. 26-1, we find that in the case of rotation (with respect to the case at rest) the time in which the third (fourth) photon will reach $P_A (P_B)$ will be with

$$\Delta t_A = \frac{2 \Omega R^2}{c^2} \tan \frac{\theta}{2}, \quad (\Delta t_B = \frac{\Omega R^2}{c^2} \sin \theta), \quad (26.3)$$

shorter than the time in which the first (the second) photon will reach $P_A (P_B)$.

The photoresistors P_A, P_B are put in the arms of a Wheatstone bridge. They are illuminated *uniformly* by interfered light. Let us suppose that when the disk is at rest the bridge is in equilibrium, i.e., both photoresistors are illuminated by equal light intensities. If this is not the case, we move micro-metrically SM'_A and SM'_B , changing in such a way the path difference between the first and third photons until the bridge comes into equilibrium. Then we set the disk in rotation. With the increase of rotational velocity, the bridge comes into greater and greater disequilibrium, passes through a state of maximum disequilibrium, and at a certain angular velocity Ω , when the sum of the differences in the optical paths $\Delta = (\Delta t_A + \Delta t_B) c$ will become equal to the wavelength λ of the used light, the bridge will come again into equilibrium. Thus we shall have

$$\Delta = \frac{\Omega R^2}{c} \left(2 \tan \frac{\theta}{2} + \sin \theta \right), \quad (26.4)$$

where we have to put $\Delta = \lambda$.

We experimentally checked this formula (Marinov, 1978a), taking $\delta\Delta = \pm 10^{-3}\lambda$ (concerning the sensitivity of our bridge method see §23 and §25), $\lambda = 632,8 \text{ nm}$, $\theta = 60^{\circ},0 \pm 0^{\circ},5$, $R = 40,0 \pm 0,2 \text{ cm}$. The number of revolutions per second $N = \Omega/2\pi$ is measured by a light stroboscopic cyclometer and maintained automatically with a precision $\delta N/N = \pm 2 \cdot 10^{-4}$. We registered $N = 92,90 \pm 0,02 \text{ rev/s}$. Putting the figures into formula (26.4), we obtain, supposing that the velocity of light is an unknown quantity,

$$c = (2,98 \pm 0,07) \cdot 10^8 \text{ m/s}, \quad (26.5)$$

where for δc we take the maximum absolute measuring error.

§ 27. THE « COUPLED-SHUTTERS ON A ROTATING DISK » EXPERIMENT

The « coupled-shutters on a rotating disk » experiment, proposed in Marinov (1975b), represents a variant of the disrupted « rotating disk » experiment for the case where the rotation of the disk cannot be changed at will, as it is on our Earth.

Its scheme is as follows (fig. 27-1) : Along the rim of a disk the mirrors M_1, \dots, M_k are placed close enough to each other.

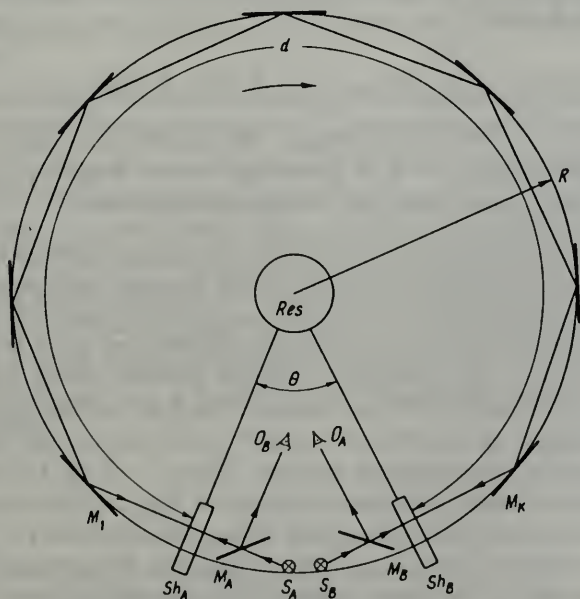

Fig. 27-1

S_A (or S_B) passes through the semi-transparent mirror M_A (M_B) and through the high frequency operating shutter Sh_A (Sh_B). The chopped light reflects on the mirrors M_1, \dots, M_k , passes through the shutter Sh_B (Sh_A) and, being reflected by the semi-transparent mirror M_B (M_A), is observed by the observer O_A (O_B). The shutters operate with the same chopping frequency f , being driven by the common resonator Res put at the centre of the disk. Thus the shutters operate synchronously at rest and when the disk is in motion. As a matter of fact, since the distances between the common resonator and the shutters which the electromagnetic signals have to cover are equal (with respect to the disk but also with respect to absolute space !), the shutters will always be opened and closed together.

Let us suppose first that the disk is at rest and let us denote by d the light path between both shutters. At the condition that $n = (d/c)f$ is an integer (or an integer plus $1/2$), both observers will register maximum (minimum) photon flux. If now we set the disk in rotation in a clockwise direction, then the observer O_A will register maximum photonian flux at the condition that $n_A = (d/c) f (1 + v/c)$ is an integer, while the observer O_B will register maximum photonian flux at the condition that $n_B = (d/c) f (1 - v/c)$ is an integer.

If d and v are given and f changes, then both observers consequently should register « equal » or « opposite » pictures, e.g., « O_A and O_B together see maximum light », or « O_A sees maximum light when O_B sees minimum light ». Indeed, we have

$$n_A = n_B \frac{c + v}{c - v} \cong n_B + 2 \frac{v}{c} n = n_B + \Delta n. \quad (27.1)$$

Thus if $\Delta n = 2 d v f / c^2$ is an integer, the observers O_A and O_B should register « equal » pictures and if Δn is equal to an integer plus $1/2$, the observers O_A and O_B should register « opposite » pictures.

If the angle θ is almost equal to 2π and the radius of the disk R is very large, then we can consider the motion of the coupled shutters as inertial. This can be practically realized if one takes as a rotating disk our Earth and puts the common resonator at the pole. As shutters two Kerr cells can be used, separated by a short distance d (about 100 km) along the equator (placed, say, on the peaks of two mountains). As light sources lasers can be used. The commanding signals can be sent from the pole to the shutters by the help of several retranslation stations. For $v = 0.45$ km/s (that is approximately the linear rotational velocity of the Earth's equator) and $d = 100$ km, one should have $\Delta n \cong 0$ for f low, $\Delta n = 1/2$ for $f = 5 \cdot 10^8$ Hz, $\Delta n = 1$ for $f = 10^9$ Hz, and so on. Thus, changing the commanding frequency in this range, one should change the pictures registered by both

observers from « equal » to « opposite », again to « equal », and so on, and the linear rotational velocity of the Earth's equator can be measured using the direction dependence of light velocity along a straight line.

It can easily be seen that if the resonator is put on a parallel with latitude φ and the coupled shutters along a parallel with latitude φ_0 , it will be

$$\Delta n = 2 \frac{\Omega R}{c^2} df(\cos \varphi_0 - \cos \varphi). \quad (27.2)$$

§ 28. THE ZEEMAN « MOVING PLATFORM » EXPERIMENT

The « moving platform » experiment is considered by us in detail in Marinov (1978m) where we give also an account of three important modifications performed by us.

The « moving platform » experiment is an analogue of the « rotating disk » experiment, where the motion of the medium or/and the mirrors (the interferometer) is not rotational but inertial. Now, again, four combinations can be realized which we call :

1. The **Zeeman-Fizeau experiment**, in which the mirrors are at rest and the medium moves. This experiment was performed first by Fizeau (1851) with water and by Michelson and Morley (1886) with a solid medium. It was very carefully repeated by Zeeman (1914, 1915, 1920, 1922) with liquid and solid media.

2. The **Zeeman-Marinov experiment**, in which the medium is at rest and the mirrors move. This experiment was performed first by Marinov (1978m).

3. The **Zeeman-Pogany experiment**, in which mirrors and medium move together. This experiment was performed by Marinov (1978m) and, as a matter of fact, it can be carried out by anyone who would take the care to observe whether the interference picture in a Zeeman-type implement, in which *mirrors and medium are at rest*, should change during a day when the absolute velocity of the implement changes as a result of the Earth's rotation.

4. The **Zeeman-Sagnac experiment**, in which the mirrors move and a vacuum (air) is taken as a medium. This experiment was performed by Marinov (1978m).

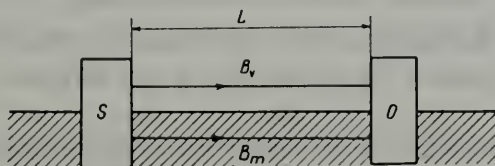

Fig. 28-1

Let us reduce the « moving platform » experiment, stripped of all fundamentally irrelevant details, to the following ideal arrangement (fig. 28-1) : The box S contains a monochromatic source together with a device producing two parallel coherent beams — B_v , which propagates in vacuum and B_m which propagates in a medium with refractive index n . After travelling a distance L , they enter a second box O in which they are united and their interference observed. Both boxes are halfway immersed in the medium. First the boxes (also called mirrors) and the medium are at rest and a specific interference picture is observed. Then one realizes the four different combinations mentioned above, and from the difference in the observed interference pictures conclusions can be drawn about the character of light propagation. We suppose that the motion of the medium, or of the boxes, or both, proceeds from left to right.

28.1. THE ZEEMAN-FIZEAU EXPERIMENT

In §23 we have obtained the formula for the Zeeman-Fizeau (i.e., for the « water-tube ») experiment [see formula (23.5)]. For methodological reasons we shall again deduce this formula.

The velocity of light in a medium moving with velocity v , if measured by an observer at rest, is [see formulas (13.16) and (23.4)]

$$c_m = \frac{c}{n} + v \left(1 + \frac{v}{n^2} \frac{dn}{dv} - \frac{1}{n^2} \right) \cos \theta, \quad (28.1)$$

where ν is the frequency of the light used and θ is the angle between v and the direction of light propagation.

When mirrors and medium in fig. 28-1 are at rest, a photon proceeding along the path B_m (a B_m -photon) will arrive at box O with the following time delay after a photon proceeding along the path B_v (a B_v -photon).

$$t = \frac{L}{c/n} - \frac{L}{c} = \frac{L}{c} (n - 1). \quad (28.2)$$

When the medium is set in motion the time delay will become (for fig. 28-1 it is $\theta = 0$)

$$t_{Z-F} = \frac{L}{c_m} - \frac{L}{c} = \frac{L}{c} \left[n - 1 - \frac{v}{c} (n^2 - \nu \frac{dn}{d\nu} - 1) \cos \theta \right]. \quad (28.3)$$

Hence, for the Zeeman-Fizeau experiment, the effect to be observed in the interference picture will correspond to a time difference

$$\Delta t_{Z-F} = t - t_{Z-F} = \frac{L v}{c^2} (n^2 + \nu \frac{dn}{d\nu} - 1) \cos \theta. \quad (28.4)$$

28.2 THE ZEEMAN-MARINOV EXPERIMENT

The velocity of light measured by an observer who moves with velocity v with respect to a medium that rests in absolute space is [use formula (13.26) and take into account formula (25.3)]

$$c'_m = \frac{c}{n} - v \left(\frac{v}{n^2} \frac{dn}{dv} + 1 \right) \cos \theta, \quad (28.5)$$

where ν is the frequency of the light used and θ is the angle between v and the direction of light propagation.

For $n = 1$, i.e., for vacuum, we obtain

$$c' = c - v \cos \theta. \quad (28.6)$$

When the mirrors are set in motion the time delay with which a B_m -photon arrives at box O after a B_s -photon becomes (for fig. 28-1 it is $\theta = 0$)

$$t_{z-m} = \frac{L}{c'_m} - \frac{L}{c'} = \frac{L}{c} \left[n - 1 + \frac{v}{c} \left(n^2 + v \frac{dn}{dv} - 1 \right) \cos \theta \right]. \quad (28.7)$$

Hence, for the Zeeman-Marinov experiment, the effect to be observed in the interference picture will correspond to a time difference

$$\Delta t_{z-m} = t - t_{z-m} = - \frac{L v}{c^2} \left(n^2 + v \frac{dn}{dv} - 1 \right) \cos \theta. \quad (28.8)$$

The effects in the Zeeman-Fizeau and Zeeman-Marinov experiment are exactly the same, however *these two experiments physically are not equivalent*, and the formulas with which we obtain identical results are *different*. According to the principle of relativity, no physical difference can be made between the Zeeman-Fizeau and Zeeman-Marinov experiments, and special relativity considers the latter only as trivial tautology of the former.

With the aim of showing that these two experiments are physically different, we have performed them in the non-inertial variant considered in §28.5, where the identical effects can be explained only if the formulas used for their calculation are different, as we do in absolute space-time theory.

28.3. THE ZEEMAN-POGANY EXPERIMENT

The velocity of light in a medium moving with velocity v , if measured by an observer who moves with the same velocity, is [see formula (13.28)]

$$c'_m = \frac{c}{n} - \frac{v}{n^2} \cos \theta, \quad (28.9)$$

where θ is the angle between v and the direction of light propagation.

When the mirrors are set in motion with the medium, the time delay with which a B_m -photon arrives at box O after a B_v -photon will be (for fig. 28-1 it is $\theta = 0$)

$$t_{Z-P} = \frac{L}{c'_m} - \frac{L}{c'} = \frac{L}{c} (n - 1). \quad (28.10)$$

Hence, for the Zeeman-Pogany experiment, the effect to be observed in the interference picture will correspond to a time difference

$$\Delta t_{Z-P} = t - t_{Z-P} = 0, \quad (28.11)$$

and thus no change can be registered.

28.4. THE ZEEMAN-SAGNAC EXPERIMENT

The effect for the Zeeman-Sagnac experiment can be obtained immediately from formula (28.8), putting $n = 1$, or from formula (28.11), i.e.,

$$\Delta t_{Z-S} = 0 \quad (28.12)$$

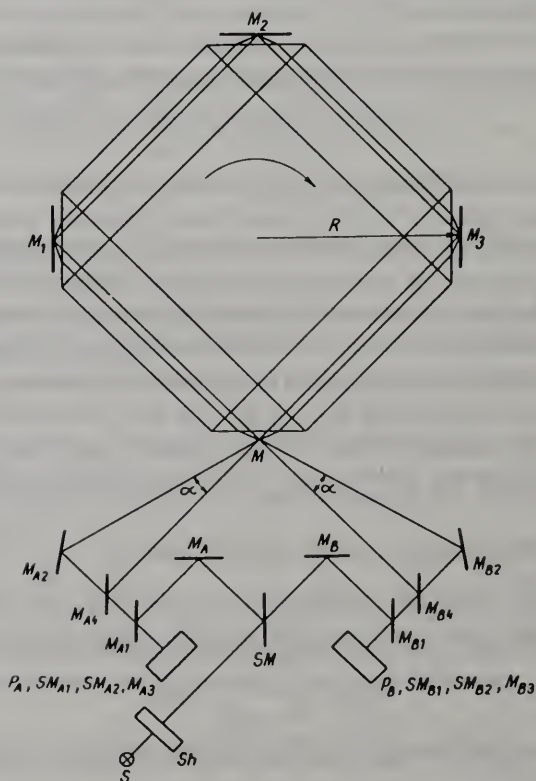

Fig. 28-2

28.5. THE NON-INERTIAL « MOVING PLATFORM » EXPERIMENT

The scheme of our set-up for the performance of the Zeeman experiments is shown in fig. 28-2. We call this variant of the Zeeman experiment the **non-inertial** « moving platform » experiment, while the variant shown in fig. 28-1 can be called the **inertial** « moving platform » experiment.

S is a light source, Sh a shutter which is governed by the rotating turnabout and lets light pulses (of a duration $\cong 10^{-6}$ s) pass only when the mirrors M_1, M_2, M_3 are parallel to the diametrically opposite small sides of the medium. As a transparent medium we have taken distilled water put in a metallic vessel of the form shown in fig. 28-2, which was the same as that used in the « rotating disk » experiment (§25). Glass windows are placed at points where the light beams must cross the walls. Glass windows are placed also in the metallic interfaces which divide the ring into compartments. Taking into account the thickness of the glass plates and their refractive index, we have put the mirrors M_1, M_2, M_3 in such positions that the real light path (distance multiplied by refractive index) along the contour $M-M_1-M_2-M_3-M$ should be exactly equal to the light path which is to be covered if mirrors M_1, M_2, M_3 were *immersed* in water. The distance between mirrors M_1 and M_3 , and also between mirror M_2 and point M , is $2R$.

The light beam emitted by S splits at semi-transparent mirror SM into A -beam and B -beam which follow identical paths and for this reason we shall follow only the A -beam. After reflection on mirrors M_A and M_{A1} , the A -beam reflects on semi-transparent mirror SM_{A1} and goes *upwards*. Then it splits into two daughter beams at semi-transparent mirror SM_{A2} which is placed above SM_{A1} and their planes make a right angle. The A' -daughter-beam reflected on SM_{A2} then reflects on mirror M_{A2} , enters into the medium, reflects successively on mirrors M_3, M_2, M_1 , and, leaving the medium, reflects on mirror M_{B2} . Then it reflects on semi-transparent mirror SM_{B2} and, going *downwards* through the semi-transparent mirror SM_{B1} , illuminates the photoresistor P_B . The A'' -daughter-beam refracted on SM_{A2} goes further *upwards*, reflects on mirror M_{A4} , and, proceeding *above* the medium, reflects successively on mirrors M_3, M_2, M_1 and M_{B4} . Then it reflects on mirror M_{B3} and, going *downwards* through the semi-transparent mirror SM_{B2} (where it interferes with the A' -daughter-beam) and through semi-transparent mirror SM_{B1} , illuminates the photoresistor P_B .

The angle α between the projections of the A' - and A'' -daughter-beams in the plane of the figure, before the entrance of the A' -beam into the medium and after its exit, can be determined from Snell's law (25.7).

The photoresistors P_A and P_B which are illuminated *uniformly* by the interfering B - and A -daughter-beams are put in the arms of a Wheatstone bridge, which is described in more detail in §23 and §25. We have not searched for the highest sensitivity by the help of a « tuner », as described in §23, and we have assumed an average sensitivity $\delta\Delta = \pm 10^{-2}\lambda$.

We take (Landolt-Börnstein, 1962) $n = 1,3317 \pm 0,0003$ for the light with $\lambda = 632,8$ nm of the He-Ne laser used. The error δn corresponds to a change in the refractive index with the temperature which was maintained at $T = 20^\circ \pm 3^\circ$ C, since it is $dn/dT = 10^{-4}$ degree $^{-1}$. From the same source we have taken $dn/d\lambda = -2,7 \cdot 10^{-5}$ nm $^{-1}$, assuming $\delta(dn/d\lambda) = 0$. We had $R = 30,6 \pm 0,2$ cm. We measured $N_{Z-F} = 50,80 \pm 0,04$ rev/s for the Zeeman-Fizeau experiment and $N_{Z-M} = 50,94 \pm 0,04$ rev/s for the Zeeman-Marinov experiment, having $N = \Omega/2\pi$. Putting these figures into formulas (28.4) and (28.8) and taking into account that it is

$$L = 4\sqrt{2}R, \quad v = \frac{\sqrt{2}}{2} \frac{\Omega R}{\cos\theta}, \quad (28.13)$$

we obtain, supposing that the velocity of light is an unknown quantity,

$$\begin{aligned} c_{Z-F} &= (3,01 \pm 0,07) \cdot 10^8 \text{ m/s}, \\ c_{Z-M} &= (3,02 \pm 0,07) \cdot 10^8 \text{ m/s}, \end{aligned} \quad (28.14)$$

where for δc we have taken the maximum absolute measuring error.

In the Zeeman-Pogany and Zeeman-Sagnac experiments we registered no perceptible disequilibrium of the bridge when rotating the disk.

Let us mention that the measuring procedure in the « rotating disk » experiment (§25) is very similar to that in the non-inertial « moving platform » experiment. We performed the « moving platform » experiment in its non-inertial variant, aiming to use the set-up constructed for our « rotating disk » experiment. On the other hand, we think that the results of the non-inertial variant are *more important* than the same results which could be obtained with the inertial variant. Indeed, since we already know that the velocity of light with respect to a rotating disk is direction dependent, then the identical effects in the Zeeman-Fizeau and Zeeman-Marinov experiments can be explained only by our theory which obtains these effects by proceeding from *substantially different formulas*.

§ 29. THE SECOND-ORDER EFFECTS IN THE « ROTATING DISK » EXPERIMENT

The measurement of the second-order effects in the Harress-Marinov, Harress-Fizeau and Zeeman-Marinov, Zeeman-Fizeau experiments is a dif-

difficult problem because there is a relative motion between mirrors and medium. In the Zeeman-Pogony and Zeeman-Sagnac experiments the second-order effects are null, and thus only the Harress-Sagnac and Harress-Pogony experiments are convenient for the measurement of second-order in v/c effects. Nevertheless, since these effects are very faint, such an experiment is very delicate, and in our laboratory there are no possibilities for its performance. For this reason we shall consider the experiment for the measurement of the second-order effects in the « rotating disk » experiment, without entering into the details of an eventual practical performance, as in Marinov (1976b). When calculating the effects, we shall not take into account the dispersion of the medium, i.e., we shall suppose $dn/d\lambda = 0$.

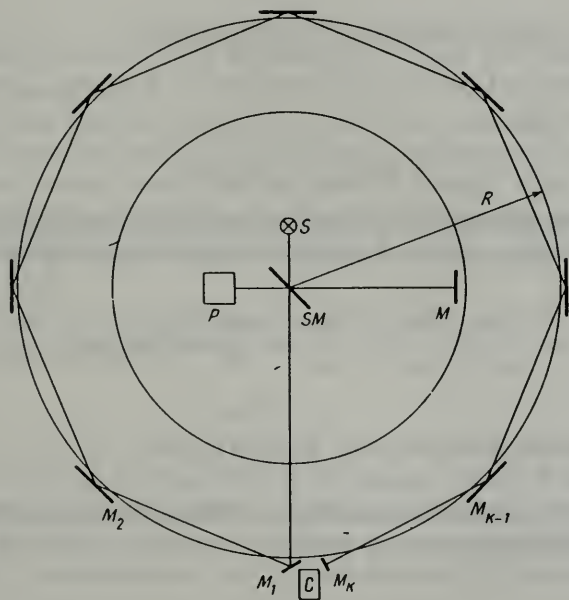

Fig. 29-1

The scheme for the measurement of the second order effects in the « rotating disk » experiment is shown in fig. 29-1. S is a light source which is rigidly connected with the mirrors, because the effect to be measured is too small and the use of a shutter which is governed by the rotating disk would, probably, discredit the experiment. P is a photoresistor illuminated by interfered light. It is put in one arm of a Wheatstone bridge and in the other arm there is a variable resistor. We assume that the mirrors $M_1, M_2, \dots, M_{K-1}, M_K$ are placed near to the rim of the medium's disk and close to each other. Thus we can assume that the photons fly along the circumference of a circle and cover a path $d = 2\pi R$.

Suppose first that the disk is at rest. Light emitted by the source S is split by the semi-transparent mirror SM into reflected and refracted beams. The reflected beam reflects on mirror M and, after refraction on SM , illuminates P . The refracted beam reflects successively on M_1, \dots, M_k clockwise, on M_k, \dots, M_1 counter-clockwise and, after reflection on SM , illuminates P .

If we now set the disk in rotation, then the reflected beam will not change the time in which it covers its path because it moves only along the radius of the rotating disk, while the refracted beam (which has the same « radial motion » if the distances from SM to M and M_1 are equal) changes its time with Δt . Now we shall calculate this time difference for the four different types of the « rotating disk » experiment.

29.1. THE HARRESS-MARINOV EXPERIMENT

Using formula (13.23) at the condition $\theta_0 = 0$ and taking into account that it is [see (4.2)]

$$c'_m = c'_{om} (1 - v^2/c^2)^{1/2}, \quad (29.1)$$

we find that the difference in the absolute times which the refracted beam has to spend covering its path in the cases of rest and rotation of the mirrors will be

$$\Delta t_{H-M} = \frac{d}{c'_m} + \frac{d}{c'_m} - \frac{2d}{c_m} = \frac{d v^2}{c^3} n (2n^2 - 1). \quad (29.2)$$

29.2. THE HARRESS-SAGNAC EXPERIMENT

For $n = 1$, i.e., for the second-order effect in the Harress-Sagnac experiment, we obtain from formula (29.2)

$$\Delta t_{H-S} = \frac{d v^2}{c^3}. \quad (29.3)$$

29.3. THE HARRESS-FIZEAU EXPERIMENT

Using formula (13.12) at the condition $\theta_0 = 0$, we find that the difference in the absolute times which the refracted beam has to spend covering its path in the cases of rest and rotation of the medium will be

$$\Delta t_{H-F} = \frac{d}{c'_m} + \frac{d}{c'_m} - \frac{2d}{c_m} = \frac{2d v^2}{c^3} n (n^2 - 1). \quad (29.4)$$

29.4. THE HARRESS-POGANY EXPERIMENT

Using formula (13.28) at the condition $\theta' = \theta = 0$ and formula (29.1), we find that the difference in the absolute times which the refracted beam has to spend covering its path in the cases of rest and rotation of mirrors and medium will be

$$\Delta t_{H-P} = \frac{d}{c_m'^+} + \frac{d}{c_m'^-} - \frac{2d}{c_m} = \frac{d v^2}{c^3} n. \quad (29.5)$$

This formula for $n = 1$ gives again the second-order effect (29.3) in the Harress-Sagnac experiment.

29.5. CONNECTION WITH KINEMATIC TIME DILATION

As we have said (§2.1 and §2.4), a light clock represents a light source and a mirror placed in front of it, between which a light pulse goes to and fro. Instead of one mirror we can have an arbitrary number. It is of importance only that a light pulse which leaves a given point returns to it and repeats this cycle uninterruptedly. Thus our mirrors $M_1, M_2, \dots, M_k, \dots, M_2, M_1$ also represent a light clock.

Let the time which a light pulse spends covering path d to and fro be T when the mirrors are at rest. Thus

$$T = \frac{2d}{c} \quad (29.6)$$

is the rest period of our clock. When the mirrors are set in motion with a rotational velocity $v = \Omega R$, where Ω is the angular velocity, the period of the light clock in motion measured in absolute time, i.e., by the help of a clock which rests in absolute space, will be [use formula (3.31) at the condition $\theta = \theta' = 0$]

$$T_o = \frac{d}{c'^+} + \frac{d}{c'^-} = \frac{2d}{c(1 - v^2/c^2)^{1/2}} = \frac{T}{(1 - v^2/c^2)^{1/2}}, \quad (29.7)$$

while the same period measured in proper time, i.e., by the help of a clock which is attached to the rim of the moving disk, will be [use formula (3.32) at the condition $\theta = \theta' = 0$]

$$T_{oo} = \frac{d}{c_o'^+} + \frac{d}{c_o'^-} = \frac{2d}{c} = T. \quad (29.8)$$

Thus, the period of our light clock rotating with velocity v in absolute space, as well as the period of any light clock proceeding as a whole with

velocity v , becomes longer according to formula (29.7). We have called this effect the absolute kinematic time dilation (§11.1).

According to our tenth axiom, the time unit for any observer is determined by the period of a light clock which has the same « arm » for all observers. When the « arm » is $d = 150,000$ km, this time unit is called a second. If the observer is at rest in absolute space, his second is called absolute. If the observer moves with a certain velocity in absolute space, his second is called proper. Any proper second is larger than the absolute second and the relation is given by formula (29.7), where the durations of T and T_0 are given in the same time. Thus the change in the duration of the period of a light clock when in motion can be established by comparing its period with a periodical process of a system which is at rest in absolute space (in general, one that does not change its velocity when the light clock under investigation changes its velocity). If we should compare the period of the light clock considered with the periodical process of a system which constantly moves with the same velocity as the light clock, then no change can be registered, as follows from formula (29.8), where the period of the moving light clock is given in proper time and the period of the same clock at rest in absolute time. This is due to the absolute time dilation, by which the rhythm of any periodical process decreases, according to formula (29.7), if the corresponding system is set in motion with velocity v .

All these assertions of our absolute space-time theory can be verified experimentally if one measures the second-order effects in the Harress-Sagnac experiment.

The second-order effects in the Harress-Sagnac experiment have been treated by Burcev (1974) who proposed also an experiment for their measurement. Burcev's proposal consists of the following: Let us have a number ($\cong 3$) of artificial satellites moving along the same circular trajectory round the Earth with a certain velocity v . If a radar pulse is emitted from one of the satellites, then, by means of reflections in the other satellites, this radar pulse can be again received after having covered a closed path round the Earth and the time of delay can be measured with a high precision. If we suppose that the satellites are placed close enough to each other, then the trajectory of the radar wave can be assumed as circular and the gravitational potentials at all points crossed by the wave as equal. We can treat Burcev's proposal by the help of our figure 29-1, assuming that clock C (an atomic clock) is attached to the mirrors M_1 and M_k , so that the time in which a light pulse covers the path from M_1 to M_k and from M_k to M_1 , can be measured.

According to Einstein's theory of general relativity (see, for example, Landau and Lifshitz, 1959), this time, for the « direct » (+) and « opposite » (-) pulses, respectively, is

$$t_E^\pm = t \frac{1 \pm v/c}{(1 - v^2/c^2)^{1/2}}, \quad (29.9)$$

where $t = d/c = 2\pi R/c$ is the time registered on the same clock if the disk is at rest.

According to the traditional Newtonian aether theory this time is

$$t_N^\pm = \frac{t}{1 \mp v/c}. \quad (29.10)$$

According to our absolute space-time theory this time is [use formula (3.32)]

$$t_M^\pm = t_o^\pm = \frac{d}{c_o^\pm} = t(1 \pm v/c). \quad (29.11)$$

If this time is measured on a clock resting in absolute space, it will be [use formula (3.31)]

$$t^\pm = \frac{d}{c'^\pm} = t \frac{1 \pm v/c}{(1 - v^2/c^2)^{1/2}}. \quad (29.12)$$

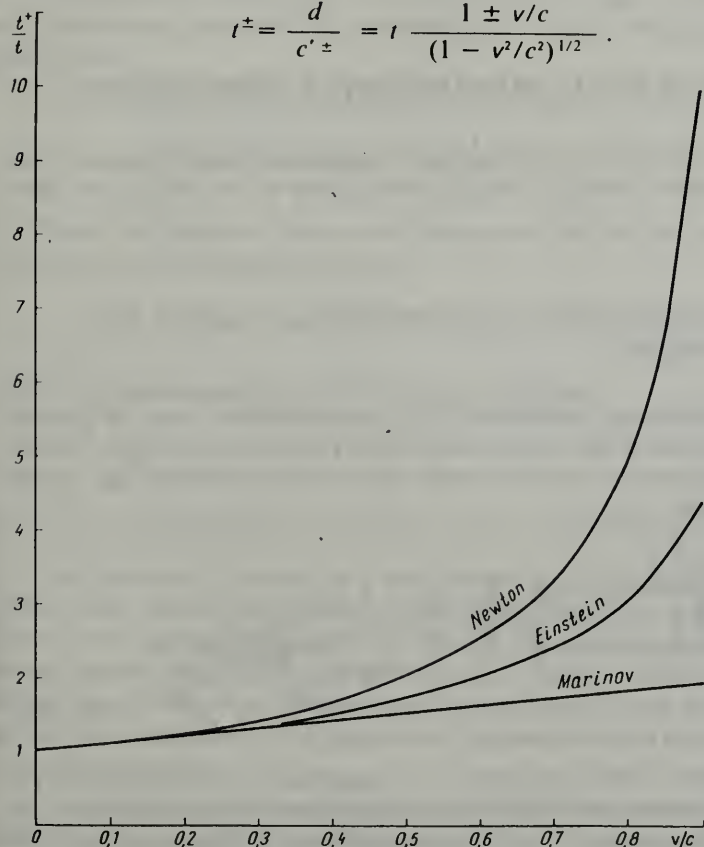

Fig. 29-2

When we try to measure the absolute time intervals t^\pm by the help of a clock which rests in absolute space, the problem arises about the time synchronization of spatially separated clocks. This problem is solved by us (theoretically and experimentally) with the help of a rotating rigid shaft. However, in the « rotating disk » experiment the problem about the time synchronization of spatially separated clocks can be eliminated if we choose an appropriate rotational velocity v , so that the light pulse, emitted by M_1 when it passes near to the clock C which is at rest, will arrive at M_k when M_k passes (after one or more revolutions) near to C .

In fig. 29-2 we give the graphs of the relation t^\pm/t versus v/c drawn according to formulas (29.9), (29.10) and (29.11). Thus an experiment as that proposed by Burcev can choose between these three rival theories. We think, however, that there is no need to perform this costly experiment, since, in the light of the present book, it is obvious our formula will correspond to physical reality.

§ 30. THE LIGHT DOPPLER-EFFECT EXPERIMENTS

Now we shall discuss certain light Doppler-effect experiments, considered in Marinov (1978e), in which second-order in v/c effects have been observed.

30.1. THE IVES-STILWELL LONGITUDINAL « CANAL RAY » EXPERIMENT

The experimental verification of the second-order terms in formula (10.5) was performed first by Ives and Stilwell (1938) who used light emitted by the moving ions in a canal ray tube, and we have called this the « canal ray » experiment.

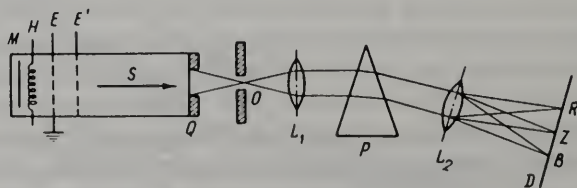

Fig. 30-1

The scheme of their experiment *in a simplified version* is shown in fig. 30-1. Positive ions are produced in a hydrogen arc between the heater H and the perforated electrodes E and E' . Between E and E' the ions are accelerated

by an electric field, thus forming the beam S that represents the moving source. These ions proceed with a constant velocity v which depends on the voltage applied between E and E' . The photons emitted by the excited ions, passing through the large slit Q , illuminate the narrow slit O which represents the observer at rest. To analyse the energies (i.e., the frequencies) of the photons, a spectroscope is used of which we show the focusing lenses L_1, L_2 , the refractive prism P and the screen D .

The mirror M will reflect the light emitted by the ions which move away from it with velocity v . Thus three groups of photons will flow to the screen :

- a) Photons with frequency ν emitted by the ions at rest, before being accelerated by the electrodes; they will illuminate the zero point Z .
- b) Photons with frequency ν^+ shifted to the « blue end » which are emitted by the moving ions; they will illuminate point B .
- c) Photons with frequency ν^- shifted to the « red end » which are emitted by the moving ions and then reflected by the mirror M ; they will illuminate point R .

According to formula (10.5), under the condition $\theta'_0 = \theta = 0$, we obtain

$$\nu^{\pm} = \nu \left(1 \pm \frac{v}{c} + \frac{1}{2} \frac{v^2}{c^2} \right). \quad (30.1)$$

Thus the middle of these two frequencies will be shifted from the frequency ν over a frequency interval

$$\Delta\nu = \frac{\nu^+ + \nu^-}{2} - \nu = \frac{1}{2} \nu \frac{v}{c^2}, \quad (30.2)$$

which was experimentally verified by Ives and Stilwell.

30.2. THE TRANSVERSE « CANAL RAY » EXPERIMENT

The transverse « canal ray » experiment was proposed by Marinov (1970, 1972a, 1978e). Its scheme is shown in fig. 30-2. The system for production and acceleration of the ions is as in fig. 30-1. The photons emitted by the excited ions, passing through the large slit Q , illuminate the narrow slit O behind which there is an indicator that gives indication only when photons are incident with frequency ν equal to the frequency emitted by the ions used when they are at rest.

From fig. 30-2 and from the first formula (10.5) we obtain that on the indicator photons will fall with frequency

$$\nu_o = \frac{(1 - v^2/c^2)^{1/2}}{1 + \frac{v}{c} \cos(\frac{\pi}{2} + \theta \pm \frac{\alpha}{2})} = \nu [1 + \frac{v}{c} (\theta \pm \frac{\alpha}{2}) - \frac{v^2}{2c^2}], \quad (30.3)$$

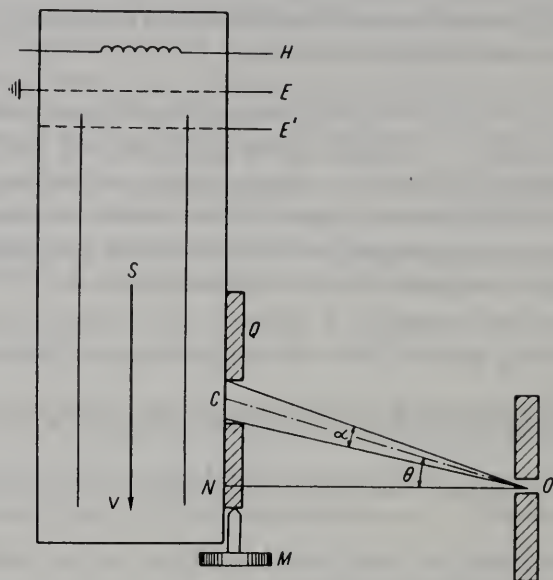

Fig. 30-2

where θ is the angle between the perpendicular ON to the ions' beam and the line OC connecting slit O with the centre of slit Q ; α is the angle under which slit Q is seen from point O . If we choose $\alpha \ll \theta$, then on the indicator photons with frequency ν will fall only at the condition

$$\theta = \nu/2c. \quad (30.4)$$

Hence the experiment is to be performed as follows: For any voltage applied to the electrodes, i.e., for any velocity v of the ions, we search for a position of slit Q at which the indicator will show availability of photons with frequency ν . Then the theory is to be proved by plotting $2\theta c$ versus ν ; the locus must be a straight line dividing the quadrant.

30.3. THE HAY « ROTOR » EXPERIMENT

The scheme of the so-called « rotor » experiment performed first by Hay *et al.* (1960), where the Mössbauer effect is used, is as follows (fig. 30-3):

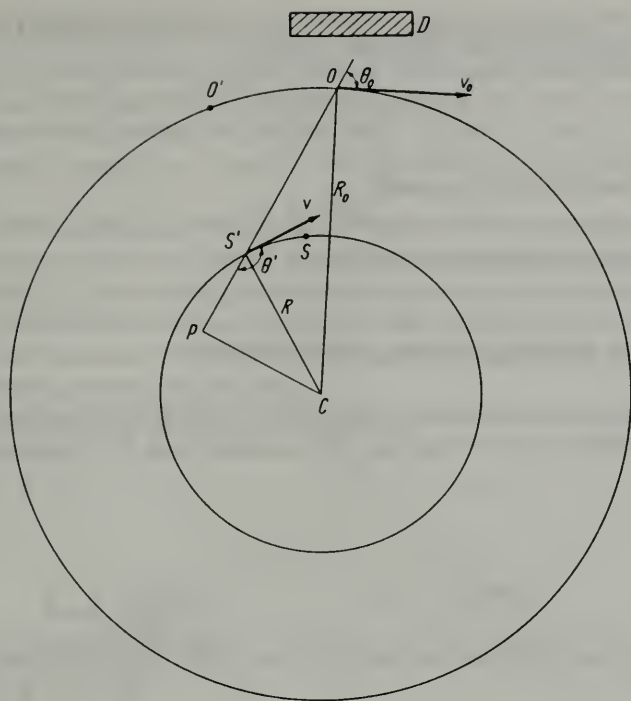

Fig. 30-3

A radioactive ^{57}Co , representing the source, was put on a rotating disk at a distance R from the centre of rotation C . A thin ^{57}Fe absorber, representing the observer, was put around the circumference of the rotating disk at a distance R_0 from the centre of rotation. A detector D at rest was used to measure the rate of the γ -photons emitted by the source passing through the absorber. The transmission of the absorber was measured for various angular velocities. This transmission was found to increase as the angular velocity increased, indicating a shift in the characteristic frequency of the absorber.

Since the line shape of the absorber at rest was known experimentally, the magnitude of the frequency could be estimated, and it was found to agree with the frequency shift calculated according to formula (10.17).

Let us make the calculation. From the triangles OPC and $S'PC$ in fig. 30-3 we obtain the relation

$$R_0 \cos \theta_0 = - R \cos \theta' . \quad (30.5)$$

Now substituting

$$v = \Omega R , \quad v_0 = \Omega R_0 , \quad (30.6)$$

where Ω is the angular velocity of rotation, into the first formula (10.17) and keeping in mind (30.5), we obtain the relation

$$v_o = v \left(\frac{1 - v^2/c^2}{1 - v_o^2/c^2} \right)^{1/2}, \quad (30.7)$$

which was verified experimentally.

We emphasize that formula (30.7) is valid for any position of source and observer on the circumferences with radii R and R_o .

30.4. THE « ROTOR-ROTOR » EXPERIMENT

Now we shall consider the « rotor-rotor » experiment proposed by us in Marinov (1978e) and, to a certain extent, carried out by Champeney *et al.* (1963).

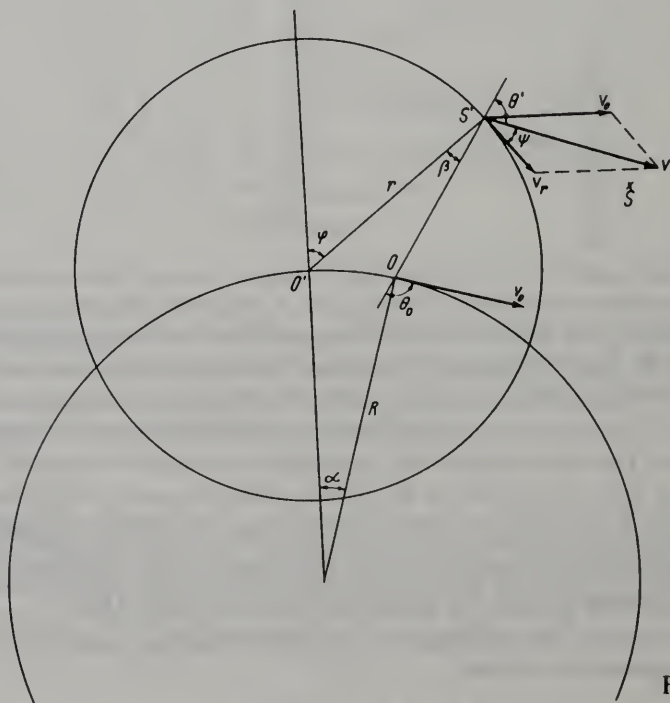

Fig. 30-4

It can be realized (fig. 30-4) when the centre of the rotor considered above (which we shall call the small rotor) rotates at angular velocity Ω and linear velocity v_o , with respect to some centre, thus making another rotor

which we call the big rotor. The radii of the small and big rotors are denoted by r and R . The angular velocity of rotation of the small rotor about its own centre is denoted by ω . We shall suppose that the source is placed at the tip of the small rotor and the observer is at its centre. The linear velocity of rotation of the source is denoted by v_r and its absolute velocity by v . Thus it will be

$$\mathbf{v} = \mathbf{v}_r + \mathbf{v}_o. \quad (30.8)$$

The angle between \mathbf{v}_r and \mathbf{v} is denoted by ψ . The angle between \mathbf{R} and \mathbf{r} is denoted by φ . The small angle between the observer's radii at the emission and reception moments is denoted by α and the small angle under which the emission and reception positions of the observer are seen from the emission position of the source is denoted by β .

We have from fig. 30-4 (see also fig. 10-2)

$$\theta' = \frac{\pi}{2} - \psi + \beta, \quad \theta_o = \frac{\pi}{2} + \varphi - \alpha - \beta, \quad (30.9)$$

where

$$\alpha = \frac{v_o r}{c R}, \quad \beta = \frac{v_o}{c} \cos \varphi. \quad (30.10)$$

Putting (30.10) into (30.9) and taking into account that α and β are small quantities, we can write

$$\cos \theta' = \sin \psi \cos \beta - \cos \psi \sin \beta = \sin \psi - \frac{v_o}{c} \cos \varphi \cos \psi, \quad (30.11)$$

$$\begin{aligned} \cos \theta_o &= -\sin \varphi \cos (\alpha + \beta) + \cos \varphi \sin (\alpha + \beta) = \\ &= -\sin \varphi + \frac{v_o}{c} \left(\frac{r}{R} + \cos \varphi \right) \cos \varphi. \end{aligned} \quad (30.12)$$

From the figure we further obtain

$$\sin \psi = \frac{v_o \sin \varphi}{v}, \quad \cos \psi = \frac{v_r + v_o \cos \varphi}{v}, \quad (30.13)$$

and from here we get

$$v^2 = v_o^2 + v_r^2 + 2 v_o v_r \cos \varphi. \quad (30.14)$$

Using the last four formulas in the first formula (10.17) and working within an accuracy of second order in $1/c$, we obtain the following relation

$$v_o = v \left(1 - \frac{v_r^2}{2c^2} - \frac{v_o^2}{c^2} \frac{r}{R} \cos \varphi \right). \quad (30.15)$$

If we take into account that it is

$$\frac{r\omega}{v_r} = \frac{R\Omega}{v_o} \quad (30.16)$$

we can write (30.15) in the form

$$v_o = v \left(1 - \frac{v_r^2}{2c^2} - \frac{v_r v_o}{c^2} \frac{\Omega}{\omega} \cos \varphi \right). \quad (30.17)$$

This formula can be proved by the experiment.

Now we shall show that formula (30.17) is already checked experimentally to a certain extent. Indeed, if we suppose $\Omega \ll \omega$, then formula (30.17) shows that with the help of the « rotor » experiment one cannot measure the absolute translational velocity v . Champeney *et al.* (1963) tried to register absolute effects in the « rotor » experiment, since, according to the traditional Newton theory, if a rotor moves with the absolute translational velocity v_o , then the effect is to be described by formula (30.17) which must be written, however, without the factor Ω/ω . The aim of Champeney *et al.* was to measure the Earth's rotational velocity (which is 310 m/s on the 45° parallel). The experiment has shown that v_o must be less than $1,6 \pm 2,8$ m/s, and this result was treated as a new and better verification of the Einstein principle of relativity (with respect to the accuracy of the historical Michelson-Morley experiment).

It is clear that this conclusion is untenable. When we analyse Champeney's experiment with our formula, then we see that if $\Omega = 1,15 \cdot 10^{-5}$ rad/s (the Earth's diurnal angular velocity), $\omega = 1,15 \cdot 10^3$ rad/s (the rotor's angular velocity), $v_o = 310$ m/s, then $(\Omega/\omega) v_o = 3,1 \cdot 10^{-6}$ m/s. This effect is lower than the accuracy of Champeney's experiment by six orders. Since in Nature all motions of the celestial bodies are rotational, then (at least theoretically !) we can establish any such motion, using the « rotor », i.e., the « rotor-rotor » experiment, where the big rotor represents the rotation of the celestial body (about its rotational axis, about the primary, or about the galactic centre).

30.5. THE SANTOS EXPERIMENT

In the « rotor » experiment there is no relative motion between source and observer. With the aim of realizing a transverse Doppler-effect experiment where source and observer have to move with respect to one another, Santos (1976) proposed the following experiment :

Let us have two disks rotating in opposite directions : (i) about two parallel axes, so that the disks lie in the same plane, or (ii) about the same

axis, so that the disks lie in two parallel planes. A γ -ray emitter is placed at the rim of one disk and a γ -ray absorber at the rim of the other, the linear rotational velocity of each being ν . At the moment when their velocities are antiparallel, their relative velocity will be 2ν .

The result of this experiment can be found from formula (10.17), putting there $\theta' = \pi/2$, $\theta_0 = \pi/2$. Within an accuracy of second order in ν/c we obtain

$$\nu_0 = \nu [1 - (\nu^2 - \nu_0^2)/2 c^2], \quad (30.18)$$

and for $\nu = \nu_0$ we get $\nu_0 = \nu$.

It is instructive to note that in the Santos experiment the result is the same for anti-parallel and *parallel* directions of the velocities.

As we showed in Marinov (1977a), because of the inevitable appearance of first-order in ν/c effects, Santos' experiment cannot be practically realized. Indeed, when performing this experiment we have to put between the rotating disks a shielding with length d and aperture b . Assume, for simplicity's sake, the trajectories of emitter and absorber are rectilinear and the shielding exactly perpendicular to them. Since the emitter and absorber are not point objects, then for the different emitting and receiving atoms we shall have (see fig. 10-2)

$$\theta' = \pi/2 \pm b/d, \quad \theta_0 = \pi/2 \pm b/d. \quad (30.19)$$

Putting this into formula (10.17) and assuming $\nu_0 = \nu$, we obtain

$$\Delta\nu = \nu_0 - \nu = \pm \nu \nu b/c d. \quad (30.20)$$

Santos predicts that, when proceeding from the Einstein theory of relativity, his experiment has to give a positive effect $|\Delta\nu| = 2\nu\nu^2/c^2$. Thus the requirement $b/d < \nu/c$ is to be satisfied. Supposing $\nu = 300$ m/s, $d = 10$ cm, we obtain $b < 10^{-5}$ cm. Obviously, such an experiment cannot be practically realized.

It is worth noting that in Santos' experiment the shielding plays a very important role. As already analysed, if this shielding is at rest in the laboratory, being perpendicular to the trajectories of emitter and absorber, the experiment gives a null (traverse) effect. If the shielding is attached to the absorber, there will be a post-traverse Doppler effect, and we shall have $\nu_0 = \nu (1 - 2\nu^2/c^2)$. If the shielding is attached to the emitter, there will be an ante-traverse Doppler effect, and we shall have $\nu_0 = \nu (1 + 2\nu^2/c^2)$.

§ 31. THE QUASI-WIENER « STANDING WAVES » EXPERIMENT

The « standing waves » experiment, considered in detail in Marinov (1978o), represents a modification of the historical Wiener experiment with which Wiener measured the length of light waves in the most direct manner. Its essence is as follows :

Let a light source and an ideal mirror be placed on the x -axis of a given frame K . If this frame is at rest in absolute space (or its absolute velocity is perpendicular to the x -axis), the electric intensities of the incident and reflected by the mirror light waves will be

$$\begin{aligned} E^+ &= E_{\max} \sin(\omega t + kx), \\ E^- &= E_{\max} \sin(\omega t - kx), \end{aligned} \quad (31.1)$$

where E_{\max} is the amplitude of the electric intensity, $\omega (= 2\pi\nu)$ is the circular frequency and $k (= 2\pi\lambda^{-1})$ is the circular wave number; t is the time registered on a clock attached to the frame, i.e., on an absolute clock if frame K is at rest or on a proper clock if it moves with velocity v , omitting in the last case, for brevity's sake, the subscript «_o»; x is the distance from the frame's origin where at the initial zero moment the electric intensities of the incident (+) and reflected (-) waves are equal to zero.

The incident and reflected light waves will interfere. For the electric intensity of the produced standing wave we obtain

$$E = E^+ + E^- = 2 E_{\max} \sin(\omega t) \cos(kx). \quad (31.2)$$

Suppose now that we set frame K in motion with velocity v directed in parallel to the x -axis (or that we rotate the moving frame K so that its velocity v becomes parallel to the x -axis). Instead of ω and k in formula (31.1) we now have to write the quantities [see formulas (10.19) and (10.21)]

$$\omega_o^\pm = \omega, \quad k_o^\pm = \frac{2\pi}{\lambda_o^\pm} = k(1 \pm v/c), \quad (31.3)$$

and for the electric intensity of the produced standing wave we obtain

$$E = E^+ + E^- = 2 E_{\max} \sin\left[\omega\left(t + \frac{v x}{c^2}\right)\right] \cos(kx). \quad (31.4)$$

Hence the distances between the nodes of the standing waves in the cases where the Wiener experiment is performed at rest and in motion with respect to absolute space will be *exactly the same*, and no first- or second-order differences in the pattern will be registered. The unique difference is : When the laboratory is at rest in absolute space (or its velocity is

perpendicular to the direction of light propagation), E obtains its maximum at all antinodes (i.e., for $x = n\pi/k$, where n is an integer) *at the same moment*, and when the velocity of the laboratory is parallel to the direction of light propagation, E obtains its maximum at the different antinodes *at different moments*. For a given moment t the electric intensity in (31.4) obtains its maximum at the antinodes with coordinates near to

$$x = \left(\frac{2n + 1}{\omega} \frac{\pi}{2} - t \right) \frac{c^2}{v}, \quad (31.5)$$

while for this moment t it is zero at the antinodes with coordinates near to

$$x = \left(\frac{n\pi}{\omega} - t \right) \frac{c^2}{v}. \quad (31.6)$$

This is the unique effect which is offered by the quasi-Wiener experiment and we are sceptical about its experimental verification.

We must point out that the historical Michelson-Morley experiment shows immediately that the quasi-Wiener experiment cannot reveal any second-order in v/c effect. Indeed, if the standing waves have different lengths (within terms of second order in v/c) in cases where the pattern is parallel and perpendicular to the absolute velocity, this should signify that different numbers of wavelengths are to be placed in the Michelson-Morley experiment between the semi-transparent mirror and the two mirrors placed at equal distance from it in parallel and perpendicular directions to the absolute motion.

§ 32. THE « COHERENT LASERS » EXPERIMENT

As is well known, the coherence of light emitted by lasers is much higher than the coherence of light emitted by other sources. The coherent length of a laser beam can be hundreds of kilometers, while that of other light sources is only centimeters. For this reason, light emitted by two different lasers can interfere in the same manner as light emitted by a single source and split into two beams interferes if the two beams meet, after having covered slightly different light paths. Before the invention of the laser, a single light source was always used in all optical experiments with whose help an « aether wind » was searched for. The inevitable result was that in all « inertial » experiments (i.e., those performed with inertially moving implements), light beams had to cover the paths « there-and-back » and the first-order in v/c effects always vanished in the final result (as we have shown several times in this book, no second-order effects can appear either). The *unique* interferometric experiment in which first-order in v/c effects have been observed

(excluding our experimental activity !) represents the « rotating disk » experiment where the implement is not moving inertially and the light beams cover closed paths between « splitting » and « meeting », propagating only « there ».

However, if we have two different light sources which produce coherent light, then first-order in v/c experiments can be set up also on inertially moving implements. This was the intention of Carnahan (1962) who proposed the « coherent lasers » experiment, analysed in detail in Marinov (1978p), and also described below.

32.1. THE INERTIAL « COHERENT LASERS » EXPERIMENT

The scheme of the « coherent lasers » experiment (which, if performed in a laboratory, will be called inertial) is as follows (fig. 32-1) :

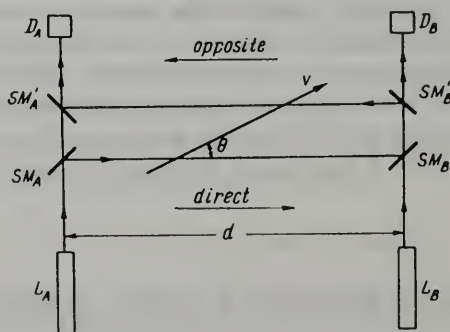

Fig. 32-1

Light emitted from laser L_A (or L_B) is partly reflected and partly refracted by the semi-transparent mirror SM_A (SM_B). The refracted beam proceeding from L_A (L_B) interferes with the reflected beam proceeding from L_B (L_A), after the latter has covered distance d in « opposite » (« direct ») direction and after being reflected by the semi-transparent mirror SM'_A (SM_B). The photodetector D_A (D_B) indicates the result of the interference.

For the sake of simplicity, we shall assume that the semi-transparent mirrors SM_A and SM'_A (SM_B and SM'_B) lie at the same point (see fig. 32-2) which we shall call point A (B).

Let us suppose first that the implement is at rest in absolute space. Let the instantaneous electric intensities of the light beams produced by L_A at point A and by L_B at point B be, respectively,

$$E_A = E_{\max} \sin(\omega_A t + \alpha_A), \quad E_B = E_{\max} \sin(\omega_B t + \alpha_B), \quad (32.1)$$

where

$$\omega_A = \omega + \frac{\Delta\omega}{2} = \frac{2\pi c}{\lambda_A} = \frac{2\pi c}{\lambda - \frac{\Delta\lambda}{2}}, \quad \omega_B = \omega - \frac{\Delta\omega}{2} = \frac{2\pi c}{\lambda_B} = \frac{2\pi c}{\lambda + \frac{\Delta\lambda}{2}} \quad (32.2)$$

are the angular frequencies ($0 < \Delta\omega \ll \omega$), λ_A, λ_B are the wavelengths, α_A, α_B are the initial phases, and we have assumed that the amplitudes E_{\max} in both beams are equal.

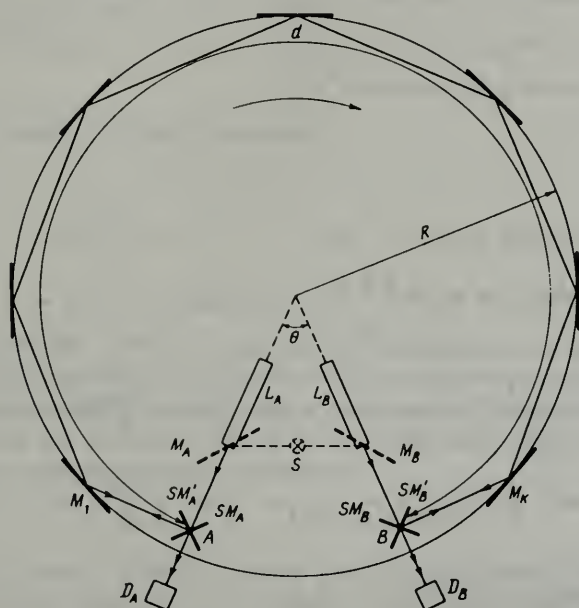

Fig. 32-2

If we wish to find the electric intensities at point A (or point B) after the mixing, we have to add E_A and E_B , taking for the latter an additional phase shift $2\pi d/\lambda_B$ (taking for the former an additional phase shift $2\pi d/\lambda_A$).

Let us now set the implement in motion with velocity v which makes an angle θ with the « direct » direction of its axis. If we wish to find the electric intensity at point A (point B) after the mixing in this case, we have to add E_A and E_B , taking for the latter an additional phase shift $2\pi d/\lambda_{B_0}$ (taking for the former an additional phase shift $2\pi d/\lambda_{A_0}$), where λ_{B_0} (λ_{A_0}) is the observed wavelength of the « opposite » (« direct ») beam. Thus, writing by t the

proper time of a clock attached to the implement (for brevity we omit the subscript « 0 »), we shall obtain for the electric intensities at points A and B , respectively, [see (10.19) and (10.21)]

$$\begin{aligned}
 (E_A + E_B)_A &= , \\
 &= E_{\max} \sin(\omega_A t + \alpha_A) + E_{\max} \sin\left(\omega_B t + \alpha_B + \frac{2\pi d}{\lambda_{B0}}\right) = \\
 &= 2 E_{\max} \sin\left\{\frac{1}{2} \left[2\omega t + \alpha_A + \alpha_B + \frac{d}{c}\left(\omega - \frac{\Delta\omega}{2}\right)\left(1 - \frac{v}{c} \cos\theta\right)\right]\right\} \cdot \\
 &\quad \cdot \cos\left\{\frac{1}{2} \left[\Delta\omega t + \alpha_A - \alpha_B - \frac{d}{c}\left(\omega - \frac{\Delta\omega}{2}\right)\left(1 - \frac{v}{c} \cos\theta\right)\right]\right\} = \\
 &= 2 E_{\max} \cos\left(\frac{1}{2} \varphi_A\right) \sin(\omega t + \beta_A) \tag{32.3}
 \end{aligned}$$

and

$$\begin{aligned}
 (E_A + E_B)_B &= \\
 &= E_{\max} \sin\left(\omega_A t + \alpha_A + \frac{2\pi d}{\lambda_{A0}}\right) + E_{\max} \sin(\omega_B t + \alpha_B) = \\
 &= 2 E_{\max} \sin\left\{\frac{1}{2} \left[2\omega t + \alpha_A + \alpha_B + \frac{d}{c}\left(\omega + \frac{\Delta\omega}{2}\right)\left(1 + \frac{v}{c} \cos\theta\right)\right]\right\} \cdot \\
 &\quad \cdot \cos\left\{\frac{1}{2} \left[\Delta\omega t + \alpha_A - \alpha_B + \frac{d}{c}\left(\omega + \frac{\Delta\omega}{2}\right)\left(1 + \frac{v}{c} \cos\theta\right)\right]\right\} = \\
 &= 2 E_{\max} \cos\left(\frac{1}{2} \varphi_B\right) \sin(\omega t + \beta_B). \tag{32.4}
 \end{aligned}$$

Let the photodetectors transform the incident light intensity into electric tension which we lead to a point (call it point C) in the middle between points A and B . Designate by U_A, U_B the electric tensions on the outputs of the detectors D_A, D_B . Since U_A, U_B are proportional to the squares of the variable amplitudes of $(E_A + E_B)_A$ and $(E_A + E_B)_B$, we can write

$$\begin{aligned}
 U_A &= U_{\max} \cos^2\left(\frac{1}{2} \varphi_A\right) = \frac{1}{2} U_{\max} (1 + \cos \varphi_A), \\
 U_B &= U_{\max} \cos^2\left(\frac{1}{2} \varphi_B\right) = \frac{1}{2} U_{\max} (1 + \cos \varphi_B), \tag{32.5}
 \end{aligned}$$

where U_{\max} is the amplitude of the electric tension whose angular frequency is $\Delta\omega$.

Leading the electric tensions U_A, U_B to the middle point C and taking into account the additional phase shifts for U_A and U_B because of the different velocities of propagation of the electromagnetic energy in « direct » and « opposite » directions, we obtain for their sum

$$\begin{aligned} (U_A + U_B)_C &= \frac{1}{2} U_{\max} \left\{ 1 + \cos \left[\varphi_A + \frac{d}{2c} \Delta\omega \left(1 + \frac{v}{c} \cos \theta \right) \right] \right\} + \\ &+ \frac{1}{2} U_{\max} \left\{ 1 + \cos \left[\varphi_B + \frac{d}{2c} \Delta\omega \left(1 - \frac{v}{c} \cos \theta \right) \right] \right\} = \\ &= U_{\max} \left\{ \cos \left(\Delta\omega t + \alpha_A - \alpha_B + \frac{d}{c} \Delta\omega + \frac{d}{c^2} \omega v \cos \theta \right) \cos \left(\frac{d}{c} \omega \right) \right\}. \end{aligned} \quad (32.6)$$

Let us analyse this result. Obviously

$$\cos \frac{2\pi d}{\lambda} = \begin{cases} +1 & \text{for } d = n\lambda, \\ -1 & \text{for } d = (n \pm 1/2)\lambda, \\ 0 & \text{for } d = (n \pm 1/4)\lambda, \end{cases} \quad (32.7)$$

n being an integer. Thus the « percentage modulation » of the resultant electric tension depends on the number of the average wavelengths λ placed along distance d . Hence, to be able to measure a change $v \cos \theta$ in the component of the absolute velocity of the implement along its axis, the following two conditions must be available

$$\Delta\omega = 0, \quad d \neq (n \pm 1/4)\lambda. \quad (32.8)$$

In such a case, if during a definite time the component of the absolute velocity of the implement along its axis changes from 0 to $v \cos \theta$, this will lead to a phase shift in the argument of the resultant electric tension equal to $d\omega v \cos \theta / c^2$ radians, assuming that during this time the initial phases α_A, α_B remain constant.

However, as we show in Marinov (1978p), if we take into account the absolute time dilation, then it can easily be established (in a manner *very similar* to that used in §22.3) that when rotating the implement with respect to its absolute velocity, i.e., when « switching on an aether wind by rotation », the initial phases of the lasers do not remain constant. They change *exactly* in such a way that the absolute effect, which a traditional absolutist expects to be registered, will be annihilated.

Thus, with the « coherent lasers » experiment, we can measure only a *real* change in the velocity of the implement. The experiment is to be performed as follows : Assuming that the conditions (32.8) are fulfilled, let us measure some phase α of the electric tension $(U_A + U_B)_C$. If we know α_A, α_B , we can calculate $v \cos\theta$. However, the initial phases of the lasers are unknown. Let us then set the implement in motion with a certain velocity v along the « direct » direction. If the new phase which we should measure is α' , it will be

$$\alpha' - \alpha = \frac{d}{c^2} \omega v, \quad (32.9)$$

which corresponds to the following change in the sum of the phase shifts of the electric tensions U_A and U_B

$$(\varphi'_A - \varphi_A) + (\varphi'_B - \varphi_B) = \frac{2d}{c^2} \omega v. \quad (32.10)$$

Taking $\omega/2\pi = 5.10^{14}$ Hz, $d = 1$ m, $v = 45$ m/s = 162 km/h, we obtain a phase shift in the argument of the resultant electric tension $\alpha' - \alpha = \pi/2$.

32.2. THE « COHERENT LASERS ON A ROTATING DISK » EXPERIMENT

To show more clearly why the inertial « coherent lasers » experiment is to be explained in the manner presented in §32.1, we shall consider the « coherent lasers on a rotating disk » experiment (Marinov, 1978p) whose essence is as follows (fig. 32-2) :

Let us mount the implement from fig. 32-1 on a rotating disk and measure the electric tensions U_A, U_B on the outputs of the detectors D_A, D_B . Let the first condition (32.8) be fulfilled. If the disk is first at rest and then set in rotation in a clockwise direction with a linear rotational velocity of its rim v , then the arguments of U_A and U_B will obtain additional phase shifts [see formulas (32.3), (32.4), (32.5)] whose sum is given by formula (32.10). This « coherent lasers on a rotating disk » experiment is analogical to the « rotating disk » experiment, as can be seen immediately from fig. 32-2 if both lasers should be replaced by a unique light source S and the mirrors M_A, M_B .

The substantial difference between the « rotating disk » experiment and the « coherent lasers on a rotating disk » experiment consists in the fact that there are *two* sources emitting coherent light in the latter, while there is a *unique* light source in the former. Thus if we should make angle θ in fig. 32-2 almost equal to 2π and the source S is very near to the rim of the disk, then the « rotating disk » experiment cannot give any positive effect because the time lags which should appear along path d will be compensated by the

opposite time lags which will appear along the paths from S to M_A and M_B . However, the « coherent lasers on a rotating disk » experiment will always (at any angle θ in fig. 32-2) give the result (32.10) because both coherent light sources are here *spatially separated* and, when « switching on the aether wind », i.e., when setting the disk in rotation, the difference in the initial phases of both lasers *cannot* change because both lasers move all the time with the *same* absolute velocity.

Remember that to obtain a positive effect in the « rotating disk » experiment at any angle θ , the source must be placed at the centre of rotation (see §26).

32.3. THE CONNECTION BETWEEN THE « COHERENT LASERS » AND LIGHT DOPPLER-EFFECT EXPERIMENTS

As technology cannot yet produce a laser with a high enough frequency stability [Letohov and Chebotaev (1974) have achieved stability $\delta\omega/\omega = 10^{-14}$ for 100 seconds], the « coherent lasers » experiment cannot be performed under the condition $\Delta\omega \cong 0$. Indeed, to perform it under this condition one must have two lasers whose frequencies can differ from one another and vary with [see (32.9)]

$$\delta\omega < \frac{\alpha' - \alpha}{t}, \quad (32.11)$$

where t is the time of measurement in which the velocity of the implement changes from 0 to v . At the condition (32.11), the measuring error could be at most as large as the effect to be measured. Choosing $\alpha' - \alpha = \pi/2$ rad, $t = 100$ s, we obtain $\delta\omega < (\pi/2)10^{-2}$ rad/s, while (assuming $\omega = \pi \cdot 10^{15}$ rad/s) the frequency instability mentioned above leads to $\delta\omega = \pi \cdot 10$ rad/s for any of the lasers.

Let us now analyse the « coherent lasers » experiment from a slightly different point of view which will show that it is not necessary to spend time and effort in its performance because, as we shall show, it has already been carried out in a very similar arrangement and has given the result predicted by us.

If we move the implement with a constant acceleration u , the velocity after any time interval t will be $v = ut$. Putting this into (32.6) and assuming

$$\theta = 0, \quad d = n\lambda, \quad \alpha_A - \alpha_B + \frac{d}{c} \Delta\omega = 2\pi n, \quad (32.12)$$

we obtain

$$(U_A + U_B)_C = 2 U_{\max} \cos^2 \left[\frac{1}{2} (\Delta\omega + \Omega) t \right], \quad (32.13)$$

where

$$\Omega = \frac{d}{c^2} \omega u \quad (32.14)$$

represents some additional frequency increase.

Thus, when accelerating the implement, the frequency of the resultant electric tension should increase (we repeat, the acceleration is along the axis of the implement). Taking the data given after formula (32.10) and $t = 100$ s, i.e., $u = 45$ cm/s², we obtain $\Omega = (\pi/2)10^{-2}$ rad/s. Hence the lasers can now have different frequencies ω_A , ω_B , and a change in the « beat » frequency $\Delta\omega$ is to be registered. Nevertheless, since it must be $\delta\omega < \Omega$, we have to conclude that also this accelerated « coherent lasers » experiment cannot be performed at the present state of technique.

However, there is no need to perform it because this would be only a repetition of Bömmel's (1962) experiment where the frequency change (32.14) was established by using the Mössbauer effect and by accelerating a gamma emitter and absorber with $u = 10^6$ m/s². The accuracy of the Mössbauer effect ($\delta\omega/\omega = 10^{-12}$) is not higher than that of lasers, however, such large accelerations cannot be realized with lasers.

The essence of Bömmel's experiment and of our accelerated « coherent lasers » experiment is the same. Since the emitter (say, mirror SM'_B in fig. 32-1) and the receiver (mirror SM'_A) move with acceleration, then, as a result of the Doppler effect, the frequency received will differ from the emitted one. Indeed, as there is a certain time during which light has to cover distance d , the velocity of the receiver at the reception moment will be different (higher for u pointing along the emitter-receiver line) from the velocity of the emitter at the emission moment. Einstein (1911) pointed to this simple and clear physical phenomenon many years before its experimental confirmation.

The analysis of the « coherent lasers » experiment given here allows one to understand that when the emitter and receiver move with acceleration, then the shift in the received frequency leads to an additional phase shift $\alpha' - \alpha$ which is equal to the product of the frequency shift Ω and the time t of accelerated motion. Thus the number of light waves (wavelengths) placed along the distance between emitter and receiver changes (the number increases for $c \uparrow u$ and decreases for $c \downarrow u$). Hence, as the velocity of light is the product of frequency and wavelength, then light velocity will be different for different velocities of the implement (with respect to the implement) because the frequency received remains unchanged.

§ 33. THE « WIRED PHOTOCELLS » EXPERIMENT

The « wired photocells » experiment, performed first by Godart (1974), is considered by us in detail in Marinov (1978q). We review this paper here.

33.1. THE INERTIAL « WIRED PHOTOCELLS » EXPERIMENT

The essence of the « wired photocells » experiment (which, if performed in a laboratory, is called inertial) is as follows (fig. 33-1) :

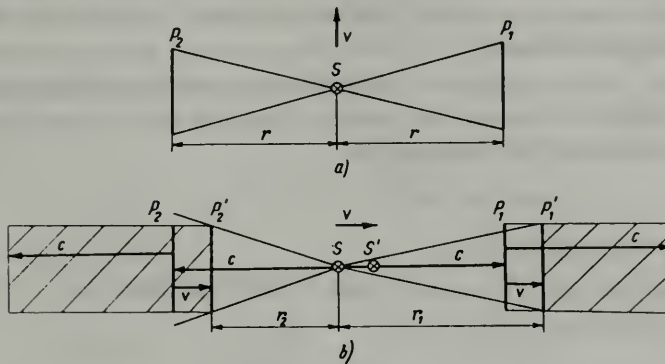

Fig. 33-1

Two photocells P_1, P_2 were put on the opposite sides of a light source S (an electric bulb). The cells and the bulb were mounted on an optical bench and covered with a light-tight cloth. The cells were wired to each other and to a galvanometer in such a way that only the difference in current between the cells flowed through the galvanometer. In our realization, all elements (excluding the galvanometer) were mounted on a wheeled table which could rotate. Godart (1974) claims that by rotating such an implement, increased current is to be observed when the axis of the implement is aligned approximately north-south. In our realization during a rotation of 360° , we registered *no* effect.

This negative (null) effect was explained by us as a result of the mutual annihilation of the « aether wind » effect (analysed in §33.2) and the effect of relativistic distribution of the radiation (analysed in §33.3), as is the case in a number of high-velocity experiments analysed already in this book.

We proved our assertion about the mutual annihilation of these two high-velocity absolute effects in the « wired photocells » experiment, performing the « wired photocells on a rotating disk » experiment which is reported in §33.4.

33.2. THE « AETHER WIND » EFFECT

Fig. 33-1a demonstrates the case where the absolute velocity v of the laboratory is perpendicular to the axis of the apparatus; when the light source is at the middle position between the photocells P_1 and P_2 no current will flow through the galvanometer.

Let us rotate the axis of the implement so that the absolute velocity of the laboratory will be pointing from P_2 to P_1 (fig. 33-1b). Now, proceeding from the aether conception for light propagation, we conclude that in a unit of time more photons will strike P_2 . Thus the currents produced by the photocells will be $J_1 = J - \Delta J/2$, $J_2 = J + \Delta J/2$, where J is the current produced by them in the case a, and the difference in current ΔJ will flow through the galvanometer.

Indeed, now the « effective » distances of the photocells from the source (i.e., the distances between the emission position of the source and the reception positions of the cells) will be

$$r_1 = r(1 + v/c), \quad r_2 = r(1 - v/c), \quad (33.1)$$

where r is the actual distance.

Hence the energy flux density over P_1 and P_2 will be :

a) For the case in fig. 33-1a

$$I = \frac{P}{4\pi r^2}, \quad (33.2)$$

where P is the energy flux radiated by the whole light source (for simplicity we suppose the source as a point and the radiation isotropic).

b) For the case in fig. 33-1b

$$I'_1 = \frac{P}{4\pi r_1^2} = \frac{P}{4\pi r^2(1 + v/c)^2}, \quad I'_2 = \frac{P}{4\pi r_2^2} = \frac{P}{4\pi r^2(1 - v/c)^2} \quad (33.3)$$

However, we also have to take into account that cell P_1 will collect in a unit of time all photons in a cylinder (suppose the photocells circular) whose axis is equal to c minus the photons in the cylinder $P_1P'_1$ whose axis is equal to v , while the cell P_2 will collect in a unit of time all photons in a cylinder whose axis is equal to c plus the photons in the cylinder $P_2P'_2$ whose axis is equal to v . Thus the actual energy flux densities will be

$$I_1 = \frac{I'_1}{1 + v/c} = \frac{P}{4\pi r^2(1 + v/c)^3}, \quad I_2 = \frac{I'_2}{1 - v/c} = \frac{P}{4\pi r^2(1 - v/c)^3} \quad (33.4)$$

Indeed, the photons which strike P_1 and P_2 have velocity [see formula (3.32)]

$$c'_0 = c \quad (33.5)$$

for the case **a** and, respectively, velocities

$$c'_{10} = \frac{c}{1 + v/c}, \quad c'_{20} = \frac{c}{1 - v/c} \quad (33.6)$$

for the case **b**, if these velocities are measured on a proper clock. Thus we shall have

$$I_1/c'_{10} = I'_1/c'_0, \quad I_2/c'_{20} = I'_2/c'_0, \quad (33.7)$$

and from the last three formulas we obtain (33.4).

Since the electric currents produced by the photocells are proportional to the energy flux densities, we shall have :

a) For the case in fig. 33-1a

$$J = k I = \frac{k P}{4 \pi r^2}, \quad (33.8)$$

where k is a constant.

b) For the case in fig. 33-1b

$$J_1 = k I_1 = \frac{k P}{4 \pi r^2 (1 + v/c)^3} = \frac{J}{(1 + v/c)^3}, \quad (33.9)$$

$$J_2 = k I_2 = \frac{k P}{4 \pi r^2 (1 - v/c)^3} = \frac{J}{(1 - v/c)^3},$$

For their difference we obtain within an accuracy of first order in v/c

$$\Delta J = J_2 - J_1 = 6 J \frac{v}{c}. \quad (33.10)$$

In our realization of the « wired photocells » experiment, it was $J = 5 \cdot 10^{-4}$ A and thus it had to be $\Delta J = 10^{-8}$ A for $v = 1$ km/s. Since the fluctuation shift was lower than 10^{-8} A, we have thus established that the component of the Earth's absolute velocity in the plane of rotation of the implement must be less than 1 km/s (we performed the experiment during different hours of the day). However, taking into account the result of our interferometric « coupled-mirrors » experiment (§19.2), we have to conclude that the « wired photocells » experiment gives a negative (null) result.

Let us note that if we take into account *only* the effect described by formula (33.3), i.e., the effect

$$\Delta J' = J'_2 - J'_1 = 4 J \frac{v}{c}, \quad (33.11)$$

then it will be the *same* as the effect obtained by a shift of the light source to the photocell P_2 over a (v/c) th part of the distance r . Assuming $v = 300$ km/s and taking into account that we had $r = 500$ mm, we obtain that for such a velocity the « aether wind » effect described by formula (33.11) is to be the same as the effect provoked by a shift of the light source over a distance $\Delta r = (v/c)r = 0,5$ mm. Such a shift of the electric bulb has provoked an electric current ΔJ of about $2 \cdot 10^{-6}$ A.

33.3. THE EFFECT OF RELATIVISTIC DISTRIBUTION IN THE RADIATION

We explain the negative (null) result in the « wired photocells » experiment, taking into account the relativistic distribution in the radiation flux density of a rapidly moving light source. Such an effect has already been observed in betatrons and synchrotrons where the radiants are elementary particles. We assume that the same effect must exist also when the radiant is a macroscopic light source and we have confirmed this assumption with the help of the « wired photocells on a rotating disk » experiment (see §33.4).

The theory of the relativistic distribution in the radiation of a macroscopic light source is given in Marinov (1978q). Since in the treatment of this phenomenon a heavier mathematical apparatus is needed, we shall merely direct the interested reader to our original publication. Our theoretical analysis (Marinov, 1978q) shows that the effect of the relativistic distribution in the radiation is exactly equal and opposite to the « aether wind » effect, i.e., the energy flux densities over P_1 and P_2 are given :

- a) For the case shown in fig. 33-1a by the formula (33.2).
- b) For the case shown in fig. 33-1b by the following formulas

$$I_1 = \frac{P}{4 \pi r^2 (1 - v/c)^3}, \quad I_2 = \frac{P}{4 \pi r^2 (1 + v/c)^3}. \quad (33.12)$$

Thus, as a result of these two effects [compare formulas (33.9) and (33.12)], no positive absolute effect can be observed in the « wired photocells » experiment.

33.4. THE « WIRED PHOTOCELLS ON A ROTATING DISK » EXPERIMENT

We have proved our theoretical prediction about the mutual annihilation of the absolute effects described in §33.2 and §33.3 by the help of the « wired photocells on a rotating disk » experiment whose scheme is the following (fig. 33-2) :

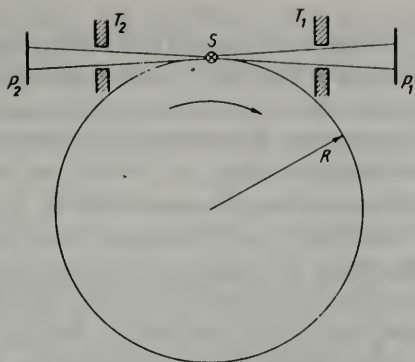

Fig. 33-2

The source S and/or the photocells P_1 , P_2 can be mounted on a turnabout which rotates clockwise. T_1 and T_2 are two slits which are *always* at rest. All other details are as in the « wired photocells » experiment.

We have performed this experiment in three variants :

a) Source moving, cells at rest. In such a case one registers only the effect of relativistic distribution in the radiation described by formulas (33.12), and for the relative change of the difference in current we obtain [cf. with (33.9) and (33.10), taking into account that now $\Delta J = J_1 - J_2 > 0$]

$$\frac{\Delta J}{J} = 6 \frac{v}{c} . \quad (33.13)$$

b) Cells moving, source at rest. In such a case one registers only the « aether wind » effect described by formulas (33.7), and for the relative change of the difference in current ΔJ we obtain ($\Delta J = J_2 - J_1 > 0$)

$$\frac{\Delta J}{J} = 2 \frac{v}{c} , \quad (33.14)$$

since now the « aether wind » effect described by formulas (33.3) — see formula (33.11) — does not exist.

c) Source and cells moving. In such a case the effects described by formulas (33.4) and (33.12) appear together and one registers no change in the difference in current when changing the velocity of rotation.

In all formulas relevant to the « wired photocells on a rotating disk » experiment, v is the component of the velocity of the source or the cells or both along the line of light propagation. Thus, supposing that the slits are narrow enough, we can assume that this is the velocity of a point on the rotating disk whose radius R is equal to the distance from the centre of rotation to the centre of the light source.

In our realization, we used a stabilized gas discharge lamp as a light source. The conductors from the lamp and from the photocells were immersed in mercury at the centre of the disk, so we did not register a substantial difference in the fluctuation of the galvanometer at rest and at rotation of the disk. The difference in current ΔJ was fed to a direct-current electronic amplifier with a low resistance input (i.e., which can be considered as a galvanometer) whose fluctuation corresponded to $\delta J = \pm 3,3 \cdot 10^{-12}$ A (at maximum rotational velocities). At low rotational velocities the current J was periodically (with the period of rotation) increasing (when the cells were illuminated) and decreasing. At a rate of rotation higher than 5 rev/s the current was stable, equal to $6,5 \cdot 10^{-5}$ A and did not change with the increase of the rate of rotation. For low rotational velocities, a slight « single-sinusoidal » difference in current ΔJ was also observed. The distance of the lamp from the centre of rotation (measuring from the centre of the lamp's windows) was $R = 79,6 \pm 0,2$ cm and the distance of the cells about 98 cm. The rate of rotation N was measured by a light stroboscopic cyclometer and maintained automatically with a precision $\delta N/N = \pm 2 \cdot 10^{-4}$. We made the difference in current to be zero for $v/c = 10^{-7}$ — this corresponded to a rotational rate $N = 6,00$ rev/s — by a corresponding shift of the cells (case a) or of the lamp (case b). For case c, ΔJ was made equal to zero when lamp and cells were at rest.

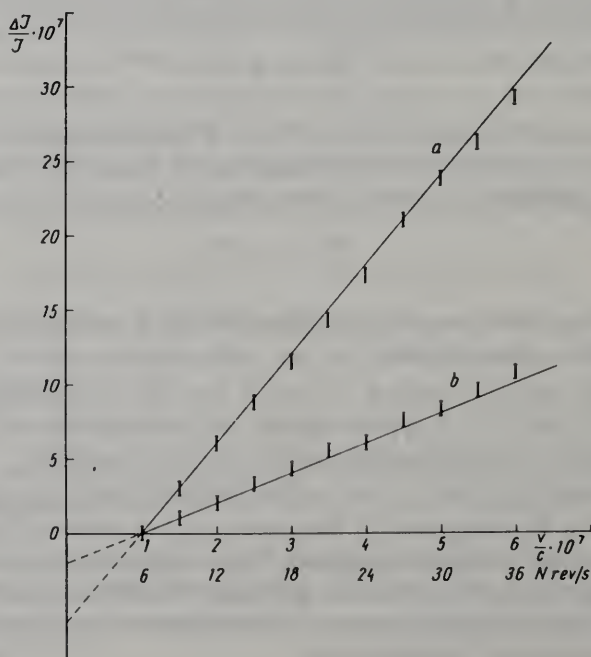

Fig. 33-3

In fig. 33-3 we give the results of our measurements for cases a and b. For case c no difference in current was registered which could be discerned from the fluctuation.

It is obvious that our working formulas were not (33.13) and (33.14) but

$$\frac{\Delta J}{J} = 6 \left(\frac{v}{c} - 10^{-7} \right), \quad \frac{\Delta J}{J} = 2 \left(\frac{v}{c} - 10^{-7} \right). \quad (33.15)$$

In the graphs, we give only the fluctuation errors. The errors introduced by the inaccuracy δN are too small to be discussed. Also, we do not take into account the errors introduced by the inaccuracy $\delta R = \pm 0,2$ cm, because its relative error is $\pm 0,25$ %, while the *minimum* relative error due to the fluctuation (for $v/c = 6 \cdot 10^{-7}$ in case a) is $\pm 1,7$ %.

§ 34. THE « CAULDRON » EXPERIMENT

We have proposed the « cauldron » experiment in Marinov (1978r) with the aim of showing not only that light propagation phenomena are absolute but also all electromagnetic phenomena. Thus electromagnetic experiments can be set up to help register the absolute velocity of the laboratory.

The essence of the « cauldron » experiment is as follows (fig. 34-1) :

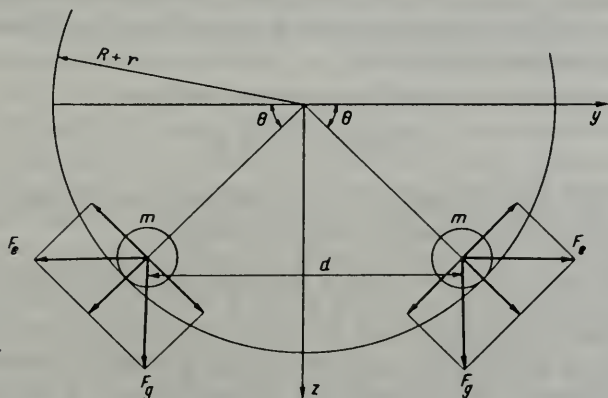

Fig. 34-1

Let us have two homogeneous spheres with masses m and radii r , charged homogeneously with electric charges q , which can roll along the inner surface of a sphere (a « cauldron ») with radius $R + r$. Let the x -axis (with unit vector x^0) point behind the figure, the y -axis (with unit vector y^0) to

the right and the z -axis (with unit vector z^0) downwards to the Earth's centre. The masses lie in the yz -plane and, for the sake of simplicity, we suppose that the absolute velocity of the laboratory is parallel to the xz -plane. If we do not take into account the mutual gravitational attraction between our masses and the attraction caused by the other celestial bodies, then the following two forces will act on any of these masses :

a) The full gravimagnetic force caused by the gravimagnetic interaction with the Earth whose mass is M [write the Newton-Marinov equation (8.5) in a form analogical to (7.3) and take into account that for the case considered $dA_g/dt = 0$]

$$\vec{F}_g = m_0 \text{grad} \left(\gamma \frac{M_0}{D} - \gamma \frac{M_0 v^2}{c^2 D} \right) = \gamma \frac{mM}{D^2} z^0 = \vec{F}_g z^0, \quad (34.1)$$

where m_0 is the proper mass of any of the small masses, M_0 is the proper mass of the Earth, D is the distance between their centres and v is the velocity of the Earth (we ignore the rotational velocity about its axis).

b) The full electromagnetic force caused by the mutual electromagnetic interaction between the charges of our masses [see formula (7.3) and take into account that for the case considered $dA/dt = 0$]

$$\vec{F}_e = -q \text{grad} \left(\frac{q}{d} - \frac{q v^2}{c^2 d} \right) = \pm \frac{q^2}{d^2} \left(1 - \frac{v^2}{c^2} \right) y^0 = \pm \vec{F}_e y^0, \quad (34.2)$$

where the sign « + » is for the electromagnetic force acting on the right mass, the sign « - » is for the electromagnetic force acting on the left mass, and d is the distance between their centres.

The masses will be in equilibrium at the condition

$$\vec{F}_g \cos \theta = \vec{F}_e \sin \theta, \quad (34.3)$$

where θ is the angle between the horizontal plane and the radius pointing from the centre of the cauldron to any of our masses.

Suppose now that the velocity of the cauldron has changed with $\Delta v > 0$ because of the yearly motion of the Earth. It is easy to see that the electromagnetic forces will change and a new state of equilibrium will be installed, so that angle θ will change with $\Delta \theta > 0$ and distance d will change with $\Delta d = -2\Delta \theta R \sin \theta < 0$ (we ignore the change ΔD as it is very small with respect to D).

From (34.3) and the equation which we can write for the new state of equilibrium, we obtain within the necessary accuracy

$$\Delta \theta = \frac{v \Delta v}{c^2} \cot \theta. \quad (34.4)$$

Assuming the Earth's absolute velocity to be $v = 300$ km/s, we obtain a yearly variation about the state of equilibrium (for $\Delta v = \pm 30$ km/s and $\theta = \pi/4$)

$$\theta_{\text{year}} = \frac{v \Delta v}{c^2} = \pm 10^{-7}. \quad (34.5)$$

This experiment is difficult to realize. By the light lever of Jones (1975), angles until 10^{-11} rad can be measured. However, there are difficulties in producing spheres (very likely one has to use electrets) which have to maintain a constant charge for a whole year.

Nevertheless, this experiment is extremely fruitful for theoretical physics as a thought experiment :

1) It shows that magnetism is not a relative but an absolute phenomenon. Indeed, according to the principle of relativity, no variations about the state of equilibrium are to be observed when the absolute velocity of the apparatus changes. This, however, contradicts the everyday fact that when changing the velocity of the electrons in a vacuum tube their magnetic field also changes.

2) If the « relativists » consent that the electromagnetic force between two charges changes when they are set in motion (because of the appearing magnetic force), then the principle of relativity will *automatically* fail, if considering the « cauldron » experiment only as a thought experiment. Indeed, if we are on a ship sailing with velocity v in a canal, and we move our cauldron with velocity v (relatively to the ship) first towards the stern and then with the same velocity towards the prow. then an observer-relativist on the ship will conclude that the stern-bound and prow-bound states of equilibrium must be the same and different from the rest state of equilibrium where the cauldron is at rest with respect to the ship. However, another observer-relativist on the bank will conclude that all three states of equilibrium must be different (remember the « clocks-round-the-world » experiment — §22.2). It is clear that the experiment can have a *unique* result as predicted by an observer-absolutist who is at rest in absolute space.

3) The « cauldron » experiment can throw abundant light on the law of gravitational attraction. If gravitation is a « Newtonian » analogue of electromagnetism, i.e., if there is a gravitational analogue to the magnetic energy and the *masses* are responsible for the gravimagnetic interaction of the bodies, then no yearly variation will be observed. However, if gravitation is a « Marinov » analogue of electromagnetism, i.e., if there is a gravitational analogue to the magnetic energy and the *proper masses* are responsible for the gravimagnetic interaction of the bodies, then a yearly variation as described above will be observed. The same yearly variation will be observed

also in the case if there is no gravitational analogue to the magnetic energy and the masses are responsible for the gravitational interaction of the bodies (as was assumed by Newton).

§ 35. THE TROUTON-NOBLE EXPERIMENT

The historical Trouton-Noble (1903) experiment is generally considered as one of the most important experiments to prove the principle of relativity for electromagnetic phenomena.

One expects a positive effect in the Trouton-Noble experiment, accepting that Newton's third law breaks down in the domain of electromagnetism. However, as we have shown in §6, Newton's third law has an universal validity and holds good also in the domain of electromagnetism. Thus the positive effect, which conventional physics predicts in the Trouton-Noble experiment, is based on wrong theoretical calculations. We present here the theoretical analysis and description of the Trouton-Noble experiment given by Jánossy (1971), taking §82 and §83 of his book *in toto* :

82. Consider two opposite point charges $-e$ and $+e$; the radius vector pointing from $-e$ to $+e$ be denoted by r . If the charges are at rest the force acting upon $+e$ can be written

$$F_0 = eE = -\frac{e^2 r}{r^3}.$$

As the force acts in the direction of r the moment of force produced by the pair of charges vanishes, i.e.,

$$M_0 = r \times F_0 = 0.$$

If the pair of charges is made to move with a constant velocity \mathbf{v} , then the positive charge will be under the action of the Coulomb attraction of $-e$ and also under the influence of the magnetic field

$$B = \frac{e}{c} (\mathbf{v} \times \mathbf{r})/r^3.$$

Thus the total force acting upon e is given by

$$F(\mathbf{v}) = e(E + \frac{1}{c} \mathbf{v} \times B) = F_0 + \frac{e^2}{c^2 r^3} \mathbf{v} \times (\mathbf{v} \times \mathbf{r}).$$

Since

$$\mathbf{v} \times (\mathbf{v} \times \mathbf{r}) = \mathbf{v}(\mathbf{v} \cdot \mathbf{r}) - v^2 \mathbf{r},$$

we find that the moment of force produced by the pair of charges is equal to

$$M(\mathbf{v}) = \mathbf{r} \times \mathbf{F}(\mathbf{v}) = \frac{e^2}{c^2} (\mathbf{v} \cdot \mathbf{r}) (\mathbf{r} \times \mathbf{v}) / r^3.$$

Denoting the angle between \mathbf{v} and \mathbf{r} by θ , we find for the absolute value of the moment of force

$$M = \frac{e^2 v^2}{2rc^2} \sin(2\theta). \quad (26)$$

In the above derivation we have neglected the effects of retardation. A more detailed calculation shows that the latter effects give only a negligible correction to (26).

83. In the actual experiment a charged condenser was suspended on an elastic string. The condenser was placed so that $\theta = 45^\circ$, i.e., so that the line perpendicular to the surface of the condenser plates subtended an angle of 45° with the supposed direction of the orbital velocity of the Earth, the direction of \mathbf{v} .

If the moment (26) exists then the elastic fibre upon which the condenser is suspended is twisted to such an extent that the elastic stress arising in the fibre compensates the moment M exerted by the condenser. Turning the condenser together with its support by 90° the moment M changes its sign and so the equilibrium is expected to be disturbed.

In the actual experimental arrangement the condenser was suspended and it was watched whether or not it would change its orientation while the Earth was turning round and therefore the orientation of the condenser relative to the direction of motion of the Earth would change.

The actual experiment showed no such changes in orientation.

The negative outcome of the Trouton-Noble experiment can be interpreted by supposing that the motion of the system relative to the aether produces not only an electromagnetic moment of force but also elastic stresses which compensate exactly the electromagnetic moment of force.

Our explanation of the negative outcome of the Trouton-Noble experiment is as follows (see §6.2 and §7.1) :

During the rotation of the Earth, the total time derivatives of the magnetic potentials caused by both electric charges considered above are equal to zero (the distance between these two charges as well as their velocity do not change !). Thus the full electromagnetic forces acting on them are equal to the corresponding kinetic forces. On the other hand, according to the full Newton's third law, the full electromagnetic forces acting on two isolated charges are equal and oppositely directed along the line connecting them, and no rotational moment of force can be produced by these two charges. Jánossy (as well as conventional physics) does not take into account that when one of the charges moves, the reference point where the other charge is placed also moves, and he calculates the effect in the Trouton-Noble experiment by the help of inappropriate formulas. Our formula (34.2) is the right one to be used in this case.

§ 36. THE « SYNCHROTRON » EXPERIMENT

We have proposed the « synchrotron » experiment in Marinov (1977b) with the aim of showing that the ballistic (Ritz) model of light propagation is not adequate to physical reality, i.e., that the velocity of light is always equal to c (with respect to absolute space !) but not to the geometrical sum of c and the velocity v of the emitter.

The essence of the « synchrotron » experiment, which arose from an outline given by Karastoyanov (1972), is as follows (fig. 36-1) :

Let us have a circular accelerator of electrons A . Short light pulses (packages of photons) are emitted by the emitter E in regular short intervals of time ΔT . These light pulses, after being reflected by the semi-transparent mirror M , pass through the narrow slit S and reach the electrons revolving in the accelerator along the tangent to their trajectory. The photons, after being reflected by the electrons, turn back and, passing through the semi-transparent mirror M , are registered by the receiver R .

We can consider the revolving electrons (representing, as a matter of fact, a fast moving mirror — see §13.3) as a new source of radiation. Changing the velocity of the electrons, we change the velocity of this light source. If the velocity of light depends on the velocity of the source of radiation, then, with the increase of the velocity v of the revolving electrons, the time for which the photons will cover the distance from the accelerator to mirror M will become shorter. Hence if we obtain electric pulses from the emitted and received light pulses and if we lead them to the electrodes of an electronic oscillograph Osc , on its screen we should see the picture shown in the figure. Let the high peaks described by the electronic beam correspond to the

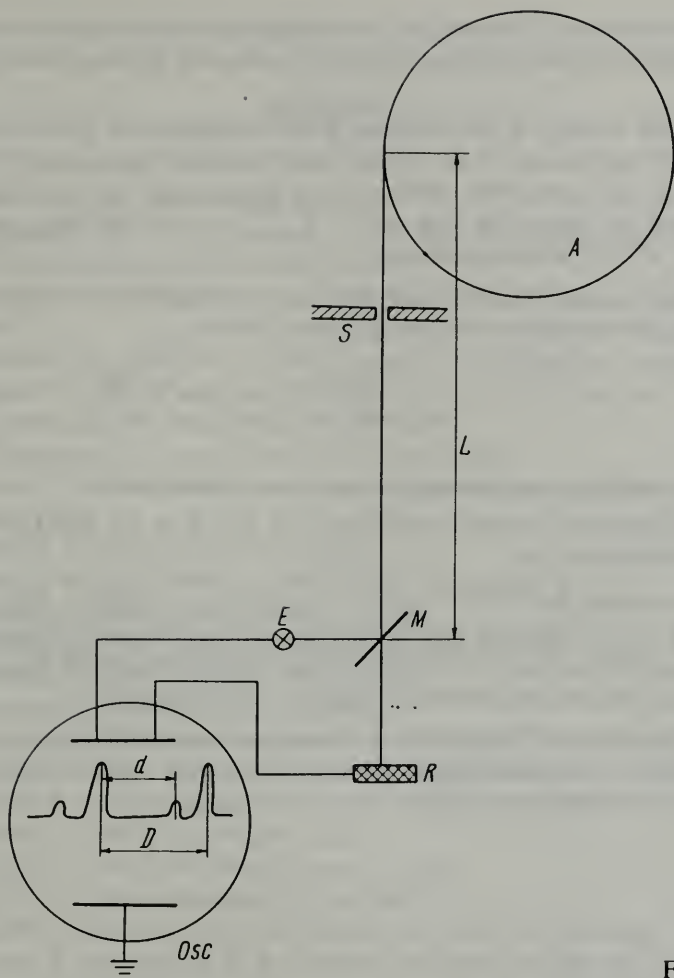

Fig. 36-1

emitted light pulses and the low peaks to the received light pulses. If the velocity of light does not depend on the velocity of the source of radiation, the distance d between the high and low peaks will remain the same when the velocity of the electrons along the circular trajectory of the accelerator increases. If the velocity of light depends on the velocity of the source of radiation, distance d will change when the velocity of the electrons changes. Let us show this.

When the light pulses are emitted at intervals of ΔT , and D is the distance between them over the screen, it will be $D = k\Delta T$, where k is the

so-called constant of scanning of the oscillograph and is equal to the horizontal distance which the electronic beam covers over the screen for a unit of time.

Let the velocity of the electrons in the accelerator be first v and then $v + \Delta v$. If the velocity of the source must be added geometrically to the velocity of light, then the velocity of the photons on the track from the accelerator to mirror M will be $c_1 = c + v$ in the first case and $c_2 = c + v + \Delta v$ in the second case.

Hence the time Δt with which the light pulses will come earlier to the receiver in the second case will be (suppose $v, \Delta v \ll c$)

$$\Delta t = \frac{L}{c_1} - \frac{L}{c_2} = \frac{L \Delta v}{(c + v)(c + v + \Delta v)} = \frac{L \Delta v}{c^2}, \quad (36.1)$$

where L is the distance between the accelerator and mirror M .

The difference between the distances d_1 and d_2 in the first and second cases will be $\Delta d = k\Delta t$.

If we choose $\Delta T = 10^{-10}$ s, $L = 9$ m and $\Delta v = c/300 = 10^6$ m/s, we obtain $\Delta t = \Delta T$. Thus for such an increase of the electrons' velocity in the accelerator, the low peaks will be shifted with respect to the high peaks over a distance Δd equal to the distance D between the high peaks.

If the velocity of light does not depend on the velocity of the source, as our absolute space-time theory asserts, then it must be $\Delta d = 0$ for any increase of the electrons' velocity.

REFERENCES

1. Bailey J. *et al.*, 1977, *Nature*, **268**, 301.
2. Bömmel H. E., 1962, *Proceedings of the Second International Conference on the Mössbauer Effect*, Saclay, 1961.
3. Briatore L. and Leschiutta S., 1976, *Lett. Nuovo Cimento*, **15**, 203; **17**, 328.
4. Briscoe J.A., 1958, *British Patent*, London, No. 15089/58 — 884830.
5. Burcev P., 1974, *Phys. Lett.*, **47A**, 365.
6. Carnahan C. W., 1962, *Proc. IRE*, **50**, 1976.
7. Champeney D. C. *et al.*, 1963, *Phys. Lett.*, **7**, 241.
8. Danby J., 1962, *Fundamentals of Celestial Mechanics*, Macmillan Co., New York.
9. Dart H. P., 1971, *Spectr. Lett.*, **4**, 141.
10. Dufour A. and Prunier F., 1942, *J. Phys. et Radium*, **3**, 153.
11. Einstein A., 1905, *Ann. der Phys.*, **17**, 891.
12. Einstein A., 1907, *Jahrbuch der Radioaktivität und Elektronik*, **4**, 411.
13. Einstein A., 1911, *Ann. der Phys.*, **35**, 898.
14. Einstein A., 1914, *Astr. Nachr.*, **199**, 8.
15. Fizeau H., 1851, *Comptes Rendus*, **33**, 349.
16. Godart R., 1974, *Techniques Nouvelles*, **Sept. 1974**, 22.
17. Hafele J. C. and Keating R. E., 1972, *Science*, **177**, 166.
18. Harress F., 1912, *Dissertation*, Jena.
19. Hay H. J. *et al.*, 1960, *Phys. Rev. Lett.*, **4**, 165.
20. Horedt G., 1975, *Czechosl. J. Phys.*, **B25**, 117.
21. Hubble E. P., 1937, *The Observational Approach to Cosmology*, Oxford.
22. Ives H. E. and Stilwell G. R., 1938, *J. Opt. Soc. Am.*, **28**, 215.
23. Jánossy L., 1971, *Theory of Relativity Based on Physical Reality*, Akadémiai Kiadó, Budapest.
24. Jones R. V., 1975, *Proc. Roy. Soc.*, **345**, 351.
25. Karastoyanov A. S., 1972, *Phys. Lett.*, **38A**, 289.
26. Landau L. D. and Lifshitz E. M., 1959, *The Classical Theory of Fields*, Pergamon Press.
27. Landau L. D. and Lifshitz E. M., 1969, *Mechanik*, Vieweg, Braunschweig.
28. Landolt-Börnstein, 1962, *8 Teil — Optische Konstanten*, Springer-Verlag.
29. Larmor J., 1900, *Aether and Matter*, University Press, Cambridge.
30. Lorentz H. A., 1916, *The Theory of Electrons*, Leipzig.

31. Marinov S., 1970, *Phys. Lett.*, **32A**, 183.
32. Marinov S., 1972a, *Phys. Lett.*, **40A**, 73.
33. Marinov S., 1972b, *Phys. Lett.*, **41A**, 433.
34. Marinov S., 1973, *Phys. Lett.*, **44A**, 21.
35. Marinov S., 1974a, *Int. J. Theor. Phys.*, **9**, 139.
36. Marinov S., 1974b, *Czechosl. J. Phys.*, **B24**, 965.
37. Marinov S., 1975a, *Int. J. Theor. Phys.*, **13**, 189.
38. Marinov S., 1975b, *Phys. Lett.*, **54A**, 19.
39. Marinov S., 1976a, *Found. Phys.*, **6**, 571.
40. Marinov S., 1976b, *Int. J. Theor. Phys.*, **15**, 829.
41. Marinov S., 1977a, *Found. Phys.*, **7**, 947.
42. Marinov S., 1977b, *Phys. Lett.*, **62A**, 293.
43. Marinov S., 1978a,
44. Marinov S., 1978b,
45. Marinov S., 1978c, *Gen. Rel. Grav.*, **12**, 57 (1980).
46. Marinov S., 1978d, *Found. Phys.*, **9**, 445 (1979).
47. Marinov S., 1978e, *Found. Phys.*, **8**, 637.
48. Marinov S., 1978f, *Found. Phys.*, **8**, 137.
49. Marinov S., 1978g,
50. Marinov S., 1978h, *Spec. Sc. Techn.*, **1**, 231.
51. Marinov S., 1978i,
52. Marinov S., 1978j, *Ind. J. Theor. Phys.*, **31**, 1 (1983).
53. Marinov S., 1978k, *Found. Phys.*, **11**, 115 (1981).
54. Marinov S., 1978l,
55. Marinov S., 1978m, *Ind. J. Phys.*, **55B**, 403 (1981).
56. Marinov S., 1978n, *J. Phys. A*, **16**, 1885 (1983).
57. Marinov S., 1978o,
58. Marinov S., 1978p, *Ind. J. Theor. Phys.*, **28**, 329 (1980).
59. Marinov S., 1978q,
60. Marinov S., 1978r, *Spec. Sc. Techn.*, **1**, 239.
61. Marinov S., 1978s, *Spec. Sc. Techn.*, **1**, 235.
62. Marinov S., 1978t, *Ind. J. Theor. Phys.*, **31**, 93 (1983).
63. Marinov S., 1978u,
64. Menzel D. H. *et al.*, 1970, *Survey of the Universe*, Prentice-Hall, New Jersey.
65. Michels A. *et al.*, 1947, *Physica*, **13**, 343.
66. Michelson A. and Morley E. W., 1886, *Am. J. Science*, **31**.
67. Player M. A., 1975, *Proc. Roy. Soc.*, **345**, 343.
68. Pogany B., 1928, *Ann. der Phys.*, **85**, 244.
69. Rogers G. L., 1975, *Proc. Roy. Soc.*, **345**, 345.
70. Sagnac G., 1913, *Comptes Rendus*, **157**, 708, 1410.
71. Santos A. N. dos, 1976, *Il Nuovo Cimento*, **32B**, 519.

72. Trouton F. T. and Noble H. R., 1903, *Proc. Roy. Soc.*, **72**, 132.
73. Zeeman P., 1914, *Proc. Roy. Acad. Amsterdam*, **17**, 445.
74. Zeeman P., 1915, *Proc. Roy. Acad. Amsterdam*, **18**, 398.
75. Zeeman P., 1920, *Proc. Roy. Acad. Amsterdam*, **22**, 512.
76. Zeeman P., *et al.*, 1922, *Proc. Roy. Acad. Amsterdam*, **23**, 1402.



Stefan Marinov was born in Sofia on the 1 February 1931 in a family of intellectual communists. In 1948 he finished a Soviet College in Prague and began to study physics at the Universities of Prague and Sofia. In 1951 he went to the Varna High Navy School as a volunteer and after graduating sailed as a deck officer on Bulgarian, Czechoslovak-Chinese and West-German cargoes. In 1958 he came back to Sofia to complete his studies in physics. From 1960 to 1974 he worked as Assistant Professor

in the Physical Faculty of the Sofia University and as scientific researcher in the Physical Institute of the Bulgarian Academy of Sciences, from where he was expelled and pensioned as a paranoic in 1974. From 1974 to 1977 Marinov managed his own Laboratory for Fundamental Physical Problems. In 1966/67, 1974, and 1977 he got compulsory treatment in the Sofia psychiatries because of his political dissent. In September 1977 he received a passport and transferred to Brussels. In 1978 he lived in Washington, where he published his collection of poems LIST OTBRULEN (Heter Peter, Washington, 1978). In 1979—1981 he lived in Genoa, where he published the treaty ECONOMIA POLITICA TEORICA — TEORIA DEI PREZZI (Est Ovest, Genova, 1979). Since 1981 his home is in Graz, where he edited his encyclopaedic CLASSICAL PHYSICS (East West, Graz, 1981) consisting of the following five volumes: 1. Mathematical apparatus. 2. Axiomatics. Low-velocity mechanics. 3. High-velocity mechanics. 4. Gravimagnetism. 5. Electromagnetism. In 1982 he published the first and in 1984 the second part of the collection of documents THE THORNY WAY OF TRUTH (East West, Graz). In July 1982 he organized in Genoa the International Conference on Space-Time Absoluteness (ICSTA) and together with Prof. J. P. Wesley edited the PROCEEDINGS OF ICSTA (East West, Graz, 1982). As a first man in history, in 1973, Marinov succeeded in registering the absolute motion of the Earth in a laboratory with the help of the deviative »coupled mirrors« experiment. His absolute space-time theory elaborated in the last 20 years explains thoroughly all experiments in high-velocity physics. The essence of his theory and description of his experiments are given in EPPUR SI MUOVE.